



Mallard Pass

Solar Farm

Mallard Pass Solar Farm

outline Soil Management Plan (oSMP) [Clean]

Deadline 6 - September 2023

PINS Ref: EN010127

Document Ref: EN010127/APP/7.12.5 (Clean)

Revision P5

Infrastructure Planning (Applications: Prescribed Forms and Procedure) Regulations 2009

Reg 5 (2) (j)

**MALLARD PASS SOLAR FARM,
ESSENDINE**

OUTLINE SOIL MANAGEMENT PLAN

Application Document Ref:

EN010127/APP/7.12.5

Planning Inspectorate Scheme Ref:

EN010127



Table of Contents

1	INTRODUCTION	2
2	SCOPE OF THE oSMP	5
3	SOIL RESOURCES AND CHARACTERISTICS	7
4	KEY PRINCIPLES	10
5	TEMPORARY ACCESS AREAS AND COMPOUNDS	18
6	ACCESS TRACKS AND SOLAR STATIONS.....	21
7	PV ARRAYS	26
8	INSTALLATION OF ON-SITE TRENCHING	32
9	SITE FENCING AND SWALES.....	35
10	SUBSTATION.....	38
11	OPERATIONAL PHASE: LAND MANAGEMENT	42
12	OPERATIONAL PHASE: SOIL STORAGE	46
13	DECOMMISSIONING	47
14	MANAGEMENT AND MONITORING.....	53

Appendices

- A Soil Type Plan
- B Good Practice Guide for Handling Soils in Mineral Workings
- C Agricultural Good Practice Guidance for Solar Farms (2013)
- D Defra Construction Code of Practice for the Sustainable Use of Soils on Construction Sites (extracts only)
- E Outline Excavated materials Management Plan

1 INTRODUCTION

- 1.1 This document provides an outline Soil Management Plan (oSMP) for Mallard Pass Solar Farm (hereafter referred to as ‘the Proposed Development’). A SMP will be produced for the Proposed Development in accordance with a Requirement of the Development Consent Order (DCO) prior to commencing construction, which will be required to be in accordance with this oSMP submitted as part of the DCO Application.
- 1.2 The measures proposed within the oSMP will be agreed upon prior to the commencement of construction and decommissioning works with the relevant local planning authority. The SMP will be prepared following the appointment of a principal construction contractor, prior to the start of works and in accordance with this oSMP.
- 1.3 This oSMP covers the principal construction, operation and decommissioning activities envisaged at the time of preparing the **Environmental Statement (ES) [EN010127/APP/6.1]**. This oSMP is intended to be a live document, such that modifications and necessary interventions can be made as construction and decommissioning is carried out.
- 1.4 The appointed construction contractor will be responsible for working in accordance with the environmental controls documented in this oSMP, pursuant to the DCO. The overall responsibility for implementation of the SMP will lie with the appointed contractor as a contractual responsibility to the Applicant, as the Applicant is ultimately responsible for compliance with the Requirements of the DCO. A suitably-experienced soil specialist will be engaged to advise on soil handling, including advising on when soils are sufficiently dry to be handled, as required.
- 1.5 The Order limits are shown on Figure 1 and described in **Chapter 3: Description of Order Limits** of the ES. They comprise the Solar PV Site, Mitigation and Enhancement Areas, Highway Works Site and the Grid Connection Corridor.
- 1.6 The Proposed Development and construction activities are described in **Chapter 5: Project Description** of the ES.

- 1.7 Large areas within the Order limits do not involve any movement or trafficking (being passed over by vehicles) of agricultural land and soils, and will remain in agricultural use. Whilst this oSMP, therefore, focuses mostly on the areas required temporarily during construction, the access tracks and areas associated with the Solar Stations, the PV Arrays, onsite trenching and site fencing, it also covers the retained arable fields within the mitigation and enhancement areas.
- 1.8 An outline Excavation Material Management Plan (oEMMP) has been prepared in support of this oSMP. The oEMMP sets out how excavation waste will be handled. EMMPs (based on the oEMMP) will be prepared alongside the SMPs, both of which will be produced for each phase (or more than one phase) of the Proposed Development pursuant to a Requirement of the Development Consent Order (DCO) prior to commencing construction and decommissioning.

Purpose of this document

- 1.9 The objective of the oSMP is to identify the importance and sensitivity of the soil resource and to provide specific guidance to ensure that there is no significant adverse effect on the soil resource as a result of the Proposed Development.
- 1.10 The oSMP is structured as follows:
- (i) section 2 sets out the scope of the oSMP;
 - (ii) section 3 describes the soil resources and characteristics;
 - (iii) section 4 sets out key principles;
 - (iv) sections 5-9 set out the soil management requirements for key aspects of the Proposed Development:
 - section 5: temporary access areas and compounds;
 - section 6: access tracks and Solar Stations;
 - section 7: the PV Arrays;
 - section 8: onsite trenching;
 - section 9: site fencing and swales;
 - section 10: substation;
 - (v) sections 11 to 12 cover the operational phase:
 - section 11: the Solar PV Site and mitigation and enhancement areas;
 - section 12: soil storage;

- (vi) section 13 sets out an outline of the decommissioning phase;
- (vii) section 14 sets out monitoring and aftercare.

- 1.11 This oSMP draws on professional experience with the installation of solar panels. It also draws on experience with the installation of underground services (especially pipelines), and with soil movement and restoration of agricultural land in connection with roads, quarries and golf courses.
- 1.12 This document has been updated to take account of comments made by Natural England and other consultees at Deadline 2 and in stakeholder meetings.

2 SCOPE OF THE oSMP

- 2.1 This oSMP covers the construction and decommissioning phases of the Proposed Development. Operational activities such as the management of soil bunds are covered by the ***outline Operational Environmental Management Plan (oOEMP)***. There is no requirement for an oSMP for the operational phase, as there should be no requirement to disturb or move soils. However the management of soil bunds is included in the oSMP and the detailed OEMP(s) must include those measures.
- 2.2 For the majority of the Order limits there will be no movement of soils. This oSMP sets out:
- a description of the soil types and their resilience to being trafficked;
 - construction compounds and short-term construction soil handling;
 - an outline description of proposed access routes and details of how access will be managed to minimise impacts on soils;
 - a description of works and how soil damage will be minimised and ameliorated; and
 - a methodology for monitoring soil condition, and criteria against which compliance will be assessed.
- 2.3 The installation of the Mounting Structures, and the assembly of the PV Tables, does not require the movement or disturbance of soils. Those works should not, therefore, result in localised disturbance or effects on soils or agricultural land quality. The oSMP covers vehicle movements, trenching, foundations and related impacts.
- 2.4 Trenching works to connect the PV Tables to the Solar Stations and Onsite Substation do have the potential to cause localised effects on soils. Whilst such works will not result in adverse effects on the agricultural land classification, localised damage will be minimised by good practice. This oSMP sets out soil resilience, best practice and monitoring criteria.
- 2.5 In localised areas there is a need for access tracks or bases for infrastructure and equipment within the Solar Stations. In those localised areas soil will need to be stripped and moved, for stockpiling for subsequent restoration. This oSMP sets out:

- a description of the soil types and their resilience to being stripped and handled;
- a methodology for creating and managing stockpiles of soil;
- an outline methodology for testing soils prior to restoration, and a methodology for respreading and ameliorating compaction at restoration.

2.6 This oSMP focuses on the construction phase and immediate aftercare and the decommissioning phase. It covers the operational phase, during which there should be no requirement to disturb or move soils.

2.7 This oSMP covers the retained arable fields within the mitigation and enhancement areas but there will be no stripping or movement of soils. The **outline Construction Environmental Management Plan (oCEMP)** includes a control measure to control trafficking within these areas. Where there is an internal access track within the mitigation and enhancement areas, vehicle movements will be restricted to the access tracks.

3 SOIL RESOURCES AND CHARACTERISTICS

Climatic Conditions

- 3.1 The climatic data for the area, using the climate data set for Agricultural Land Classification (ALC), shows annual rainfall between 575 and 590mm across the Order limits.
- 3.2 Soils are at field capacity, ie replete with water, for usually 104 - 111 days per year, from autumn to early spring. This is the period when soils are most susceptible to damage because they are saturated.

Agricultural Land Quality

- 3.3 Soil surveys and ALC surveys (part detailed, part semi-detailed) have been carried out across the area within the Order limits (see **Chapter 12: Land Use and Soil** of the ES. No survey has been carried out of the Grid Connection Corridor, which is part of National Grid's land and is not in agricultural use.
- 3.4 The results of the ALC survey are set out in an **Appendix 12.4: ALC Survey** of the ES Appendices [EN010127/APP/6.2] and shown in **Figure 12.1** of the ES Figures [EN010127/APP/6.3].

Extent and Depth of Topsoil Units and Soil Types

- 3.5 As set out in the ALC, the soils within the Order limits are predominantly developed over limestone of a number of different geological types and are quite variable spatially over short distances, e.g. due to variations in soil depth to impenetrable rock, stone/rock content and wetness class. This leads to a quite complex pattern of ALC Grade 2, Subgrade 3a, Subgrade 3b and Grade 4. This is due to a combination of factors, particularly soil droughtiness and topsoil stone content on Elmton and Sherborne soils over limestone, and soil wetness on wetter and heavier (clayey) Denchworth soils over mudstone and Fladbury soils developed in river alluvium.
- 3.6 For ease of assessment, the soil survey divided the Order limits into eleven parcels as shown on the plan below. This is derived from the soil information and properties assessed as part of the ALC and soil survey, including auger and pit evaluation.

Insert 1: Survey Areas Identified

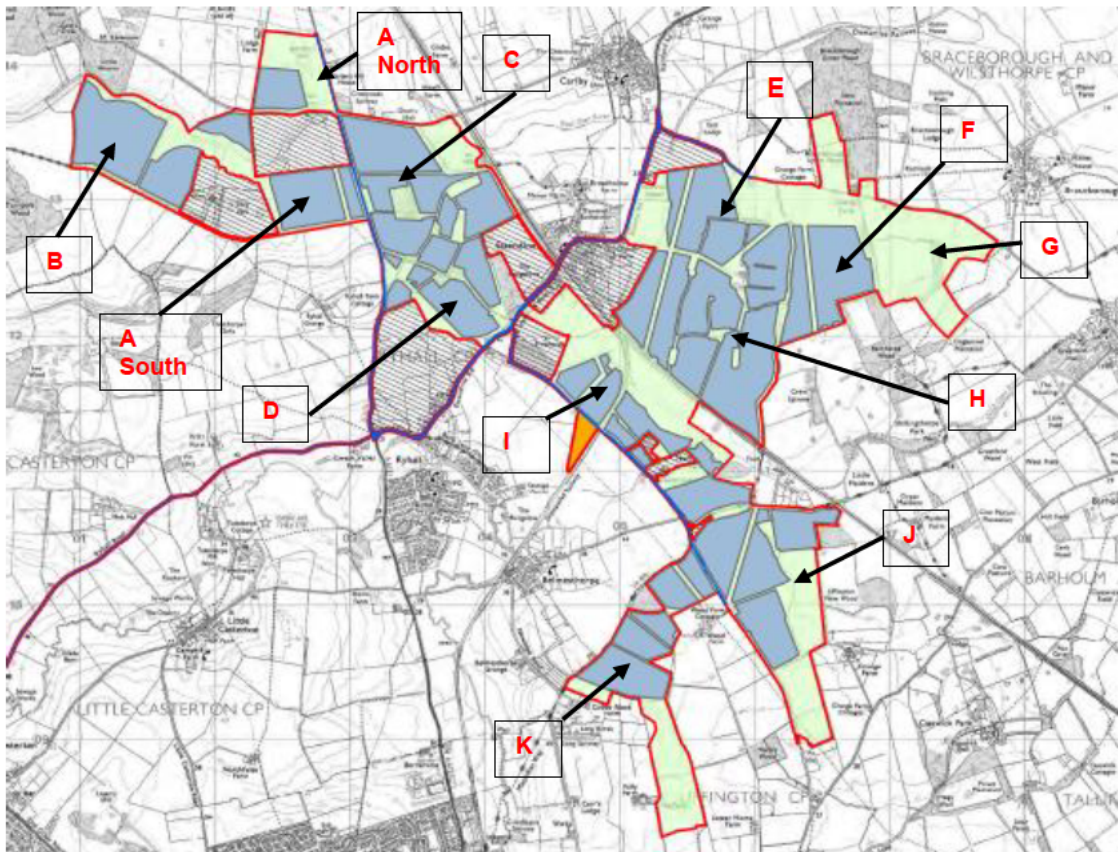

3.7 The predominant soils for the topsoil and upper subsoil in each area are recorded in the table below.

Table 1: Predominant Soil Type

Area	Topsoil		Upper Subsoil	
	Depth (cm)	Predominant Texture	Depth (cm)	Predominant Texture
A (North)	0-35	HCL/C	35-60 (occ deeper)	C
A (South)	0-35	MCL and HCL	35-60	MCL/HCL/C
B	0-35	MCL and HCL	35-60+	MCL/HCL/occ C
C	0-35	MCL/HCL, C to the south	35-50+	C
D	0-25	HCL/C	25-50	C,
E	0-30	MCL/HCL/C	30-50+	C, occ SLC
F	0-30	MCL/C	30-60	HCL/C
G	0-30	MCL/HCL	30-60	MCL/HCL/C
H	0-25/30 (variable)	MCL/HCL/C	25-50+	HCL/C
I	0-25	C	25-50+	C
J	0-25	HCL/C	25-50+	C
K	0-30	C	25-50	C

C - Clay

HCL - Heavy clay loam

MCL - Medium clay loam

SCL - Sandy clay loam

- 3.8 The areas of principally medium clay soils, and the areas of principally heavy clay soils, are mapped in **Appendix A**.
- 3.9 Propensity to Damage The Institute of Environmental Management and Assessment (IEMA) have produced a Guide “A New Perspective on Land and Soil in Environmental Impact Assessment” (2022). Table 4 in the guidance identifies that clay and heavy clay loam soils where the Field Capacity Days (FCD) is less than 150 (as here) have a medium resilience to structural damage.
- 3.10 The IEMA guide identifies that lighter soils, including medium clay loams, are of medium resilience where the FCD is less than 225. Here, where the FCD is 104 - 111 days, these medium resilience soils will be at a low risk of structural damage for much of the year.

4 KEY PRINCIPLES

Overview

- 4.1 For much of the installation process there is no requirement to move or disturb soils. Soils will need to be disturbed to enable cables to be laid, but the soils will be reinserted shortly after they are lifted out (I.e. this is a swift process).
- 4.2 Soils will need to be moved and disturbed to create temporary working compounds, and to create the access tracks and small fixed infrastructure bases within the Solar Stations. The effects on agricultural land quality and soil structure may also arise from vehicle passage. This is agricultural land, so it is already subject to regular vehicle passage. Therefore, the key consideration is to ensure that soils are passed over by vehicles (trafficked) when the soils are in a suitable condition, and that if any localised damage or compaction occurs (which is common with normal farming operations too), it is ameliorated suitably.
- 4.3 Soil handling, movement and trafficking will be undertaken under the supervision of an appropriately experienced soil specialist to advise on and supervise soil handling, including identifying when soils are dry enough to be handled.
- 4.4 The key principles for successfully avoiding damage to soils are:
- timing;
 - retaining soil profiles;
 - avoiding compaction;
 - ameliorating compaction; and
 - storing soils for subsequent reuse.

Timing

- 4.5 The most important management decision/action to avoid adverse effects on soils is the timing of works. If the construction work takes place when soil conditions are dry, then damage from vehicle trafficking and trenching will be minimal.
- 4.6 The soils are relatively resilient to vehicle passage for much of the year. Under the ALC the field capacity period, ie the days in the year when soils are

saturated, is about 104 to 111 days per year. This is normally between the beginning of November and the end of February.

- 4.7 Where it can be achieved, advanced sowing with grass is advantageous for construction purposes. However, in some areas that will not provide the best outcome, and a successful sward may be better achieved by sowing following installation and when trenching has been completed. As much advance-sowing of the Site as possible will be carried out. This will not be possible in all areas and the decision over which areas to sow will be a local decision, to be taken closer to the start of works. The decision will be influenced by the expected timing of construction works, the weather, the time of the year and the date when previous agricultural crops are harvested.
- 4.8 Between those times there is an increased risk of creating localised damage to soil structure from vehicle passage. There are obviously a great number of variables, such as recent rainfall pattern, whether the ground is frozen or has standing water, inevitable variations in soil condition across single fields, and the size and type of machinery driving onto the land.
- 4.9 The general objective should be that construction activities requiring vehicles to travel across open fields should be limited between November and the end of February, or outside of that period if the ground conditions are clearly not suitable and vehicles are causing ruts.
- 4.10 Similarly as a general rule any activity that requires soil to be dug up and moved, such as cabling works, should be avoided during that period too. Soils handled when wet tend to lose some of their structure, and this results in them taking longer to recover after movement, and potentially needing restorative works (eg ripping with tines) to speed recovery of damaged soil structure.
- 4.11 Soils that are too wet can usually be rolled into a sausage shape, such as shown below, or become rutted when trafficked, as shown in the photographs below. If water is sitting in the tramlines or standing on the surface of the land the soils will likely be too wet for handling. These soils often stick to boots when crossing arable land.

Photos 1 to 3: Soil When too Wet for Handling



- 4.12 Areas of medium clay loam are likely to be suitable for trafficking earlier than areas of heavy clay loam.

Supervision and Management

- 4.13 A suitably qualified and experienced soil surveyor will be engaged in the spring, prior to works commencing (whether for construction or decommissioning), to inspect the soils across the relevant parts of the Site (medium clay loam areas)

to advise whether and when soils are suitable for construction activities to begin. The soils surveyor must be a soil scientist who is a Professional Member of the British Society of Soil Science (BSSS) and will report to the Environment Manager and Site Manager, as defined in the oCEMP.

- 4.14 The soil surveyor will similarly be advised to review soils and inform when construction activities need to be curtailed in the autumn due to unsuitable ground conditions.
- 4.15 Site operatives will also be advised about the "field tests for suitably dry soils" set out in the Institute of Quarrying "Good Practice Guide for Handling Soils in Mineral Workings" (2022), an extract from which is reproduced in **Appendix B**. This advises on a consistency test for determining whether soil is suitable for being handled in Table 4.2.

Localised Areas

- 4.16 In localised instances where it is not possible to avoid undertaking construction activities when soils are wet and topsoil damage occurs then soils can be recovered by normal agricultural management, using normal agricultural cultivation equipment (subsoiler, harrows, power harrows etc) once soils have dried adequately for this to take place. There may be localised wet areas in otherwise dry fields, for example, which are difficult to avoid.

Retaining Soil Profiles

- 4.17 The successful installation of cabling at depths of up to 130cm requires a trench to be dug into the ground. Topsoils vary across the Order limits but the coverage is generally 30cm, with subsoils below that being generally similar to depth. As set out in the BRE Agricultural Good Practice Guidance for Solar Farms (extract at **Appendix C**) at page 3:

“When excavating cable trenches, storing and replacing topsoil and subsoil separately and in the right order is important to avoid long-term unsightly impacts on soil and vegetation structure. Good practice at this stage will yield longer-term benefits in terms of productivity and optimal grazing conditions”.

- 4.18 In those areas where the soil is dug up (trenching and for compounds and access tracks), the soils should be returned in as close to the same order, and in similar profiles, as it was removed.

Avoiding Compaction

- 4.19 This oSMP sets out when soils should generally be suitable for being trafficked. There may be periods within this window, however, when periodic rainfall events result in soils becoming liable to damage from being trafficked or worked. In these (likely rare) situations, work should stop until soils have dried, usually within 48 hours of heavy rain stopping. The examination and consistency tests set out in **Appendix B** should be used to inform the decision taking process. If there is concern, the advice of the appointed soil surveyor should be sought.
- 4.20 Areas of the Order limits which are not to be stripped or used for stockpiling, locations of re-instated soil, access tracks or construction compounds, will be clearly marked by signs and barrier tape to avoid trafficking.

Ameliorating Compaction

- 4.21 If localised compaction occurs during construction, it should be ameliorated. This can normally be achieved with standard agricultural cultivation equipment, such as subsoilers (if required), power harrows and rolls.
- 4.22 The amount of restorative work will vary depending upon the localised impact. Consequently, where the surface has become muddy, for example in the photograph below, this can be recovered once the soil has dried, with a tine harrow and, as needed, a roller or crumbler bar.

Inserts 2 and 3: Inter-row Ground Restoration





4.23 The type of machinery involved is shown below. This shows farming and horticultural versions.

Inserts 4 – 7: Type of Machinery Involved



- 4.24 If there are any areas within the Order limits where there has been localised damage to the soils due to vehicle passage, for example, a low wet area within a field which despite best efforts could not be avoided, this should be made good and reseeded at the end of the installation stage. This is not uncommon: most farmers will have times when they have to travel around the farm in a tractor in conditions where the tyres make deep impacts. This can happen during harvest time, for example, especially of late crops or in very wet harvest seasons. Whilst this is avoided so far as possible, it occurs and the effects are made good when conditions are suitable.
- 4.25 With these soils, including the slowly permeable clayey soils, these areas will readily restore. The ruts need to be harrowed level when the ground is dry, and then they will naturally restore.
- 4.26 Accordingly the ground surface should be generally levelled prior to any seeding or reseeded.
- 4.27 Soil pits should be excavated following alleviation to confirm the compaction has been successfully restored.

Storing Soil and Restoring Soil

- 4.28 Soil removed from an area should, so far as possible, be replaced in the same area. This will minimise the potential for soil variability, which can affect the way fields (especially arable fields) are farmed. Therefore, soil storage should either be close to where the soil will be restored, or otherwise well labelled and recorded so that the soil can be replaced as close as possible to where it originated from.
- 4.29 The quantities of soil involved are limited and topsoil mounds would be a maximum of 1.5m high. This will not result in the soil becoming anaerobic even in storage in a mound for 25 years. Advice on the stockpiling of soils taken from the Construction Code of Practice for the Sustainable Use of Soils on Construction Sites (Defra, 2009) is reproduced in **Appendix D**. These areas (bunds) will need to be sown to a grassland mix if being stored for in excess of six months, to help soil structure and to bind the soils and prevent erosion. The grassed bunds will need to be managed at least annually during the life of the

Proposed Development to prevent the establishment of woody growth or brambles, in accordance with the **oOEMP** and **oLEMP**.

- 4.30 The proposed stockpile locations, volumes and soil type(s) will be set out in the SMP (s) prepared at detailed design of the Proposed Development. Stockpiled soils will be labelled and protected from trafficking. Any soil stockpiles in place for more than 6 months will be seeded.
- 4.31 Temporary soil heaps will be stored at least 10 metres from watercourses to avoid the risk of sediment pollution.
- 4.32 Soil will only be stored in designated locations to avoid compaction by trafficking.
- 4.33 The restoration will ensure that soil is returned as close as possible to the area from where it came, and to the same profile as the land adjacent to the restored area. This will result in the soil profile and land quality being returned to the comparable quality and properties of the adjacent land.
- 4.34 The restoration methodology will reinstate the land quality to the same land quality as the land immediately next to the area affected, as measured by the ALC Revised Guidelines and Criteria (1988) or by any subsequent ALC methodology in force at decommissioning.
- 4.35 The quality of the soil reinstatement will be verified by a competent soil surveyor. Post-restoration surveys will be undertaken across all land reinstated to determine whether target soil profile specifications have been met. A programme of aftercare will be undertaken to ensure the soil characteristics achieve the restoration standard.

5 TEMPORARY ACCESS AREAS AND COMPOUNDS

Advice

- 5.1 Advice on assessing soil suitability is set out in IQ notes in Table 4.2 at **Appendix B**.
- 5.2 Advice on moving and handling soils is set out below and in the Defra Code of Practice extracts at **Appendix D**.
- 5.3 Prior to soil stripping in construction areas the suitability of the soil for being handled will be considered. If this is to take place early in the spring, the advice of the retained soil surveyor will be sought as appropriate, and that advice will be followed.

Construction Methodology

- 5.4 These areas are intended for short-term construction activity only.
- 5.5 The full depth of topsoil should be stripped by machinery and stored in a low mound alongside the track or working yard area. Then a membrane is laid down. Onto this is placed a mix of as-dug stone topped, if needed, with smaller stone which is spread and rolled level. At the end of the construction, the stone is dug up and removed, the membrane removed, the area is loosened by a subsoiler or plough, and the topsoil spread back over before being harrowed with standard agricultural machinery. It can then be reseeded.

Soil Management

- 5.6 Construction will commence when soils are suitably dry to be moved without smearing. This will normally be between the beginning of March and the end of October for the medium clay areas, and from mid-March to late October for the clayey areas, see **Appendix A**.
- 5.7 Prior to the commencement of stripping soils any tall vegetation shall be removed.
- 5.8 Within areas of any temporary works, including any construction compounds or access tracks if required, the topsoil will be stripped and stockpiled to the side of the area ready for restoration (likely to be a matter of months later). An example of a temporary bund is shown in the photograph below.

Insert 8: Short-term Topsoil Storage Bund



- 5.9 The area will then be covered with suitable permeable matting to prevent stones from mixing with the soil. Stone will then be laid on the matting to create the temporary working area.
- 5.10 It is important that these areas are restored when both the topsoil (in bunds and any remaining on the site) and upper subsoils, are suitably dry to be trafficked. Therefore prior to restoration the retained soil surveyor should advise on the timing. It may be that areas will be left for restoration in the following year if conditions are not, or are not expected to be, suitable for the duration of the restoration period. The restoration requires first that the stone and matting are removed. That will leave an area, for example as shown below. This area will be loosened prior to topsoil being spread back over the site.

Insert 9: Example of Area Prior to Topsoil Placement



- 5.11 The advice of the retained soil surveyor, and the general advice from Defra's Construction Code of Practice set out in **Appendix D**, at section 6 should be followed.

5.12 Subject to the above advice, typically the area will then be harrowed with standard agricultural spring-tine harrows or a power harrow, to loosen the topsoil and level the area. The area can then be sown to grass.

6 ACCESS TRACKS AND SOLAR STATIONS

Advice

- 6.1 Advice on assessing soil suitability is set out in IQ notes in Table 4.2 at **Appendix B**.
- 6.2 Advice on moving and handling soils is set out below and in the Defra Code of Practice extracts at **Appendix D**.
- 6.3 Prior to soil stripping in construction areas the suitability of the soil for being handled will be considered. If this is to take place early in the spring, the advice of the retained soil surveyor will be sought as appropriate, and that advice will be followed.

Construction Methodology

- 6.4 Prior to constructing tracks any tall vegetation will be removed. The access tracks are then created by stripping off some or all of the topsoil and then adding an aggregate-based surface. Usually, the aggregate will be placed onto a permeable membrane, which allows water penetration but which prevents the aggregate from mixing with the topsoils or upper subsoils.
- 6.5 The topsoil will be stored in mounds up to 1.5m high, as described below. A typical mound is shown below, with a maximum height limit to ensure that soils in the centre remain aerobic. Where storage is to be long-term (six months or more) these mounds should be seeded with a suitable grass seed mix.

Insert 10: Typical Soil Mound





- 6.6 This soil is therefore kept in a suitable condition for reinstatement once the access track has been removed at the end of the development, as described below. Extracts from the Defra Construction Code of Practice are set out in **Appendix D.**
- 6.7 The equipment within the Solar Stations normally stand on concrete bases. As these areas will be restored in the future, the construction is carried out in accordance with the Defra Construction Code of Practice for the Sustainable Use of Soils on Construction Sites as follows:
- (i) tall vegetation / crops should be cleared prior to topsoil stripping.
 - (ii) Depending upon the depth required for the base, the full depth of topsoil will be removed. In some cases a lesser depth of removal will be appropriate. This will be stored in a mound no more than 1.5m high at an agreed location, for use in future restoration;
 - (iii) the base of stone is then added, and forming put around before concrete is poured to create the pad;
 - (iv) the equipment is then placed on top;
 - (v) further security fencing is added once the cabling and connections are complete.
- 6.8 There may be alternative fixings in some locations, for example where legs are pile driven. They will create no greater damage, and may be possible without the need to move soils.
- 6.9 The inverters and other heavy equipment is delivered to the Order limits and taken to the concrete pad areas by low-ground-pressure agricultural equipment, such as that shown below (courtesy of BSR), or along the access tracks.

Insert 11: Low Ground Pressure Agricultural Equipment



Case Steiger Quadtrac used to deliver inverters and other heavy equipment to site under soft ground conditions (photo courtesy of British Solar Renewables)

Soil Management

- 6.10 Soil should be stripped in layers when the soil is sufficiently dry and does not smear. This is a judgement that is easily made. If the soils can be rolled into a sausage shape in the hand which is not crumbly, or if rubbing a thumb across the surface causes a smudged smooth surface (a smear), the soil is too wet to strip or move. Topsoil depths vary but a stripping depth of 30cm will be a suitable maximum depth for topsoil in most cases, although rarely will it need to be stripped to such a depth.
- 6.11 Soil stripping should be carried out in accordance with Defra “Construction Code of Practice for the Sustainable Use of Soils on Construction Sites” (Defra, 2009).
- 6.12 The removed soil should be stored in mounds in accordance with the Construction Code of Practice. The SMP will need to identify the location and profiling for the mounds. Mound heights of circa 1.5m maximum will normally be suitable. These mounds need to be recorded and labelled appropriately so that the soils can be returned as close as possible to the areas from where they were removed, at the restoration stages.
- 6.13 In the unlikely event that excavation below topsoil depth is required, then subsoils should be stored in separate mounds to topsoils.

- 6.14 These areas need to be managed at least annually to prevent the growth of woody vegetation, such as brambles or shrubs, in accordance with the **oOEMP** and **oLEMP**.
- 6.15 Advice on management of the soil bunds is also provided in section 12.

Restoration

- 6.16 It is important to restore soils when conditions are suitable. At the current time this work should not start until soils have dried, typically by May, but with climate change the advice of a suitable qualified soil surveyor should be taken prior to decommissioning.
- 6.17 The concrete bases within the Solar Stations will need to be broken up. This will most likely involve breaking with a pneumatic drill or back-actor bucket to crack the concrete, after which it can be dug up and loaded onto trailers and removed.
- 6.18 The ground beneath the base may then benefit from being subsoiled, to break any compaction. This can be done by standard tractor-mounted equipment, such as the following examples.

Inserts 12 and 13: Tractor Mounted Equipment



- 6.19 About 4 weeks before restoration takes place the mounds should be strimmed (in accordance with the **oDEMP** which requires ECoW supervision) and any grass and weed growth removed, and the remaining vegetation should be killed off.
- 6.20 The soil can then be spread over the subsoiled base, and made good with standard spring-tine harrow or power harrow machinery.

7 PV ARRAYS

Advice

- 7.1 As described below the installation of the PV Arrays does not require many passes with machinery. Nevertheless it is important that these occur when soil is suitably dry so that there will not be consequential compaction.
- 7.2 Advice on assessing soil suitability to be trafficked is set out in the IQ notes in Table 4.2 at **Appendix B**.

Construction Methodology

- 7.3 The process involves the following stages:
- (i) marking-out and laying out of the framework of the Mounting Structures. For this a vehicle needs to drive across the field possibly with a trailer, from which the legs are off-loaded by hand, or by use of a Bobcat such as that shown below delivering legs;

Insert 14: Bobcat Delivering Legs



- (ii) pile driving in the legs. This involves a pile driver, knocking the legs down to a maximum 2.5m. The machinery is shown in the inserts below.

Inserts 15 – 17: Pile Driving in the Legs



(iii) the Mounting Structure is then constructed. The frame of the Mounting Structure is brought onsite, bolted together, and the PV Modules bolted on, as per the series of photographs below.

Inserts 18 - 20: Constructing the Mounting Structure



- 7.4 The Mounting Structure upon which the PV Modules will be mounted will be pile driven or screw mounted into the ground to a maximum depth of 2.5m, subject to ground conditions. The option to install concrete blocks known as "shoes" may also be considered, avoiding the need for driven and screw anchored installation, therefore minimising ground disturbance. Provided that the ground conditions are suitable (ie the soil is not so wet that vehicles cause tyre marks, such as shown below, deeper than about 10cm when travelling across the land), these construction activities will not result in any structural damage or compaction of soils.

Inserts 21 and 22: Ground After Construction When Ground Conditions are Suitable



Soil Management

- 7.5 Distribution of PV Modules can commence, assuming that soil conditions are suitable (ie the soil is not so wet that vehicles cause tyre marks, such as shown below, deeper than about 10cm when travelling across the land).

Insert 23: Track Marks Showing Ground When Conditions Are Not Suitable



- 7.6 In most years work can start from the beginning of March in the medium clay areas, and from a week or two later (ie mid-March) in the clay areas. See **Appendix A**. Distribution of PV Modules can then continue until the end of October in most years.
- 7.7 Occasionally in this country we experience prolonged rainfall in the summer months that saturate soils. If following a rainfall incident distribution is causing rutting deeper than 10cm, activity should stop to allow soils to dry. The delay can only be judged on an individual basis, because there are so many variables.
- 7.8 It is very unlikely that trafficking during construction will result in compaction sufficient to require amelioration. However, if rutting has resulted the soil should be levelled by standard agricultural cultivation equipment such as tine harrows, once the conditions suit, and prior to seeding. This can be done with standard

agricultural machinery, or with small horticultural-grade machinery such as is shown below.

Inserts 24 and 25: Horticultural Machinery



- 7.9 The objective is to get the surface to a level tilth for seeding/reseeding as necessary, as was shown earlier.

Inserts 26 and 27: Inter-row Ground Restoration



- 7.10 As noted earlier, wherever feasible the land will have been sown to grassland before the installation process starts. In areas where grassland has been established, if there is localised disturbance (for example wet patches in fields), and there is a need to alleviate compaction or level the surface, this will be carried out in the same way as described above.
- 7.11 It may be that these areas will require some additional seeding following this work. That will be carried out at the appropriate time as soon as possible after the levelling works have been completed, most probably being the early autumn following the restoration works, once the ground has (or is due to receive) rainfall to aid seed germination.
- 7.12 Any bare patches identified the following spring will be reseeded, most probably by hand as the areas will be small.

8 INSTALLATION OF ON-SITE TRENCHING

Advice

- 8.1 Advice on assessing soil suitability is set out in IQ notes in Table 4.2 at **Appendix B**.
- 8.2 Advice on moving and handling soils is set out below and in the Defra Code of Practice extracts at **Appendix D**.
- 8.3 Prior to any trenching the suitability of the soil for being moved will be considered. If this is to take place early in the spring, the advice of the retained soil surveyor will be sought as appropriate, and that advice will be followed.

Construction Methodology

- 8.4 Cabling is done mostly with either a mini digger or a trenching machine. Trenches will mostly be at depths of 0.8 – 0.9m and can be up to 1.3m, where soil depth permits, although the CCTV trenching around the periphery could be shallower. An example trench, with the topsoil, placed on one side (0-30cm) and subsoil on the other (below 30cm), is shown below, and with the soil put back after cable installation.

Inserts 28 and 29: Cable Installation



- 8.5 The type of machinery used for trenching is shown below, taken from the BRE National Solar Centre “Agricultural Good Practice Guidance for Solar Farms” (2013) (this is reproduced as **Appendix D**).

Insert 30: Machinery Used



Cable trenching, showing topsoil stripped and set to one side, with subsoil placed on the other side ready for reinstatement (photo courtesy of British Solar Renewables)

- 8.6 The trenches are narrow (a maximum of 1m), and in most cases, it is not considered likely that any grass seed will be needed. The grass in the topsoil will recover rapidly as the following photograph (Insert 31), taken 4 weeks after the trenches were back-filled, shows.

Insert 31: Grass After 4 Weeks



(These photos were taken on heavy, clay soils with poorly draining subsoil, and the work was photographed in July and August 2015)

Soil Management

- 8.7 All trenching work will be carried out when the topsoil is dry and not plastic (ie it can be moulded into shapes in the hand).
- 8.8 The top 30cm will be dug off and placed on one side of the trench, for subsequent restoration. There is no need to strip the grass first.

- 8.9 The subsoils will then be dug out and placed on the other side of the trench, as per the example below.

Insert 32: Subsoils Dug out of the Trench



- 8.10 Once the cable has been laid, the subsoils will be placed back in the trench. Where there is a clear colour difference within the subsoils, so far as practicable the lower subsoil will be put back first and the upper subsoil above that, which is likely to happen anyway as the lower soil is at the top of the pile.
- 8.11 The subsoils will be pressed down by the bucket to speed settlement.
- 8.12 The topsoil will then be returned onto the top of the trench. It is likely, and right, that the topsoil will sit 5-10cm higher than the surrounding level. This should be left to allow it to settle naturally as the soils become wetter.
- 8.13 If there is a surplus of topsoil this may be because the lower subsoils were dry and blocky and there are considerable gaps in the soil. These will naturally restore once the lower soils become wet again. If the trench backfilling will result in the soil being more than 5-10cm proud of surrounding levels, which is unlikely but possible, the topsoil should not be piled higher. It should be left to the side, and the digger would return once the trench has settled and add the rest of the topsoil onto the trench at that point.
- 8.14 Any excess topsoil should not be piled higher than 5 – 10cm above ground level.
- 8.15 A suitable grass seed mix should be spread by hand over any parts of the trenches in accordance with the **oLEMP**.

9 SITE FENCING AND SWALES

SITE FENCING

Advice

- 9.1 Site fencing involves a tractor mounted post knocker, and quads and 4WD vehicle. Posts are most easily knocked in when soils are sufficiently moist, rather than dry, but similar considerations will be taken to avoid installing fences when the ground is not suitable for being driven across.

Construction Methodology

- 9.2 Fence is likely to be a 'deer fence' (wooden posts and metal wire mesh) and will be up to 2m in height. Pole mounted internal facing closed circuit television (CCTV) systems installed at a height of up to 3.5m are also likely to be deployed around the perimeter of the PV Arrays. Access gates will be of similar construction and height as the perimeter fencing.
- 9.3 This can be erected at any time, if soil conditions allow. The following photographs show the fencing installed early in the process.

Inserts 33 and 34: The Fencing



- 9.4 Similarly CCTV poles are inserted in the same way.

Insert 35: CCTV Pole and Fencing



Soil Management

- 9.5 If the movement of vehicles is not causing significant rutting (ie more than 10cm), then fencing could be erected outside of the key working period.
- 9.6 Any rutting that results from fencing can be made good with standard agricultural equipment.

SWALES AND SCRAPES

- 9.7 There may be a need for localised and small scrapes/swales to collect water run-off. These will involve removing the topsoil and creating a shallow ditch. Examples are shown below.

Insert 36 and 37: Examples of swales



- 9.8 These areas are usually grassed and form part of the grazed or management areas.
- 9.9 A critical part of successful restoration at the end is to have stored the soils for replacement.
- 9.10 In the first example above soils were simply placed in a shallow bund on the downhill side of the scrape, and at restoration that soil will be pushed back with a bucket on the front of a tractor, or if the land is ploughed and cultivated the soils will spread into the scrape within a pass or two of the cultivators.
- 9.11 In the second example the soils were removed and placed into a long-term soil storage bund, for return at decommissioning.
- 9.12 The soil will be stored by one or other of these methods, and therefore complete restoration on decommissioning will be achieved.
- 9.13 The general principles set out in section 4 will be applied. All soil movement will take place when the soils are suitably dry.

10 SUBSTATION

Advice

- 10.1 Advice on assessing soil suitability is set out in the IQ notes in Table 4.2 at **Appendix B**.
- 10.2 Advice on moving and handling soils is set out below and in the Defra Code of Practice extracts at **Appendix D**.
- 10.3 Prior to soil stripping in construction areas the suitability of the soil for being handled will be considered. If this is to take place early in the spring, the advice of the retained soil surveyor will be sought as appropriate and that advice will be followed.

Proposals

- 10.4 The substation proposals are shown below.

Insert 38: Proposals in Context

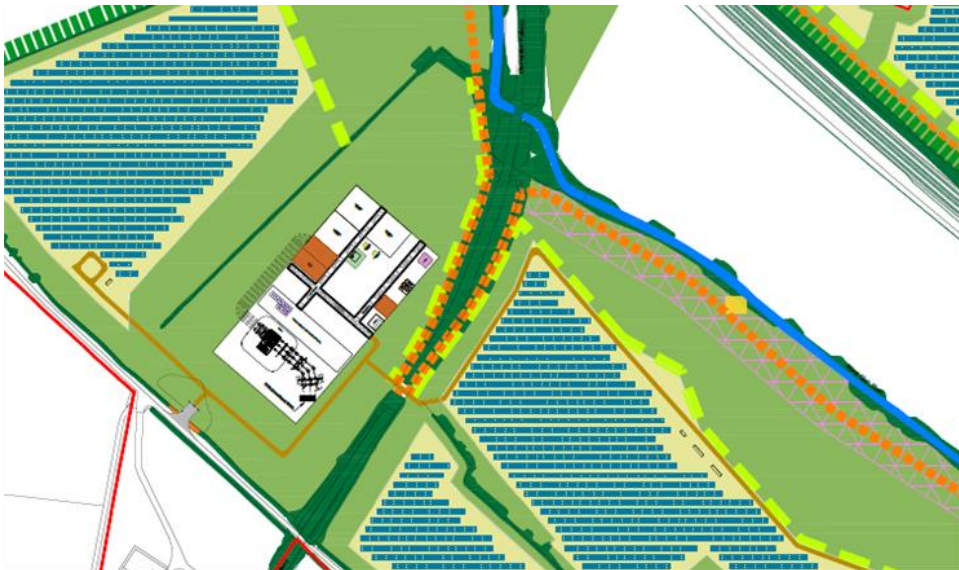

Insert 39: Indicative Onsite Substation Layout

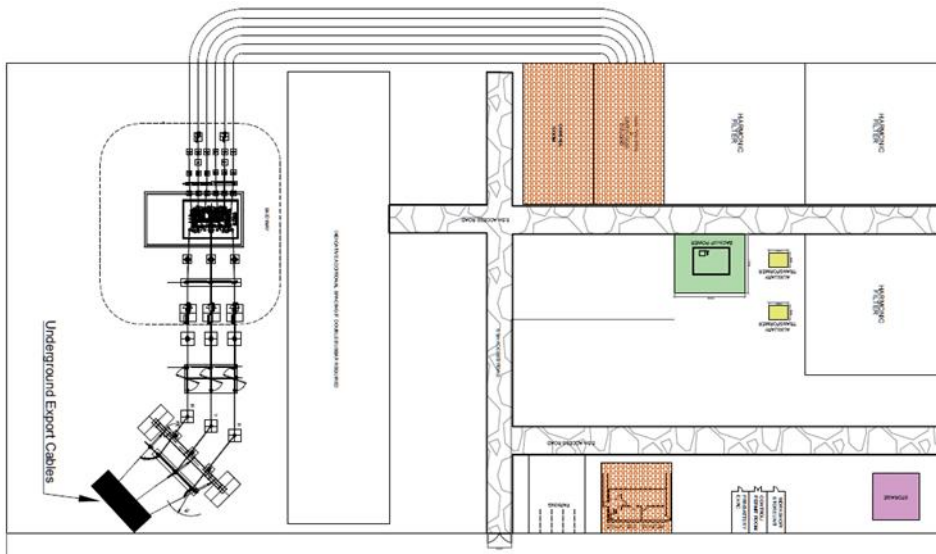

10.5 The substation area will be restored to comparable ALC grade at the decommissioning phase.

ALC Grade

10.6 The ALC grade of the Site is shown on the plan below, extracted from the ALC Plan.

Insert 40: Extract from the ALC

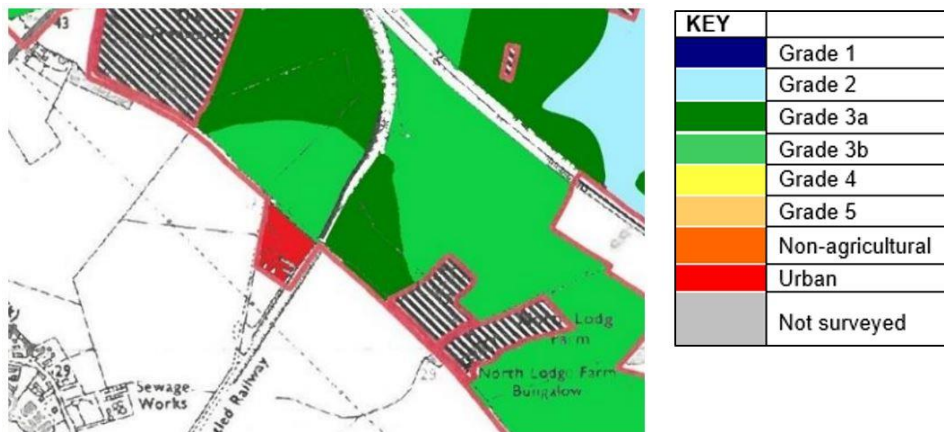

10.7 The area for the substation is therefore all Subgrade 3b.

Construction Methodology

10.8 A temporary construction compound will be created in the field to the north, also on subgrade 3b, following the guidance in section 5 of this oSMP.

10.9 The substation area will be constructed when soils are suitably dry to be handled. The topsoil will be stripped to a depth of 30cm and will be moved for long-term storage. Provided that the soils are suitably dry, this can be in bunds

of up to about 4m high, as set out in Defra's Code of Practice section 5.4, Appendix D.

10.10 The area for excavation, based on the illustrative plans, is about 2 ha. This will mean moving of the order of 6,000 cubic metres of topsoil.

10.11 The exact location for this to be stored will be agreed in the SMP. For this oSMP, the indicative storage areas are shown below, which would indicatively allow a 250m long bund of topsoil 12m wide and 3m high, equating to >6,000 cum. (approx. 27 cum/m length).

Insert 41: Indicative Bund Location

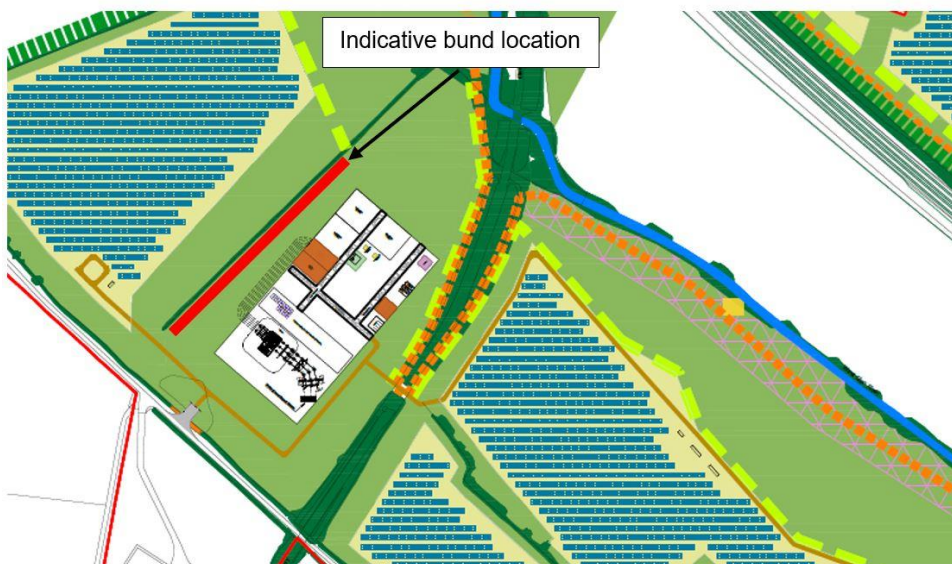

Maintenance of the Bund

10.12 The bund will be maintained as described in section 13.

Restoration

10.13 Prior to restoration, a detailed SMP will be prepared by a suitably-qualified soil surveyor. This will advise in detail on timing, taking account of potential seasonal changes as a result of climate change.

10.14 The soil surveyor and SMP will advise on the need for subsoils to be loosened prior to replacement of the topsoil.

10.15 Aftercare works will be incorporated into the SMP for decommissioning.

10.16 The restoration methodology will reinstate the land quality to the same land quality as the land immediately next to the area affected, as measured by the

ALC Revised Guidelines and Criteria (1988) or by any subsequent ALC methodology in force at decommissioning.

11 OPERATIONAL PHASE: LAND MANAGEMENT

11.1 During the operational phase the grassland within the Solar PV Arrays area as well as the mitigation and enhancement areas will be managed as set out in the oLEMP. The outline Operational Environmental Management Plan (oOEMP) includes a requirement for a programme of soil health monitoring to be undertaken which will be set out in the detailed OEMP (s).

11.2 The relevant section from the oOEMP is reproduced below.

Insert 42: Extract from the oOEMP

Table 3-8 Agriculture and Land Use

Potential Impact	Mitigation / Enhancement Measure	Monitoring Requirements
<p>Potential for surface soil compaction in some areas. For example, grassed access alleys traversed by light vehicles for site maintenance could cause surface compaction in damp or wet soil conditions. If sheep grazing is used for vegetation management surface compaction can result if numbers grazing are too great in wet conditions. Surface compaction can cause run-off.</p>	<p>The management of trafficking onsite and traversing the land when the soil is in a suitable dry condition is key to managing the risk of soil compaction.</p> <p>As a broad guide, planning of the maintenance works should take this into consideration and seek to undertake minimal traversing across the Solar PV Site and soil handling during the period early December to early April, and/or to develop appropriate procedures to do so such as the use of matting. An onsite inspection of the soil condition prior to vehicle movement across the Solar PV Site is essential.</p> <p>When travelling across the Order limits all machinery and vehicles should keep to internal access tracks where possible to minimise the risk of soil compaction.</p> <p>Soil mounds will be maintained at least annually during the life of the Proposed Development to prevent the establishment of woody growth or brambles, in accordance with the oLEMP.</p> <p>The detailed OEMP (s) must include the measures set out in the oSMP for managing soils during operation of the Proposed Development.</p> <p>The detailed OEMP (s) must set out a programme of soil health monitoring to be undertaken throughout the operation of the Proposed Development.</p> <p>Sheep numbers will be controlled in liaison with farmers to ensure that excessive grazing and trampling does not compact/degrade soils. Grazing land will be periodically inspected to check if overgrazing/trampling is occurring and this will be communicated with the farmers.</p>	<p>Soil assessments and monitoring will be undertaken as detailed in the oSMP [EN010127/APP/7.12].</p>

Solar PV Arrays

11.3 The Solar PV Arrays will be managed by the grazing of sheep or mown.

11.4 Panels grazed by sheep tend to be free of weeds, as shown below.

Insert 43: Sheep Grazing Under Panels



11.5 Any localised weed treatment can be carried out at the appropriate time of the year using a quad-mounted sprayer, or by hand using a strimmer or knapsack sprayer.

Ongoing Maintenance

11.6 There are many different cleaners on the market, some tractor based and some operated from smaller machines, such as below.

Insert 44: Cleaning of Solar Arrays



11.7 All the fields are wet in places, and therefore the cleaning should be timed so far as possible to avoid the December to March period for much of the site.

11.8 If vehicles, including farm vehicles, cause ruts in the soil these will naturally repair in time, especially as the land is grazed by sheep and their feet are excellent at levelling land.

Insert 45: Ruts Caused by Vehicles



11.9 If vehicles have caused rutting it is probably, as per the example above, only localised. In the photograph above this is a wet spot, and on the land either side of the ruts within the row there is no evidence of wheel indentation. If these areas are not levelled they will tend to sit with water in them.

11.10 In some cases rutting may be deeper. The following is a very wet area (the reedy vegetation shows this) and a repair was required. This will necessitate more active repair.

Insert 46: Deeper Rutting



11.11 Localised, small rutting should be repaired by either treading-in the edges with feet, or adding a small amount of soil simply to fill-in the depression so that water does not collect there. These areas should be monitored to ensure no further compaction occurs.

11.12 Deeper rutting will require either light harrowing in the drier period, or some soil adding, or both, before reseeding.

Emergency Repairs

11.13 For the duration of the operational phase there should be only localised and infrequent need to disturb soils, such as for repair of a cable. Any works involving trenching should be carried out, ideally, when the soils are dry but recognising that any works will be those of emergency repair, that may not be possible.

11.14 Accordingly if new cabling is needed and has to be installed in wet periods, it can be expected that the trench will look unsightly initially, such as the example below.

Insert 47: Trench During Wet Period



11.15 Any area disturbed should be harrowed or raked level once the soils have dried, and be reseeded. These areas will be small, and this can probably be done by hand.

Mitigation and Enhancement Areas

11.16 The Biodiversity Enhancement Area Management is described in the oLEMP as retained arable field parcels with skylark photos. There will be no requirement to traffic these areas when wet, and normal good agricultural management will be followed.

12 OPERATIONAL PHASE: SOIL STORAGE

- 12.1 The critical part of successful long-term storage of soils is to place the soils into storage bunds when the soils are dry.
- 12.2 Ongoing maintenance should ensure that the bunds remain free from woody vegetation (eg brambles, elder) and that the soil bunds do not erode. For this reason the bunds should be seeded with a grassland mix, as the roots of the grasses will help bind the surface and prevent water channels forming.
- 12.3 At least once per year the bund should be managed, ideally by mowing or strimming.
- 12.4 For the bund near to the substation, where a large bund is being created, it should be possible for a tractor with a hedge cutter attachment to travel along the top of the bund and mow the sides, or mow the sides from the base.

13 DECOMMISSIONING

13.1 Prior to decommissioning a detailed methodology will be developed, as set out in the oDEMP. The relevant section is reproduced below.

Insert 48: Extract from the oDEMP

Table 3-8 Agriculture and Land Use

Potential Impact	Mitigation and/or Enhancement Measure	Requirement for Monitoring
Impacts on soil	<p>The oSMP [EN010127/APP/7.12] and oEMMP will inform decommissioning works to minimise the damage to soil structures during the decommissioning phase, and provide amelioration to any localised impacts using good agricultural practices. The oSMP will inform the preparation of a SMP (incorporating the EMMP) prepared prior to decommissioning which will:</p> <ol style="list-style-type: none"> a description of the soil types and their resilience to being trafficked; an outline description of proposed access routes and details of how access will be managed to minimise impacts on soils; a description of works and how soil damage will be minimised and ameliorated; and a methodology for monitoring soil condition, and criteria against which compliance will be assessed. <p>The DEMP(s) will consider access routes to ensure ongoing access for husbandry and any land being cropped during the decommissioning process, and to the need to adhere to precautions to minimise the risk of any spread of plants and seeds between holdings.</p> <p>The DEMP(s) will include measures to liaise with landowners and negotiate closure or severance of field accesses at key times of the farming year to mitigate potential short-term effects on farm businesses and enterprises as a result of decommissioning.</p>	None.

13.2 The objective is to remove panels and restore all fixed infrastructure areas to return the land to the same ALC grade and condition as it was when the construction phase commenced.

Removal of Panels

13.3 A qualified soil scientist should advise at decommissioning time, however. The effects of climate change in 40 years time may mean that these dates, applicable in 2023, are no longer applicable.

13.4 The framework will then be a series of legs, as shown below.

Inserts 49 AND 50: The Framework





- 13.5 These will be removed by low-ground pressure machines, in a reverse operation to the installation. These machines will provide a pneumatic tug-tug-tug vertically upwards. This will break the seal between soil and leg, and once that surface tension is released the leg will come out easily.
- 13.6 The legs will be loaded onto trailers and removed.
- 13.7 There will be no significant damage to the soils, and no significant compaction.

Removal of Cables

- 13.8 Cables buried less than 1 metre deep will be removed. This is likely to need a trench to be dug. This will be done is done mostly with either a mini digger or a trenching machine. Trenches will mostly be at depths of 0.8 – 0.9m where soil depth permits, although the CCTV trenching around the periphery could be shallower. An example trench, with the topsoil placed one side (0-20/25cm) and subsoil on the other (below 20-25cm), is shown below, and with the soil put back after cable installation.

Insert 51: Example Trench



Insert 52: Topsoil Replaced



13.9 The type of machinery used for trenching is shown below, taken from the BRE National Solar Centre “Agricultural Good Practice Guidance for Solar Farms” (2013) (this is reproduced as **Appendix D**).

Insert 53: Machinery Used for Trenching



Cable trenching, showing topsoil stripped and set to one side, with subsoil placed on the other side ready for reinstatement (photo courtesy of British Solar Renewables)

13.10 Once the trench has been backfilled it can be left for cultivation with the rest of the field post removal of panels.

Removal of Fixed Infrastructure

13.11 Switchgear, such as that shown below, will need to be removed.

Insert 54: Switchgear



13.12 Low ground pressure vehicles, and cranes, will be needed to lift the decommissioned units onto trailers, and removed from site. An example is shown below.

Insert 55: Example of Low Ground Vehicles



Case Steiger Quadtrac used to deliver inverters and other heavy equipment to site under soft ground conditions (photo courtesy of British Solar Renewables)

13.13 Any concrete bases will need to be broken up. This will most likely involve breaking with a pneumatic drill to crack the concrete, after which it can be dug up and loaded onto trailers and removed.

13.14 The ground beneath the base may then benefit from being subsoiled, to break any compaction. This can be done by standard tractor-mounted equipment, such as the following examples.

Inserts 56 and 57: Example of Tractor Mounted Equipment



Tracks

13.15 The tracks will be the last fixed infrastructure removed. The tracks will have been used for vehicle travel during the decommissioning stage. The tracks will also be used for removal of material from the tracks themselves, which will be removed from the furthest point first.

13.16 The stone will be removed and any matting removal. The base will then be loosened by subsoiler or deep tine cultivators, depending on specific advice given by the soil expert at the time following and analysis of soil compaction and condition.

Reinstatement of Soils

13.17 Topsoil from the storage bunds will then be returned and spread to the depth removed as informed by the ALC survey results (typically 10-15cm). The area will then be cultivated, probably in combination with the whole of each field.

13.18 The restoration methodology will reinstate the land quality to the same land quality as the land immediately next to the area affected, as measured by the ALC Revised Guidelines and Criteria (1988) or by any subsequent ALC methodology in force at decommissioning.

Fences and Gates

13.19 This will be removed in the summer months, after the panels have been removed. This will involve a tractor and trailer. The CCTV cabling is shallow buried and will probably pull out without the need for trenching, but if required trenches will be dug, as described above, and replaced in order once the cables have been removed

Cultivation

13.20 The fields will be handed back to the farmers. Whether they are handed back as grassland or sprayed off and cultivated, will be determined in discussions with each landowner.

14 MANAGEMENT AND MONITORING

- 14.1 The *oOEMP* and *oLEMP* set out how the grassland under the PV Arrays are likely to be managed during operation of the Proposed Development.
- 14.2 There is no requirement for annual monitoring or reviews of aftercare in respect of soil management.



Greenacres Barn, Stoke Common Lane, Purton Stoke, Swindon, Wiltshire SN5 4LL
Telephone: 01793 771333 • Email: info@kernon.co.uk • Website: www.kernon.co.uk



Appendix A
Distribution of Soil Types

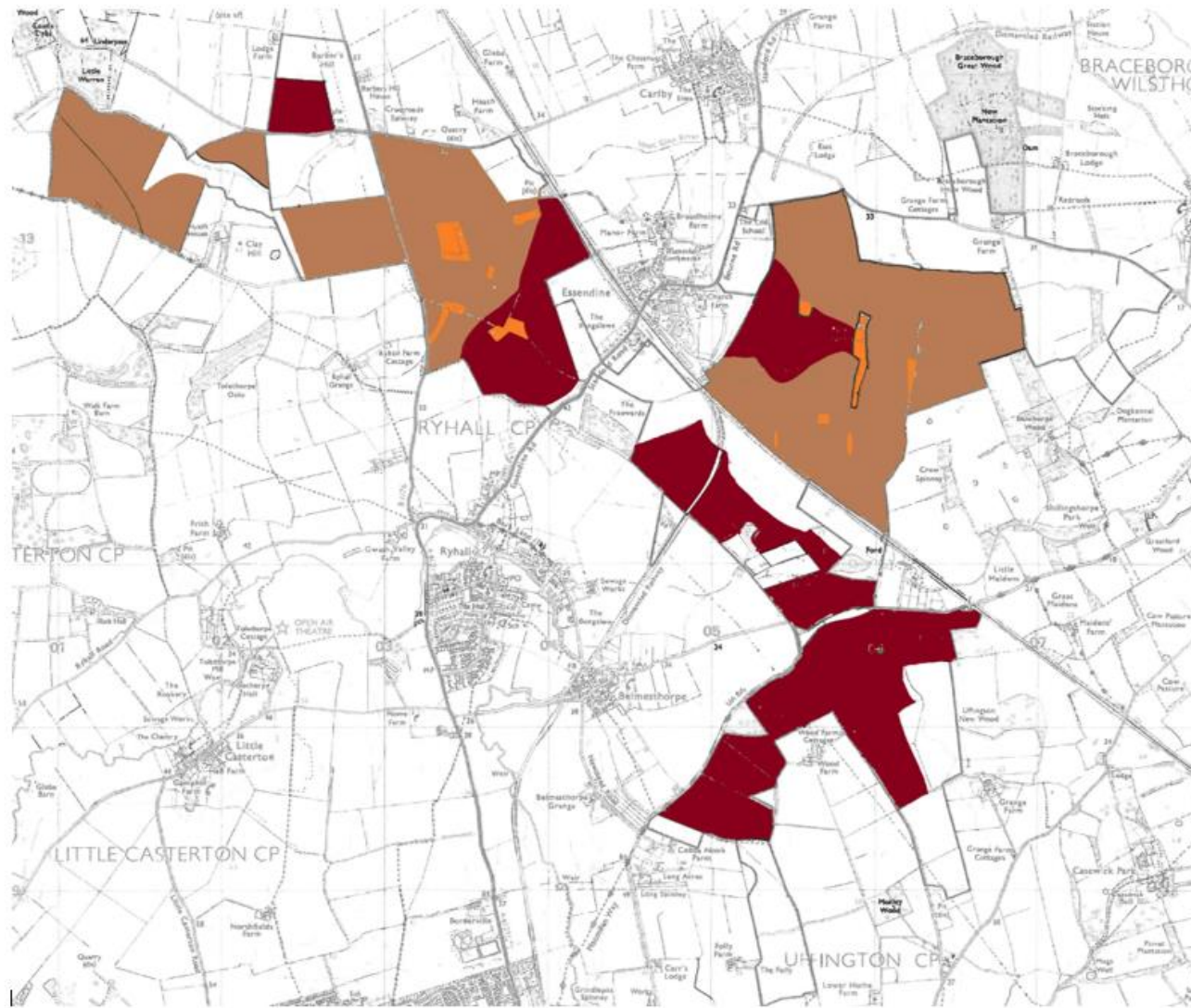

KEY	
	Heavy Clay Soils
	Medium Clay Soils

PLAN	KCC3051/05		
TITLE	Distribution of Soil Types		
SITE	Mallard's Pass		
CLIENT	LDA Design		
NUMBER	KCC3051/05 07/22tk		
DATE	July 2022	SCALE	NTS

KERNON COUNTRY SIDE CONSULTANTS LTD
GREENACRES BARN, PURTON STOKE, SWINDON,
WILTSHIRE, SN5 4LL
Tel 01793 771 333 Email: info@kernon.co.uk
This plan is reproduced from the Ordnance Survey
under copyright license 100015226

Appendix B

Good Practice Guide for Handling Soils in Mineral Workings

IQ

The Institute
of Quarrying



Good Practice Guide for Handling Soils in Mineral Workings

GOOD PRACTICE GUIDE FOR HANDLING SOILS

In Mineral Workings

Published in the UK by:

The Institute of Quarrying

McPherson House
8a Regan Way
Chetwynd Business Park
Chilwell,
Nottingham
NG9 6RZ

www.quarrying.org

© 2021 The Institute of Quarrying

All rights reserved. No portion of this publication may be reproduced, stored in a retrieval system or transmitted at any time or by any means mechanical, electronic, photocopying, recording or otherwise without prior, written permission of the publisher.

The information in this publication is general guidance on the best practices and approaches to soils guidance. Specialist advice should always be sought if you need more details about what action to take in your own circumstances.

First Edition published 2021.

For over 100 years the Institute of Quarrying has been supporting people working in the mineral extraction industry. It is the only international professional body for quarrying, construction materials and the related extractive and processing industries. IQ's focus is to be the global leader in standards for the sector, to push innovation and operational best practice, to support the industry in driving healthy, sustainable workplaces and to promote the positive impact of the industry and profession. Being a member of IQ means being part of a global community of industry professionals committed to sharing knowledge and improving industry standards.

GOOD PRACTICE GUIDE FOR HANDLING SOILS

In Mineral Workings

PART ONE: Introduction

Contents

Part One

Introduction

05	Foreword
06	Acknowledgements
07	Preface
09	Introduction
10	Key Issues
15	Choosing Machinery Combinations, Handling & Remedial Practices
26	Supplementary Note 1 – Soils
30	Supplementary Note 2 – Soil Resource & Management Plan
31	Supplementary Note 3 – Compaction
35	Supplementary Note 4 – Soil Wetness
38	Supplementary Note 5 – Soil Mixing
39	Glossary of Terms

Contents

Part Two

Model Methodologies

40	<u>SHEET A</u> Soil stripping with excavators and dump trucks – Sequential bed/strip practice
48	<u>SHEET B</u> Building soil storage mounds with excavators and dump trucks
54	<u>SHEET C</u> Excavation of soil storage mounds with excavators and dump trucks
59	<u>SHEET D</u> Soil replacement with excavators and dump trucks – Sequential bed/strip practice
71	<u>SHEET E</u> Soil stripping with excavators and dump trucks – Windrow practice
80	<u>SHEET F</u> Soil stripping with bulldozers and dump trucks – Windrow practice
88	<u>SHEET G</u> Building soil storage mounds with bulldozers and dump trucks
94	<u>SHEET H</u> Soil replacement with bulldozers and dump trucks – Windrow practice
104	<u>SHEET I</u> Soil stripping with bulldozers and dump trucks – Modified layer by layer practice
111	<u>SHEET J</u> Soil replacement with bulldozers and dump trucks – Modified layer by layer practice
121	<u>SHEET K</u> Hybrid soil replacement with excavators, bulldozers and dump trucks – Modified layer by layer practice
132	<u>SHEET L</u> Release and removal of stones and non-soil debris by excavator and stoke-rake
138	<u>SHEET M</u> Release and removal of stones and non-soil debris by bulldozer drawn tines
144	<u>SHEET N</u> Soil decompaction by excavator bucket
150	<u>SHEET O</u> Soil decompaction by bulldozer drawn tines

Foreword

Over the past twenty years the MAFF guidance has been widely used by the mineral industry and planning authorities, and their advisors. With the recent changes in land use (natural capital) and environmental (climate and biodiversity) related policies it is appropriate that the guidance is updated and expanded to include these.

In recognition of this, the Institute of Quarrying undertook to update the guidance in consultation with Natural England and the Welsh Government. This was with the support and guidance of a Steering Group representing the minerals industry, mineral planning authorities, and professional bodies and specialist consultants.

Attention is rightly focused on soil natural capital to ensure that the natural resource is left in a measurably better state than beforehand. Environmentally positive policies are increasingly driving operational practices, and as the professional membership body for the quarrying and aggregates sector, the Institute believes it is critical to provide current guidance that supports better performance outcomes for the industry. The Institute of Quarrying is proud to have worked with all of the stakeholders on the project to revise and update this guidance and also thank you to all those who have contributed.

James Thorne
Chief Executive
The Institute of Quarrying
July 2021

Acknowledgements

Author

Dr R N Humphries CBiol CSci FRSB FBSSS FIQ
Blakemere Consultants Ltd & Celtic Energy Ltd

Steering Group

R J Smallshaw	Steering Group Chair and Institute of Quarrying
J Holloway	Natural England
A W Williams	Welsh Government
B Pilgrim	Banks Mining
M Young	Breedon Group
G Watkins	Hanson UK
L Gilbert	HS2 Ltd
D Park	Tarmac a CRH Company
A Hawkes	Chepstow Plant
M Tweddle	Durham County Council
S Elson	Surrey County Council
S Warren	British Aggregates Association
B Lascelles	British Soil Science Society
I Briggs	Landesign Planning and Landscape Ltd
I Meadows	Meadows Archaeology

Dr S G McRae (Consultant), Dr N A D Bending (Progressive Restoration), R Stock (Consultant), V Redfern (Consultant) and R J K Thompson (Celtic Energy Ltd) kindly provided further comments and insights.

The supporting art work was provided by R Shelton (H J Banks & Co) and D Fisher (Blue Room Graphics Ltd).

Preface

In 2000 MAFF published its Good Practice Guide for Handling Soils by a range of earth-moving machines. This was a comprehensive guide to soil handling practices to help achieve a high standard of reclamation for mineral extraction sites across all agricultural land qualities (DoE 1989; DETR 1999; Welsh Assembly Government 2004 & 2009; Welsh Government 2021). It also contributed to the drive to achieve a more sustainable use of soils (DEFRA 2009a & 2009b).

The focus of current UK Government policy in England, as set out in its 25 Year Environmental Plan (DEFRA, 2018), is to safeguard soil resources (as Natural Capital, DEFRA, 2021) and that by 2030 for all soils to be managed sustainably. The same objective of Sustainable Management of Natural Resources (SMNR) is encompassed in the Environment (Wales) Act (National Assembly of Wales, 2016). Good quality agricultural soils are to be protected and all soils are to be fully valued for their environmental and ecosystem services and are to be better managed to improve soil health. The purpose of this updated guidance is to assist the mineral industry in their contribution by achieving sustainable soil based after uses and that impacts on the soil resources and soil functions are minimised and enhanced wherever possible.

The purpose of **Part One** of the Institute of Quarrying's updated guidance on good soil handling practice by machines is to provide an overarching explanation of the context and aims of the model methods given in Part Two.

In addressing the new Natural Capital driven policies for protection of soil resources and their sustainable management, soil compaction and its associated limitations on soil functions has long been known to be the main adverse effect of handling and trafficking soils with earth-moving machines.

It remains the primary challenge for successfully achieving the intended after uses and the maintenance provision of defined environment

and ecosystem services, and the associated soil functions associated with healthy soils. Whilst the occurrence and degree of compaction is related to the choice of machinery combination and handling practice, they are also a function of the type of soil and wetness of the soils at the time of handling.

The prime aim of the guidance is to minimise the compaction of soils as they are handled with the minimal reliance on the need for remedial treatment of compaction caused by the machinery and handling practices. Hence, in the updated guidance greater attention is given to the wetness of soils during handling operations.

It also introduces the key role of the Soil Resource & Management Plan. This should be the primary reference material for characterising the soil resources available, informing and successfully delivering the intended after use(s) whether it is agricultural, horticultural, forestry, semi-natural vegetation/ecosystems or other soil-based ones. It will underpin the operational design, land use and landscaping plan, and the practices needed to be deployed, and the means of communication to all those involved. The importance of competency in the technical understanding of soils and the implications of the operational practices is also emphasised.

The familiar MAFF presentation of the model methods as individual 'Sheets' has been retained in Part Two for everyday communication to all levels of users. Model methods are provided for the two widely used machinery combinations of excavators & dump trucks, and bulldozer & dump trucks. The MAFF model methods for the use of earth-scrapers are no longer included but can be found in the National Archive (DEFRA, 2009c, Sheets 5 to 8).

Model methods are provided for the three most commonly used soil handling practices (the 'bed/strip', the 'windrow/peninsular' and the layer by layer).

A method for an alternative 'loose-tipping' approach (using excavators for the subsoil and bulldozer for the topsoil) is a new addition.

The processes of decompaction and the removal of stones/non-soil debris in the soil replacement procedures are now integrated into the method sheets.

It is intended that this guidance remains as a 'live' document and is updated with site experiences and future developments in mineral extraction.

References

[Department of the Environment, 1989. Minerals Planning Guidance 7: Restoration of Mineral Workings \(paragraph 2\)](#)

Department of the Environment Transport & the Regions, 1999. A better quality of life: a strategy for sustainable development for the United Kingdom (paragraphs 6.66 and 8.50). Stationery Office, London

[Department of Environment, Food & Rural Affairs, 2009a. Safeguarding Our Soils: A strategy for England](#)

[Department of Environment, Food & Rural Affairs, 2009b. Construction Code of Practice for the Sustainable Use of Soils on Construction Sites](#)

[Department of Environment, Food & Rural Affairs, 2009c. Good practice guide for handling soils](#)

[Department of Environment, Food & Rural Affairs, 2018. A Green Future: Our 25 Year Environment Plan to Improve the Environment](#)

[Defra, 2021. Enabling a Natural Capital Approach: Guidance - GOV.UK \(www.gov.uk\)](#)

[National Assembly of Wales, 2016. Environment \(Wales\) Act](#)

[Welsh Assembly Government, 2004. Minerals technical advice note \(MTAN\) Wales 1: aggregates](#)

[Welsh Assembly Government, 2009. Minerals technical advice note \(MTAN\) Wales 2: coal](#)

[Welsh Government, 2021. Planning Policy Wales - Edition 11](#)

Introduction

Minerals are recognised as essential Natural Capital, providing for our modern society and its wellbeing, as are the soil that covers the mineral resource (Wikipedia, 2020).

Soils provide essential environmental and ecosystem services, such as food, water regulation including water infiltration and flood avoidance, carbon storage, and biological functioning. Consequently, current planning and environmental policy not only protects good quality agricultural soils but also focuses on the sustainable management of all soil resources and to ensure their ecosystem services are fully valued and their use is sustainable. Hence, the machines and handling practices used in the recovery and conservation of soil resources (Humphries et al, 2018), and their reuse in the reclamation of mineral extraction sites will be material considerations in the granting of planning consent.

The updated guidance is intended for use by planning officials, statutory consultees, mineral operators and their supporting teams and specialist consultants, and earth-moving contractors, their site supervisors and machine operators. It has key

roles to play from i) the inception of projects and their development through to the application and securing of planning consent, and to operational implementation, to ii) providing the basis for training modules. Its adoption throughout all these stages processes should ensure that the necessary actions are addressed and communicated to all those involved (**Figure 1**) and that they are fully informed as appropriate so that the best results possible are achieved.

In **Part One** the important aspects of soil handling are introduced under the headings of Key Issues and Choice of Machinery Combinations, Handling & Remedial Practices, and these are supported by Supplementary Notes.

KEY ISSUES

- Health & Safety
- Soil Natural Capital, Soil Function & Ecosystem Services
- Soil Resource & Management Plan
- Soil Compaction
- Soil Wetness
- Monitoring & Recording
- Planning Conditions & Control

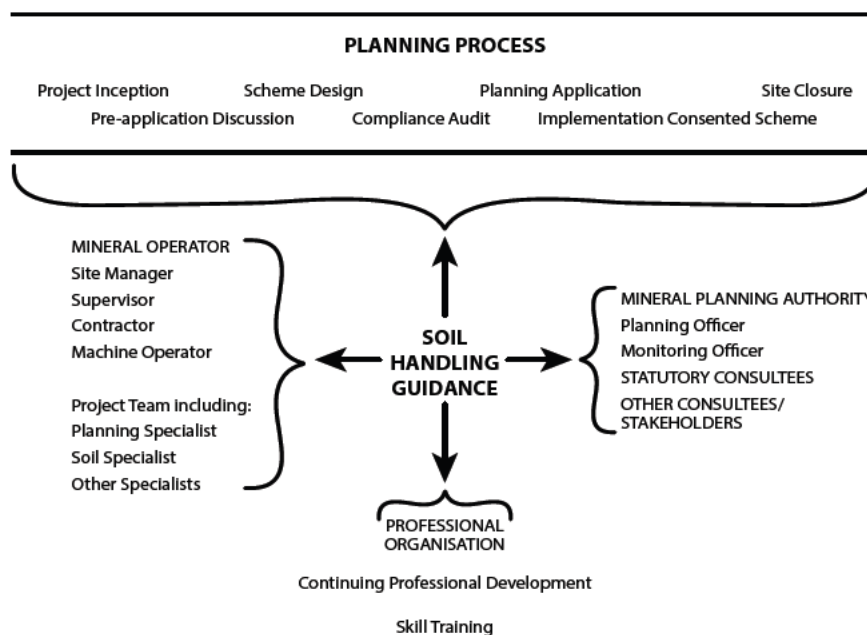

Figure 1: Key informative and training role of the soil handling guidance in the development and reclamation of mineral workings.

Choosing Machinery Combinations, Handling & Remedial Practices

- Health & Safety
- Available Machinery Combinations
- Commonly Deployed Soil Handling Practices
- Available Remedial Practices
- Relative Risk of Significant Compaction: Machinery combinations & Handling Practice / Soil Storage / Efficacy of Soil Recovery / Relative Susceptibility to Rainfall Delays
- The Deployment of Earth-moving Machinery & Handling Practices
- Remedial Treatment of Compaction
- Removal of Stones and Non-soil Debris
- Cultivations Following Soil Replacement
- Under-Drainage
- Vegetation Cover

Supplementary Notes

- 1. Soils
- 2. Soil Resource & Management Plan
- 3. Soil Compaction
- 4. Soil Wetness
- 5. Soil Mixing

Part Two provides detailed model methods of best practice for each machinery combination and soil handling practice. However, in doing so the guidance does not specify size, make or model of equipment as this is left to the mineral operator and/or contractor to specify, justify and provide.

KEY ISSUES

Health & Safety

Of overriding importance is the issue of safety. All persons involved in the handling of soils must comply with all relevant legislation with respect to Health and Safety, in particular the Health and Safety at work Act 1974 (UK Government, 2020a) and in the case of mineral extraction operations The Quarries Regulations 1999 (UK Government, 2020b) and its relevant statutory provisions, especially those aspects which relate to the construction and removal of tips, mounds and similar structures.

The users of this guidance are solely responsible for ensuring all activities comply with safety legislation

and good practice, including the manufacturer's specifications for the safe operation of the specific machines being used, and that all machines are in a good condition and well maintained. The machines must be of a kind which are appropriate for the task and the outcomes required and can carry out the work safely and efficiently. These requirements take preference over any suggested practice in this guidance. For example, the position and orientation of an excavator on handling soils which could affect its stability, and the positioning and proximity of other machines as described in the text and shown in the illustrations.

It is important that those involved in the operation of earth moving machines are competent and have the necessary training and certification.

Soil Natural Capital, Soil Function & Ecosystem Services

The concept of Natural Capital, from which we as human society derive the benefits of supporting, provisioning, regulating and cultural environmental/ecosystem services, will become firmly established in future land use policy and decision making by central and local government (UK Government, 2020c).

Natural Capital includes soil, minerals, water, and other natural resources. Soil based ecosystem services provide food and fibre, regulate water quality and drainage, store carbon and help regulate greenhouse gases, support biodiversity and biological functioning of soil, and is the basis of our modern-day culture. Hence, the services they provide are an important consideration in the exploitation and reclamation of mineral sites.

Soils with different textures and structure differ in their land use capability and level of environmental and ecosystem services provided. The composition and condition (or health) of soils, and their functioning, can be significantly altered during soil handling. This can have consequences for the subsequent delivery of environmental/ecosystem services and the after use of land and can be costly to remedy. Losses and degradation of soil natural capital and its services can be a consequence of the soil machinery and handling practices used.

Hence, the characterisation of the affected soils (see Supplementary Note 1) will be an important factor in determining the choice of machinery combination and handling practice.

Soil Resource & Management Plan

A Soil Resource & Management Plan (SRMP) (see Supplementary Note 2) is an essential component and integral part of the updated guidance. It has a key role in achieving the successful delivery of the intended after use, and the conservation and functioning of soil resources in mineral extraction schemes. It should be the prime source of soil resource and handling information (British Society of Soil Science, 2021; Natural England, 2021), and used as the means of communication to all those involved in the design and specification, decision making, and oversight and audit of the scheme from a project inception and development through all the stages from the planning application to site closure (Figure 2). It is also a means whereby everyone involved can be updated and liaise regularly to ensure the best results possible are achieved.

The SRMP comprises essentially:

- i) a field survey to characterise in detail the

soil resources on the site and where agricultural land, the associated agricultural land classification grades,

- ii) develops the baseline information into a soil handling and management plan describing in detail how the site is to be developed during mineral extraction, and
- iii) its reclamation (restoration & aftercare).

It should contain location of the mineral, and any other relevant site, operational and infrastructure details (see Supplementary Note 2). Successful soil handling and restoration schemes are dependent on having a detailed soil resource survey (including an ALC where needed) to be undertaken by appropriately qualified and experienced soil specialists (British Society of Soil Science, Undated) which are then interpreted into practical soil advice on scheme design and phasing, identifying any particular constraints and opportunities for future after-uses, proposals for stripping and replacement soil units, along with any particular requirements.

The SRMP must show the soil resources to be recovered or substituted (as soil forming materials, Bending et al, 1999) and their use in the

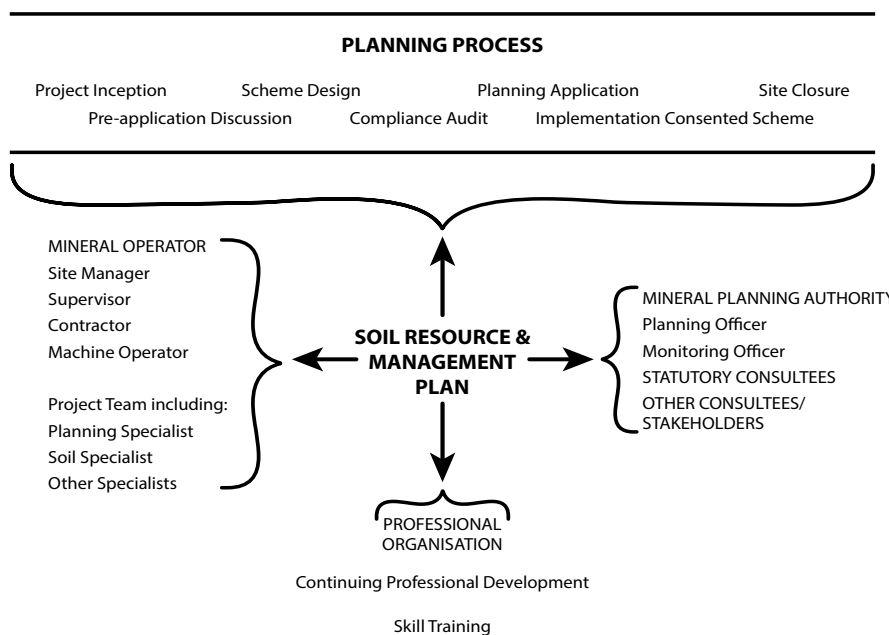

Figure 2: Key informative role of the soil resource & management plan in the development and reclamation of mineral workings

replacement scheme appropriate to the intended after uses and ecosystem services to be provided. In consultation with the mineral operator and planning authority, having taken the safety constraints (such as ground conditions, gradient) into account, the SRMP should state the type of earth-moving machinery, specify the handling, storage and remedial practices to be deployed to achieve the intended after use, and the provisioning of environmental and ecosystem services.

The SRMP should show where the access and haul routes and soil storage areas are to be located and their progressive development throughout the operations.

In most cases the areas for infrastructure, haul routes and those soil storage areas are to be stripped of soils before the rest of site is developed. The SRMP should identify any deviation from good soil handling practices, for example where haul routes may have to be upon the in-situ topsoil because of low load bearing capacity of the lower soil profile or underlying material. This may also be the case where there is known archaeological that need to be protected prior to ground investigations taking place.

The occurrence of other constraints/influences on the selection of machinery and/or handling practice, and the contingencies to be made should be included in the SRMP. For example, the occurrence of buried archaeological artefacts can determine the soil stripping practice (**Table 1**) or the occupation of the affected land by ground nesting birds (UK Government, 2021a) can delay or modify operations too late in the season.

The SRMP should include the rainfall and soil moisture limits the soil handling operations are work to and agreed with the Planning Authority before determination and included in the earth-moving contract.

Importantly, the SRMP should identify the roles and responsibilities of those involved, and the details of monitoring and reporting to take place. The soil handling provisions within the SRMP are to be communicated to all those carrying out the work and in particular the site supervisors and machine operators by appropriate means, including detailed plans, toolbox talks and site demonstrations.

Supervision by trained staff is essential, as is the monitoring and reporting by competent

Machinery Combination & Handling Practice (see Part Two)	Watching brief	Investigation & recording
Excavator – Dump Truck Using Bed/Strip Practice (Sheet A)	Suitable	Not suitable
Excavator – Dump Truck Using Windrow/Peninsular Practice (Sheet E)	Suitable	Suitable
Bulldozer – Dump Truck Using Windrow/Peninsular Practice ¹ (Sheet F)	Not suitable	Not suitable
Bulldozer – Dump Truck Using Modified Layer by Layer Practice (Sheet I)	Not suitable	Not suitable

Table 1: Likely Suitability of Soil Handling Methods for Archaeological Investigations

soil specialists (British Society of Soil Science, Undated).

Soil Compaction

Compaction within the replaced profile is the most common problematic condition of replaced soils (Reeve et al, 2000). It is often overlooked as a factor inhibiting the successful delivery of the intended after uses, function and services, resulting in poorer growth of crops or other vegetation, reduced water infiltration and storage leading to enhanced risk of run-off, erosion and flooding, and reduced soil aeration and normal biological functioning with risk of increased emissions of nitrous oxides (potent greenhouse gases). Whilst the risk of compaction is exacerbated by handling soils when wet (Duncan & Bransden, 1986), it can occur in drier conditions through excessive machinery trafficking. The degree and significance of effect is likely to vary between the types and size of machinery used and the handling practice adopted, soil textural class and soil wetness condition (see Supplementary Note 3).

Whilst some degree of remedial effect can be achieved where appropriate equipment is used and the soil mass is sufficiently dry to enable shattering (Bacon & Humphries, 1987; Dunker et al, 1992; Spoor, 2006), experience has demonstrated that practices which minimise the trafficking of the soil by machinery is the more effective and reliable option (Bransden, 1991; Reeve et al, 2000). However, for some after uses, such as wetland ecosystems where the drainage is to be impeded, some compaction within or below the soil layer may be necessary to create the required wetness condition. For other habitats the deliberate degradation of soil functions (e.g., fertility and drainage) by soil mixing or other means may be necessary to achieve particular habitat creation schemes (see Supplementary Note 5).

Advice is given in **Part Two**, Sheets S & T, on the use of the two remediation options available, and when and how they should be integrated into the soil replacement process, and the monitoring of their efficacy.

Where relevant, these are likely to be specified in

the planning consent and should be stated in the SRMP and agreed with the planning authority.

Soil Wetness

There are two causes of soil wetness;

- i) the inherent water regime of the soil (wetness class) based on the average duration of waterlogging at different depths and determined by reference to soil characteristics and local climate (MAFF, 1988)
- ii) the shorter-term effect of individual rainfall (precipitation) events.

Historically, soil water content and variations in climate across England and Wales has been a significant and sometimes an overlooked factor in determining the delivery of some intended after uses and services, such as productive agriculture and forestry. An increase in soil water content (soil wetness) increases a soil's susceptibility to compression and smearing (compaction) during all handling operations (Duncan & Bransden, 1986). The resulting compaction degrades the soil's ability to recover functionally and hence the delivery of the intended after uses and services (see Supplementary Note 4).

The degree of effect due to soil handling is likely to vary between the soil textural class, structural condition, and organic matter content, the local climate and daily weather conditions, but also between the types and size of machinery used and handling practice adopted. The primary cause of compaction arises from the compression caused by trafficking by the machinery and stockpiling of soil in storage.

Whilst some degree of remedial actions might be possible, experience has demonstrated that minimising compaction by handling soil in a dry condition is the more effective and reliable, and likely most cost-effective option.

Action can be taken to minimise the consequences of soil wetness through the timing of operations to coincide with the drier season (Reeve, 1994), the maintenance of a transpiring vegetation cover and site drainage and allowing exposed soils to dry out

after significant rainfall events (see Supplementary Note 4). Although the practice of windrowing soils is suggested as a mitigation measure (DEFRA, 2009b), it is likely to cause additional damage by the handling and should not be relied upon in mineral extraction schemes.

It is likely that when soils are in a wet condition the issues of unsafe operation and inefficient working will arise. Here, it is a joint operational, environmental and soil protection decision by those responsible for whether handling should start, continue, cease, or restart.

Advice is given in Supplementary Note 4 on the general timing of operations and a field-based determination of when the actual operations should start, cease or restart based upon actual soil wetness. This process should be set out clearly in the SRMP and agreed with the planning authority, along with a mechanism whereby further consultation and amendments can take place as circumstances arise.

Monitoring & Reporting

The requirement for monitoring and reporting during the operational stages of a mineral extraction scheme is an integral part of the soil handling process (Natural England, 2021). The details of which would be agreed with the planning authority and set out in the Soil Resource & Management Plan or if not, it should be required as a planning condition. The monitoring would provide the basis for any actions needed in the subsequent aftercare period. Importantly, the SRMP provides a factual basis for compliance and completion audits by the planning authority Monitoring Officers in their oversight and regulation roles of mineral extraction schemes.

General compliance monitoring recording of the actual practices used is likely to be undertaken by the planning authority, but regular soil audits and assessments for specific soil conditions (soil wetness and compaction) should be by competent soil specialists (British Society of Soil Science, Undated).

Standard methods for soil physical conditions, soil

structure and Soil Wetness Class are described in Hodgson (1997), MAFF (1982) and (MAFF, 1988) respectively. In addition, visual assessment methodologies (Ball & Munkholm, 2015; Ball et al, 2017, SRUC, 2021) for soil structure and function are now widely deployed and often in conjunction with other determinations such as organic matter content and micro-biological activity (Humphries et al, 2019). Without this basic information it will not be certain if the intended soil functioning and ecosystem services have been met by the choice of practice and machinery, and by subsequent aftercare actions.

Planning Conditions & Control

Soil resources and handling practice is likely to become more of a significant planning consideration for all future mineral developments given the recent focus on the sustainable management of soil natural capital (UK Government, 2014; UK Government, 2020c). This would require the provision of all relevant soil information about the development site and its after use before determination can be made by the planning authority, whether or not a scheme falls within the Environmental Impact Regulations.

In the past for those requiring an Environmental Assessment the information was usually provided in the submission even though the same and further information was often required to be resubmitted subsequently by means of a planning condition. The reliance on multiple submissions often resulted in discrepancies between the application and conditioned proposals. It should be made clear at the pre-application scoping/consultation and during the pre-determination stage that an integrated and comprehensive Soil Resource & Management Plan (SRMP) is required to enable planning determination and not a matter of subsequently requiring it as a planning condition, as often has been the case. In doing so, the SRMP should be required by a suitable planning condition to be updated prior to development and thereafter annually throughout site development, its reclamation (restoration and aftercare) (DEFRA, 2005).

If the methodology needs to be modified or changed, for example due to site conditions, this

should be agreed in advance with the mineral planning authority and documented by updating the SRMP.

Given that planning consents are legally enforceable, it is essential that there is an appropriate level of flexibility provision in the SRMP to enable speedy resolution of unexpected and insignificant operational or soil resource issues that arise during active soil movement operations. It would be expected that the SRMP would set out a protocol for the scope and consequences for the planning authority and its advisors to deal with what might be such instances as needing a change in machinery and/or practice. Hence, it is essential that appropriately detailed site studies and assessments are undertaken in the first instance by appropriately qualified and experienced personnel. However, significant changes to a scheme and the SRMP, such as replacing soils that were not capable of supporting agriculture when that was the original scheme, would probably need to be dealt with through a Section 73 planning application (UK Government, 2020d).

CHOOSING MACHINERY COMBINATIONS, HANDLING & REMEDIAL PRACTICES

Health & Safety

The primary decision as to which machinery and practices to be used is a matter of operational safety and those who have this responsibility. Commonly occurring limiting safety factors are gradient, topographical complexity, and ground stability.

Those of the trafficability of haul routes on areas stripped of soil due to surface wetness can be managed by the stoppage of works to allow the drying or the deployment of bulldozers/ graders to remove the slurry or the laying of a suitable surface etc.

Available Machinery Combinations

The most commonly used machine combinations for stripping, storage and replacement operations for mineral extraction schemes in the UK are either, excavators with dump trucks (**Part Two**, Sheets A – D, & E) or bulldozers (with an excavator to load

the dump truck at soil stripping) and dump trucks (Sheets F – H). A hybrid combination of excavator replaced lower soil horizons with bulldozer spread topsoil tipped from dump trucks is sometimes deployed (Sheet K). Other machines such as graders and bulldozers are usually deployed in the maintenance of haul roads (Humphries et al, 2018).

Commonly Deployed Soil Handling Practices

Guidance is given in **Part Two** on the three commonly used handling practices deployed in mineral sites for soil stripping and replacement.

These are:

- i) the 'bed/strip by strip' (Sheets A & D),
- ii) the 'windrow/peninsular' (Sheets E, F & H) and
- iii) the modified 'layer by layer' methods (Sheets I, J & K).

The replacement using the bed/strip system with excavators and dump trucks is often referred to as 'loose soil tipping', but generally are also truck tipped soils graded using bulldozers.

Available Remedial Practices

During the course of soil replacement actions may be needed to treat significant compacted soil layers (**Part Two**, Sheets N & O) and/or to remove stones and debris such as concrete slabs and wire-rope (Sheets L & M).

The commonly used practices are to deploy bulldozer drawn tines or excavators with specialist stone-rake buckets. Their deployment of these is integrated into the updated model method Sheets for soil replacement.

Relative Risk of Significant Compaction

Machinery Combination & Handling Practice

The risks of soil compaction, efficacy of soil resource recovery and replacement, and susceptibility to rainfall interruptions differ between the machinery combinations and handling practices. This should be addressed in the Soil Resource & Management Plan.

The risk of significant compaction and susceptibility of different soil horizons should be a particular

consideration when determining the likelihood of delivery of the intended after use.

The inherent risk is largely a function of the ground pressure of the machinery, amount of trafficking of the soil that takes place, and soil bearing capacity (largely related to soil wetness). The size (ground pressure exerted and its operating footprint) of the machinery is the primary agent in soil compression, but also the mode of operation (number of passes, traction and turning manoeuvres) and the care taken.

Intuitively the smaller variants of the machines exert the less pressure and are usually the better option, but they may result in more trafficking and difficulties in operation than larger units because significantly more passes are needed to achieve the same output, as sometimes can also be the case with wide tracked (low ground pressure) bulldozers.

Soils and their horizons can differ in their susceptibility to compaction depending on their 'textural class' (largely a function of their clay and organic matter contents), degree of structural development, and water retention properties.

Coarse textured mineral soil, such as sands and loamy sands, are significantly less susceptible than the finer clayey and silty soils. Peaty (>20% organic matter) and organic (8-20% organic matter) soils generally have an inherent low resilience to compaction (Askew, 2020). However, risk levels are also significantly modified by the soil water regime (Soil Wetness Class) and the local climate.

Table 2 sets out the relative inherent risk of damage to soils (when in dry/non-plastic condition) during soil handling. However, the depth to a duration of saturated soil and climate (Soil Wetness Class & Field Capacity Days, MAFF, 1988) are confounding factors where, for example, sandy soils can be at high risk where soils remain saturated at a shallow profile depth (Askew, 2020).

Soils with weakly developed structure (aggregation of particles) may be more susceptible than those which have strong more stable aggregates, and mineral soils with a high organic matter or calcium carbonate content can be more resistant to compaction, with topsoil tending to be more resilient than subsoil.

Risk to Soil Structural Damage During Handling When in a Dry Condition	Soil Texture Class (top- & subsoil)
High Resilience - Low Risk	Sand, loamy sand, sandy loam, sandy silt loam
Medium Resilience Moderate Risk (<27% clay content)	Medium silty clay loam, medium clay loam, sandy clay loam
Low Resilience High Risk (>27% clay content)	Silt loam, heavy silty clay loam, heavy clay loam, sandy clay, silty clay, clay; organic mineral, peaty soils, peat

* Based on Askew, 2020

Table 2: Simplified Inherent Risk of Soil Structural Damage Occurring within the Soil Profile Based on Soil Texture*

However, clayey soils with an apedal structure and low porosity may be less significantly affected by further compression.

Soil wetness is a major determinant of the susceptibility to compaction when trafficked by machines (Duncan & Bransden, 1986) (also see Supplementary Note 3). The differential degree of compaction between machinery combinations and handling practices is less when the soils are in dry condition. Dry soil is more resistant to compression than wet soils which have a water content at or above their plastic limit when fine (clay and silt fraction) soil particles become ‘mobile’ within compression increasing their packing density and reducing pore size and porosity. Sandy soils with a small percentage of clay size fraction/mineralogy are inherently less prone to this form of deformation compared to loamy, clayey and silty soils.

Table 3 summarises the inherent risk of compacting soils with the choice of machinery and handling practice options owing to the degree of trafficking by the machines over the surface of the soil horizons.

Soil Storage

As indicated in **Table 4**, the practice of storing (stockpiling) stripped soils in mounds (often referred to as ‘bunds’) prior to their replacement has a high risk of causing additional compaction as well as the degradation of the soil’s biological functions.

The degree of effect depends on the machinery and practice used, but also the height of the storage mound (i.e. depth of soil burial), the type (texture) and condition (wetness) of the soils, and the length of time in store (Abdul-Kareem & McRae, 1984; Johnson et al, 1988).

The best practice is to avoid soil storage by direct placing the newly stripped soils on the area to be restored. Where storage is unavoidable, it should be for the minimal time possible, unless longer term storage facilitates the direct placement of the majority of the soil.

Where possible, storage of the high-risk low resilient textural classes (see **Table 2**) should be avoided or at least minimised by limiting the height of mounds to less than 3m.

Machinery Combination & Handling Practice (see Part Two)	Dry Soil Condition	Wet Soil Condition
Excavator – Dump Truck Using Bed/Strip Practice ^{1 2} (Sheets A & D)	Low	High
Excavator – Dump Truck Using Windrow/Peninsular Practice ¹ (Sheet E)	Low/moderate	High
Bulldozer – Dump Truck Using Windrow/Peninsular Practice ^{1 2} (Sheets F & H)	Moderate* - High	High
Hybrid Excavator - Bulldozer – Dump Truck Using Modified Layer by Layer ² (Sheet K)	Moderate*	High
Bulldozer – Dump Truck Using Modified Layer by Layer Practice ^{1 2} (Sheets I & J)	Moderate* - High	High

* With Low Ground Pressure Bulldozers; ¹ = soil stripping; ² = soil replacement

Table 3: Relative Risk of Significant Compaction During Soil Stripping & Replacement

It has become standard practice for topsoil mounds to be restricted to a maximum height of 3m and 5m for subsoils (Natural England, 2021). Where single mounds have different soil types, they should be kept separated by geotextile or other suitable means. In the case of particularly large mounds with long storage durations, it may be acceptable for the subsoil to be covered with a layer of topsoil to its natural depth and utilised for landscape, agricultural or amenity purposes.

The above should be taken into account in the SRMP by the professional soil advisor.

Efficacy of Soil Recovery - Variable Soils and Mixing

Table 5 summarises the inherent efficacy of recovering the soil resources according to the choice of machinery and handling practice options. This is related to the ease of ability to see and react to changes in soil type and thickness of soil horizons (i.e., patterned ground), and the relative risk of soil horizon mixing due to trafficking (see Supplementary Note 5).

Relative Susceptibility to Rainfall Delays

The inherent susceptibility of the operations to significant programme delays following rainfall events due to extensive exposed soil surfaces during soil stripping and soil replacement in the absence of a vegetation cover is summarised in Table 6.

Smearing of the exposed surface of the soil (known as ‘soil sealing’) using a bulldozer blade or excavator bucket to reduce water infiltration is a temporary action widely practiced. It is deployed where soil surfaces are likely to be exposed to rainfall events and when soil handling has been suspended. However, this is likely to require remedial decompaction/cultivation measures on the resumption of operations.

The better practice, and that given in the guidance in Part Two, is to ensure bare soil surfaces are not exposed to rain events. However, in doing so it is imperative that the completed soil surfaces are cultivated, seeded or planted without delay and before the onset of prolonged wet conditions.

Machinery Combination & Handling Practice (see Part Two)	Direct Placement	Storage in Single Tier Low Mounds	Storage in Multi-Tier Mounds
Excavator – Dump Truck Using Bed/Strip Practice ^{1 2} (Sheets A & D)	Low	Moderate	High
Excavator – Dump Truck Using Windrow/Peninsular Practice ¹ (Sheet E)	Low/moderate	Moderate	High
Bulldozer – Dump Truck Using Windrow/Peninsular Practice ^{1 2} (Sheets F & H)	Moderate* - High	Moderate* - High	High
Hybrid Excavator - Bulldozer – Dump Truck Using Modified Layer by Layer ² (Sheet K)	Moderate*	Moderate*	High
Bulldozer – Dump Truck Using Modified Layer by Layer Practice ^{1 2} (Sheets I & J)	Moderate* - High	Moderate* - High	High

* With Low Ground Pressure Bulldozers; ¹ = soil stripping; ² = soil replacement

Table 4: Relative Risk of Significant Compaction of Stored Soils

Machinery Combination & Handling Practice (see Part Two)	Reactive to Changes in soil type, thickness, patterned ground	Risk of Soil Horizon Mixing
Excavator – Dump Truck Using Bed/Strip Practice ^{1 2} (Sheets A & D)	High	Low
Excavator – Dump Truck Using Windrow/Peninsular Practice ¹ (Sheet E)	High	Low
Bulldozer – Dump Truck Using Windrow/Peninsular Practice ^{1 2} (Sheets F & H)	Low	High
Hybrid Excavator - Bulldozer – Dump Truck Using Modified Layer by Layer ² (Sheet K)	High/Low	Low/High
Bulldozer – Dump Truck Using Modified Layer by Layer Practice ^{1 2} (Sheets I & J)	Low	High

¹ = soil stripping; ² = soil replacement

Table 5: Reactiveness to Changes in Soil Characteristics & Risk Soil Horizon Mixing

Further information on the geographic based risk of seasonally wet soil conditions is given in the Supplementary Note 4, which also includes an established protocol for the stoppage and restart of operations due to rainfall events (according to the duration and intensity of rainfall events).

The Deployment of Earth-moving Machinery & Handling Practices

Whilst all combinations of earth-moving machinery and handling practices could be used to strip, store and replace soil material, as demonstrated above, there are inherent differences in the degree of risk for the delivery of the intended after uses, and soil functioning and ecosystem services according to the choice made. This is primarily due to the degree of significant compaction affecting the ability of the replaced soil profile to function in the required manner, but also ones of risk of programme delays due to weather and poorer efficacy in soil resource recovery.

In terms of soil textural class, the minimal information that should be available for all schemes, simplistic choices can be made according to the relative resilience to compaction of damaging soil structure (Table 7).

For the reasons set out above, the excavator-dump truck combination and bed/strip practice (Part Two, Sheets A & D) has the lowest risk of all the options and is the most suitable for all soil texture resilience categories. Because of higher intrinsic risk due to greater trafficking of machines on the soil surfaces the windrow handling practices, using either excavators (Sheet E), low ground pressure bulldozers (Sheets F & H) or the 'hybrid' excavator-bulldozer combination (Sheet K), restricts their suitability to soils of a moderate and high resilience. However, this level of risk in using the bulldozer combination is dependent on the soils being and remaining in a dry condition throughout the soil profile being handled and for the duration of the work.

In England and Wales where agricultural land is to be stripped of its soils and the after use is to be for agricultural production, it too is a factor in the choice of machinery and practices. To achieve sustainable agricultural production, maintain flexibility in the land use and resilience to climate change, the soil resources and their functional attributes on reclamation are to be conserved as much as possible. In the past a distinction was sometimes made between Agricultural Land Quality Grades

Machinery Combination & Handling Practice (see Part Two)	Ability to Maintain Transpiring Vegetation Cover for Soil Stripping	Ability to Progressively Establish Vegetation Cover on soil Replacement	Inherent Risk of Delay in Operations for Soil Stripping/Replacement
Excavator – Dump Truck Using Bed/Strip Practice ^{1 2} (Sheets A & D)	High	High	Low/Low
Excavator – Dump Truck Using Windrow/Peninsular Practice ¹ (Sheet E)	High	NA	Low/NA
Bulldozer – Dump Truck Using Windrow/Peninsular Practice ^{1 2} (Sheets F & H)	High	Low	Low/High
Hybrid Excavator - Bulldozer – Dump Truck Using Modified Layer by Layer ² (Sheet K)	High	High	Low/Low
Bulldozer – Dump Truck Using Modified Layer by Layer Practice ^{1 2} (Sheets I & J)	High	High	Low/Low

¹ = soil stripping; ² = soil replacement

Table 6: Inherent Risk in Operational Delays Due to the Ability to Maintain and Quickly Establish a Vegetation Cover

Soil Texture Inherent resilience of Soil See Table 1	Machinery & Handling Practice (assuming soils are in dry/non-plastic condition and not stored)		
	Increasing Risk of Soil Compaction ->		
High Resilience - Low Risk	ExDt-Bed ^{1 2}	ExDt-Wind ¹ / Hybrid-Wind ²	BuDt-Wind ^{1 2} / BuDt-Mod Layer ^{1 2}
Medium Resilience - Moderate Risk	ExDt-Bed ^{1 2}	ExDt-Wind ¹ / Hybrid-Wind ²	
Low Resilience – High Risk	ExDt-Bed ^{1 2}		

Key: Machinery Combinations & Soil Handling Practices (also see Part Two):

¹ = soil stripping; ² = soil replacement

ExDt-Bed = Excavator – Dump Truck using Bed/Strip Practice (Sheets A & D)

ExDt-Wind = Excavator – Dump Truck using Windrow/Peninsular Practice (Sheet E)

BuDt-Wind = Low ground pressure Bulldozer – Dump Truck using Windrow/Peninsular Practice (Sheets F & H)

BuDt-Layer = Low ground pressure Bulldozer – Dump Truck using Modified Layer by Layer Practice (Sheets I & J)

Hybrid-Layer = Excavator for subsoil & Low ground pressure Bulldozer for topsoil – Dump Truck using Modified Layer by Layer Practice (Sheet K)

Table 7: Most I kely suitable machinery & soil handling practice

1, 2 & 3a (i.e. Best & Most Versatile (BMV), MAFF, 1988) and 3b, 4 & 5 (i.e. non-BMV) as to which standard of restoration was applied (Paragraphs 3.1 & 3.2, Schedule 5, Town & Countryside Planning Act 1990, UK Government 2021b).

Current government policy is that all reclamation (restoration and aftercare) agricultural schemes should be to high standards. For agricultural after uses, the best available practice (i.e. least risk) is using the excavator-dump truck combination in conjunction with the bed system (Sheets A – D) which should be used wherever possible irrespective of land quality (Welsh Assembly Government, 2004). With the anticipated effects of climate change on soils (Keay et al, 2013; Welsh Government, 2020), it is important the soil resource per se is conserved whatever its quality grading because of the range of ecosystem services it might provide in addition to agricultural production, for example water storage, flood mitigation, carbon storage and greenhouse gas regulation etc. Where alternative options are proposed for agricultural land, the reasons need to be justified and agreed with the planning authority and the statutory advisors (Natural England & Welsh Government), along with any remedial measures to be in place, and set out in the Soil Resource & Management Plan.

Justifications might include constraints on the safe operation of machinery (eg gradient, complex topography), soil profile attributes (e.g. shallow profile, excessive stoniness, massive apedal soil structure).

For forestry and woodland, in the recent past there have been strong recommendations for the use of excavators and dump trucks in site reclamation (Moffat & Bending, 2006; Moffat, 2014). Hence, it is recommended that the general use of excavators and dump trucks deploying the bed system of soil stripping and replacing (Sheets A - D) woodland soils is adopted in preference to others. Where alternative options are proposed for forestry/ woodland, the reasons need to be justified and agreed with the planning authority with advice from the statutory advisors (Forestry Commission, Natural England & Welsh Government) as

appropriate, along with any remedial measures to be in place, and set out in the Soil Resource & Management Plan.

Except for BMV land, there are no current policy expectations for reclamation to non-agricultural land, such as amenity, biodiversity and habitat recreation schemes (Bradley et al, 2006) and the machinery and handling practices to be deployed. For non-agricultural after-uses on lower quality land, it is recommended that the selection is based upon the soil texture/resilience model set out above in **Table 2**, and as appropriate, the more refined version of Askew (2020). The reasons for the selection along with any remedial measures to be in place should still be justified and need to be agreed with the planning authority and the statutory advisors (as appropriate). These should be set out in the Soil Resource & Management Plan. For BMV soils that are to be reclaimed for non-agricultural uses, the expectation is that the soils will be restored to their former capability (ALC Grade) (Paragraph 040, UK Government, 2014).

Remedial Treatment of Compaction

Where there is a risk of significant compaction occurring through the choice of machinery/handling option deployed and/or soils have been handled in sub-optimal wetness conditions there will be reliance on subsequent remedial treatment to achieve the intended after use and services.

Many former mineral workings have been backfilled with inert waste. Remedial treatments of the infill, by digging or ripping, may not be advisable where these are not to be part of the replaced soil profile, and this should be covered in the SRMP. There may also be 'capping layers', required by the Environment Agency and Natural Resources Wales, which must not be disturbed. The treatment of former silt-lagoons needs particular careful consideration and consultation with a geotechnical specialist where there is a possibility of breaking through a dewatered and stabilised upper material into the saturated underlying lower material.

Two commonly used methods for remedying compaction caused are the use of tines drawn through the soil layer (often referred to as 'ripping')

or digging using an excavator bucket (Sheets N & O). Their effectiveness is dependent on the tools reaching the compacted layer within the process of the replacement of soils. Hence, the use of standard agricultural ploughing and subsoiling methods are largely limited to the topsoil layer in their application and efficacy during the soil replacement process. What is needed is specialist equipment of the SIMBA bespoke types (SIMBA, 1983).

The actions of ripping and digging serve to break down the compacted soil mass into smaller lumps creating air spaces between them and/or creating fissures (planes of weakness and cracks). They do not result in the enlargement of the compressed larger soil pores per se which is a matter of soil development processes, such as swelling and shrinkage in clayey soils with changes in water content, plant root penetration and microbial activity over a long period of time.

However, the physical cultivation of compacted layers can facilitate these, although its effectiveness may be short lived and less effective than minimising the degree of compaction in the first place through the choice of more appropriate machinery and handling practice.

The effectiveness of both methods (Sheets N & O) are dependent on the soil being in a dry condition in order to be able to 'shatter', thereby creating small lumps of soil and planes of weakness. Soils in a wet (plastic state), particularly those of a finer textured low and moderate resilience (see **Table 2** above), will simply deform and smear around the tines and compress further within the bucket exacerbating the compaction condition. Hence, where the choice of machinery and practice is to rely upon the effectiveness of decompaction to achieve the after use and ecosystem services, the re-laid soils need to be in a dry condition at the time of stripping and storage, and during relaying. Where this is not the case, progressive and costly remedial work over a number of years will have to be relied upon during the aftercare period and beyond when transpiring vegetation can be grown to assist with the drying of the soil profile to facilitate soil decompaction.

Model methods are provided in **Part Two**, Sheets N & O of the guidance for the use of tines and digging with buckets, and their integration into the process of soil replacement. This should be clearly set out in the SRMP as it is often overlooked and is essential if compaction is to be reduced during the reinstatement of the site, particularly when it is at depth and is the only opportunity to do so.

The following sets out the basic options where decompaction, involving a final profile comprising a basal layer, subsoil and topsoil layers, may be needed to achieve the intended after use and ecosystem services:

Option 1: is where the basal layer needs to be treated but is left until the subsoil is placed when both are decompacted together, followed by the decompaction of the topsoil and subsoil layers together (and basal layer) using tines that are long enough. This option is not suited to digging where the soil horizons would be mixed.

Option 2: is where each layer is treated separately by either tines or digging.

Option 3: is where the basal layer is treated or left untreated, followed by the placement of the subsoil and topsoil layers, which are to be decompacted by the use of tines. In the case of deep horizons this option can be limited by the capability of the machinery, the tines or bucket used. This option is not suited to digging where the soil horizons would be mixed.

Removal of Stones and Non-soil Debris

The need for the removal of stones of a particular size and non-soil debris (such as concrete slabs, tree stumps or wire rope) from the reinstated soil profile or from the interface with inert fill may be necessary to facilitate effective decompaction work and enable agricultural tillage operations to take place, as well as to achieve the required standard of reclamation, the intended after use, and provision of ecosystem services. For imported soils (where there is a shortfall), screening may be an option and cost effective.

The options for removal within the placed soil

are limited by where the stone and debris occur. Generally, each affected soil layer will need to be treated separately. This will also determine the options for the treatment of compaction, although the removal operation may also serve at the same time to reduce compaction. Guidance on the deployment of the available methods are given in **Part Two** Sheets L & M. The provisions for this should be set out in the SRMP along with the method to be used, the criteria to be used (eg stone size), along with its operational integration into the soil replacement process.

Cultivations Following Soil Replacement

Additional cultivations may be necessary (such as the creation of a seedbed and reduction in the surface stoniness) following the replacement of the soil profile and completion of remedial works for decompaction and stone/artefact removal. It is expected that these would be of a type relevant to the after use. The specification for these is outside of the scope of this guidance but should be covered in the SRMP. The timing of these finishing cultivations is critical as the replaced soils will be vulnerable to compaction by the trafficking of the machines used, particularly if rainfall events cause the soil to become wet. Importantly, these operations should be undertaken progressively as soon as the replaced topsoil is laid.

The finishing cultivations required following soil replacement are likely to differ between the earth-moving machinery combinations used. With the excavator option and friable soils (Sheet N), the bucket may be sufficient with or without the use of a stone-rake attachment (Sheet L). Where the soil clods to be broken down are too hard, the use of disc or 'crumbler bar' cultivation tools may be necessary. For the bulldozer combinations, secondary treatment by discing is the most likely.

Under-Drainage

Guidance on the installation of under-drainage is outside of the scope of **Part Two**. Where under-drainage needs to be installed, this usually takes place during years 1 or 2 during the aftercare period following any settlement of the replaced soil profile. There have been schemes that have installed under-drainage progressively using the

'bed/strip' system of soil replacement (Sheet D), however, this may be less satisfactory than the conventional approach. On the other hand, subsequent installation can result in the disruption and compaction of the reinstated soil profiles if undertaken without care and when the soil profile is wet, as often occurs.

Vegetation Cover

It is important for a vegetation cover to be established as soon as possible and in sufficient time before the growing season ends to protect the soil surface and minimise slaking of the loosened soil profile, attenuate surface runoff and to initiate soil recovery processes. The extent of soil replacement should not usually exceed the capability of establishing an effective vegetation cover. It should be undertaken progressively as soon as the replacement operations and final cultivations are completed to avoid the soil surface remaining bare and unprotected by vegetation over the winter with the high risk of loss of soil from wind and water erosion, and the infestation by weeds. Where the earlier than expected deterioration of weather conditions prevent proper preparation the sowing of a temporary (sacrificial) quickly establishing grass cover may be an option. In unavoidable circumstances alternative seeding methods can be deployed, including hydro-seeding and aerial seeding.

Other measures include the installation of cut-off grips and use of biodegradable geotextiles. Where these measures are deployed further remedial treatments may be necessary when operations are undertaken to establish the intended vegetation. Again, all these provisions should be covered in the SRMP.

References

- Abdul-Kareem A W & McRae S G, 1984. The effects on topsoil of long-term storage in stockpiles. *Plant and Soil*, 76, 357–363.
- Askew R, 2020. Chapter 7 – Environmental Topics: 7.4 Soils, pp 119-123. In B Carroll, J Fothergill, J Murphy & T Turpin (eds), *Environmental Impact Assessment Handbook: A practical guide for planners, developers and communities*, 3rd edition. ICE Publishing, London.
- [Bacon A R & Humphries R N. 1987. Deep ripping: A more effective and flexible method for achieving loose soil profiles. In Rainbow, A K M \(ed\). *Advances in Mining Science & Technology 2: Reclamation, Treatment and Utilisation of Coal Mining Wastes*. Elsevier, Amsterdam pp 321-330](#)
- Ball B C & Munkholm L J, 2015. *Visual Soil Evaluation: Realizing crop production with minimum environmental impact*. CABI, Wallingford.
- [Ball B C, Guimarães R M L, Cloy J M, Hargreaves P R, Shepherd T G & McKenzie BM, 2017. Visual soil evaluation: A summary of some applications and potential developments for agriculture. *Soil and Tillage Research*, 173, 114-124](#)
- Bending N A D, McRae S G & Moffat A J, 1999. Soil-forming materials: their use in land reclamation. Department of the Environment, Transport and the Regions. The Stationery Office, London.
- Bradley I, Clarke M, Cooke H, Harris J, Leeds-Harrison P, Mayr T, Towers W, Rodwell J & Gowing D, 2006. Research Report Number 712: Guidance on understanding and managing soils for habitat restoration projects. English Nature, Peterborough.
- [Bransden B E. 1991. Soil protection as a component of gravel raising. *Soil Use and Management*, 7, 3, pp 139-144](#)
- [British Society of Soil Science. Undated. Working with soils series: Professional competency in soil science](#)
- [British Society of Soil Science. 2021. Guidance Document 3 – Working with soil Guidance Note: Benefitting from soil management in development and construction](#)
- [Department of the Environment. 1989. Minerals Planning Guidance 7: Restoration of Mineral Workings \(paragraph 2\)](#)
- [Department of Environment, Food & Rural Affairs. 2005. Guidance for the Successful Reclamation of Mineral and Waste Sites](#)
- [Department of Environment, Food & Rural Affairs. 2009a. Safeguarding Our Soils: A strategy for England](#)
- [Department of Environment, Food & Rural Affairs. 2009b. Construction Code of Practice for the Sustainable Use of Soils on Construction Sites](#)
- [Duncan N A and Bransden B E. 1986. The effects on a restored soil caused by soil moving under different moisture contents. *Applied Geography*, 6, 3, pp 267-273](#)
- Dunker R E, Barnhisel R I & Darmody R G (eds), 1992. *Proceedings of the 1992 National Symposium on Prime Farmland Reclamation*. University of Illinois at Urbana-Champaign, Illinois.
- [Humphries R N, Close, P & Smallshaw R J. 2018. The Selection and Operation of Earth Moving Equipment for the Rehabilitation of Functional Soil Profiles: An updating of the UK guidance. *Journal American Society of Mining and Reclamation*, 2018 Volume 7, Issue 2 pp 1-18](#)
- Humphries R N, Thompson R J K & Heames M D, 2019. Case Study: Appraisal of four soil-based metrics in the establishment of sustainable upland grassland at a mine site in South Wales, United Kingdom. *Journal American Society of Mining and Reclamation*, 8, 3, 1 – 21.
- Johnson D B, Williamson J C & Bailey A J, 1988. 95-109. Response of soil micro-organisms to stockpiling and land restoration, pp 95-109. In, *Land Restoration Investigation and Techniques*. British Opencast Executive, Mansfield.
- Keay C A, Jones R J A, Procter C, Chapman V, Barrie I, Nias, I, Smith S & Astbury S, 2013. Research contract SP1104: The Impact of climate change on the capability of land for agriculture as defined by the Agricultural Land Classification, DEFRA, London.
- MAFF, 1982. Reference Book 441: Techniques for measuring soil physical properties. Her Majesty's Stationery Office, London
- [MAFF. 1988. Agricultural Land Classification of England and Wales](#)
- Moffat A, 2014 Forest Research BPG Note 4: Loose Tipping. Forestry Commission, Farnham.
- Moffat A J & Bending N A D, 2006. Replacement of soil and soil forming materials by loose tipping in reclamation to woodland. *Soil Use and Management*, 16, 2, 75-81.
- [Natural England. 2021. Planning and aftercare advice for reclaiming land to agricultural use](#)
- Reeve M J, 1994. Improving land restoration in Britain by better timing of soil movement, pp 28-37. In, *Proceedings American Society of Mining and Reclamation*. DOI:10.21000/JASMR94030028
- Reeve M J, Heaven F W & Duncan N A, 2000. Evaluation of Mineral Sites Restored to Agriculture. Report 313/50 to the Ministry of Agriculture Fisheries and Food, London.
- SIMBA, 1983. *Handbook for the Operation of Restoration*

Implements. National Coal Board – Opencast Executive, Mansfield.

Spoor G, 2006. Alleviation of soil compaction: requirements, equipment and techniques. *Soil Use and Management*, 22, 2, 113-122.

Spoor G and Foot K J, 1998. Soil compaction alleviation on restored sites. Pp 277 – 286. In, H R Fox, H M Moore & A D McIntosh (eds), *Land Reclamation: Achieving Sustainable Benefits*. A A Balkema, Rotterdam.

[SRUC, 2021. Visual Evaluation of Soil Structure](#)

[UK Government, 2014. Minerals Planning Practice Guidance: Guidance on the planning for mineral extraction in plan making and the application process](#)

[UK Government, 2020a. Health & Safety at Work Act 1974](#)

[UK Government, 2020b. The Quarry Regulations 1999](#)

[UK Government, 2020c. Enabling a Natural Capital Approach \(ENCA\): Guidance](#)

[UK Government, 2020d. Town and Country Planning Act 1990](#)

[UK Government, 2021a. Statutory Instruments 2016: No. 127 - The Wildlife and Countryside Act 1981 \(England and Wales\) \(Amendment\) Regulations 2016](#)

[UK Government, 2021b. Town and Countryside Act 1990](#)

[Welsh Assembly Government, 2004. Planning Policy \(Wales\) - Minerals Technical Advice Note 1: Aggregates - Annex B4: Handling of Soils during Mineral Operations](#)

[Welsh Government, 2020. Capability, Suitability & Climate Programme: Effect of Climate Change on the predictive ALC map of Wales v2](#)

[Wikipedia, 2020. Natural Capital](#)

SUPPLEMENTARY NOTES

Supplementary Note 1

Soils

The starting point in determining the appropriate soil handling strategy and method for the reclamation of particular land uses and soil-based ecosystem services is the description of the original and proposed soil profiles. This information can help to identify the practicability of after uses at the outset when designing a reclamation scheme, whether it is a replication of the original or a novel profile for the intended after use, soil function and environmental and ecosystem service provisions. The same applies when assessing the restoration achievement against the original pre-working soil characteristics.

Soil is the surface covering layer which provides for the land use and ecosystem services such as vegetation cover, food production, and water run-off attenuation. The soil layer can be mineral and/or organic matter in its origin and nature. Soils vary spatially in their functional attributes and capacity depending on the parent material, geological and fluvial processes, time, climatic conditions, and land use history.

Simplistically, the idealised soil is differentiated vertically in profile (see **Figure 1.1**) into distinct or graduated layers (Hodgson, 1997). The upper vegetated 'A' horizon, in soil science terms referred to as the 'topsoil', being the most biologically active with accumulated humified organic matter and is often structurally well developed. The underlying layer(s) 'E' and/or 'B' horizon 'subsoil' layer(s) are often chemically altered parent material. They are less biologically active and structurally developed. The underlying 'C' horizon, from which mineral topsoil and subsoil may have developed, is usually less altered, structured and biologically active, but may be an important part of the functioning soil profile. This layer and underlying unaltered drift/solid geology (if present) lying above the economic mineral layer is usually termed 'overburden' and handled differently from the soil resource as a bulk material to be removed/replaced according to civil engineering practice.

However, in some cases the overburden is of a character that it can be used as substitute soil material (soil forming material, Bending et al, 1999) particularly where there is a historic shortfall because previous land development. In some instances, particularly river terrace sand/gravel deposits, the B and/or C horizons may be considered to be part of the economic mineral deposit and if used a substitute for the lost soil horizons may need to be found. Wherever possible, the supplementary/substitute soil forming material should be treated during handling as if it were a subsoil material.

Beware the use of the terms Topsoil and Subsoil in civil engineering for the geotechnical description of soils is different from that used in soil science and are not inter-changeable.

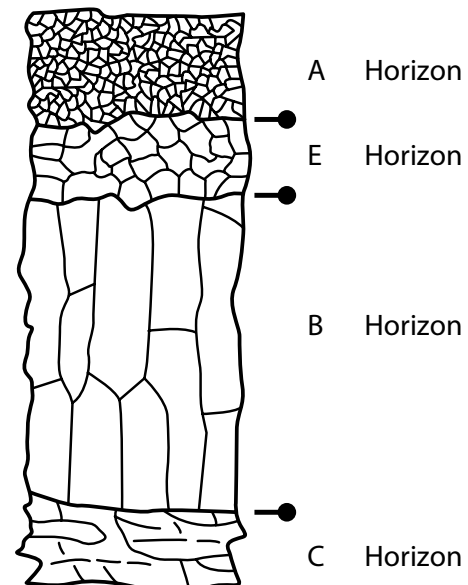

Figure 1.1: An idealised soil profile

Naturally occurring soil profiles in England and Wales have been described in detail and formally classified as to their origin, soil forming processes and functional characteristics (Soil Survey of England & Wales, 1984). Whilst the different soils of the UK have been mapped (some examples are illustrated in **Figure 1.2**), this is usually of not sufficient local detail for devising Soil Resource & Management Plans and operational purposes. Hence, site specific surveys are to be undertaken by qualified soil surveyors (British Society of Soil Science, Undated).

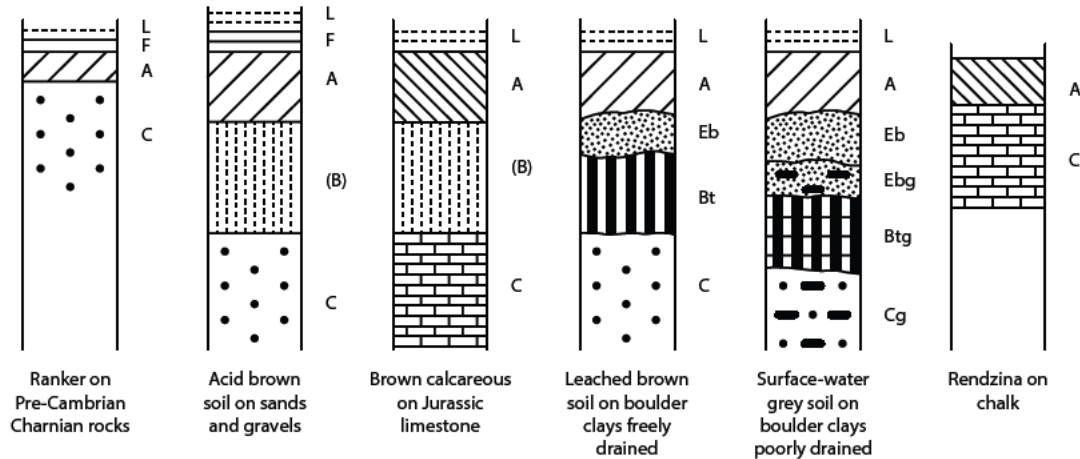

Figure 1.2: Some examples of the variation in soil profiles (L & F surface accumulated organic matter; A = topsoil B&E = subsoil horizons C = 'parent' material)

The soil information to be collected to help inform the landscape plan and reclamation strategy is usually from profiles of up to 1.2m deep (Natural England, 2021). It may include the upper part of the workable mineral or may even be deeper depending on circumstances such as where peat deposits occur. Importantly, the different soil characteristics and functions of the soil horizons within the profile and the underlying material need to be recorded.

Whilst most of the information may be collected during agricultural land quality assessments and can be used without the duplication of effort, more intensive sampling may be needed where there are substantial lateral and vertical variations in soil distribution and where boundaries between soil types need to be defined.

Additional data on soil pH, nutrient status, and organic matter content as both a record of baseline conditions, and for scheme design, such as the identification and management of soils for biodiversity-led after use where, for example lower nutrient topsoils or those soils with a particular pH range may require identification.

Standard field soil survey methods and descriptions should be used (Hodgson, 1997) to include thicknesses of recognisable soil development layers (soil horizons), for which texture and aggregate structure, porosity and size of pores, stoniness and stone sizes, the distribution and rootable depth

of plant roots, colour and staining/deposits, and biological activity (Figure 1.3). From these the available water capacity can be estimated as well as the depth to slowly permeable layers can be identified and the Soil Wetness Class assigned (MAFF, 1988). Free-calcium carbonate and soil reaction (pH) and salinity can be determined in the field. Supplementary laboratory determinations may be required for soil organic matter, particle size determinations. Other factors such as gradient, patterned ground and climate will influence current and future potential land use and ecosystem services.

The collection and interpretation of the local circumstances and soil information requires skill and is to be done by experienced soil surveyors. They are able to define the topsoil, subsoil and drift/solid geology layers for the purpose of soil stripping, storage and replacement, and the inherent limitations or qualities for the intended land use and ecosystem services.

The most useful characterisation of soils for the practical purpose of determining their resilience and susceptibility to compaction and the resulting consequences are those of mineral particle size classification (textural) and organic matter content groupings (Figure 1.4). Soils with an organic matter content of over 20-25% (depending on clay content) are referred to as 'organic' or 'peaty' and are differentiated from 'organic mineral' soils with

Grid Ref										Proj No										9 8 7 6 5 4 3 2																																																																																									
Sub group										Series										Var										Slope										Slope shape										Date										Observer																																																	
Land use										Vegetation										Community QV										Spare																																																																															
Depth										PSC/Peat										Matrix										v c										Mottle 1										v c										Ab										Stone										Other										Abund																			
Horizon										Hum										CaCO ₃										Mottle 2										v c										Ab										Type										Subtype										Grain size mm										Rk										Fe/Mn Jar									
Depth										PSC/Peat										Matrix										v c										Mottle 1										v c										Ab										Stone										Other										Abund																			
Horizon										Hum										CaCO ₃										Mottle 2										v c										Ab										Type										Subtype										Grain size mm										Rk										Fe/Mn Jar									
Depth										PSC/Peat										Matrix										v c										Mottle 1										v c										Ab										Stone										Other										Abund																			
Horizon										Hum										CaCO ₃										Mottle 2										v c										Ab										Type										Subtype										Grain size mm										Rk										Fe/Mn Jar									

0 = None F = Few C = Common M = Many A = Abundant (not conchl; not mottles) V = Very Many (not stones) X = Extr. Abund (not mottles)
 VS = Very Small S = Small M = Medium L = Large VL = Very Large B = Boulders

Figure 1.3: Example of soil profile recording card

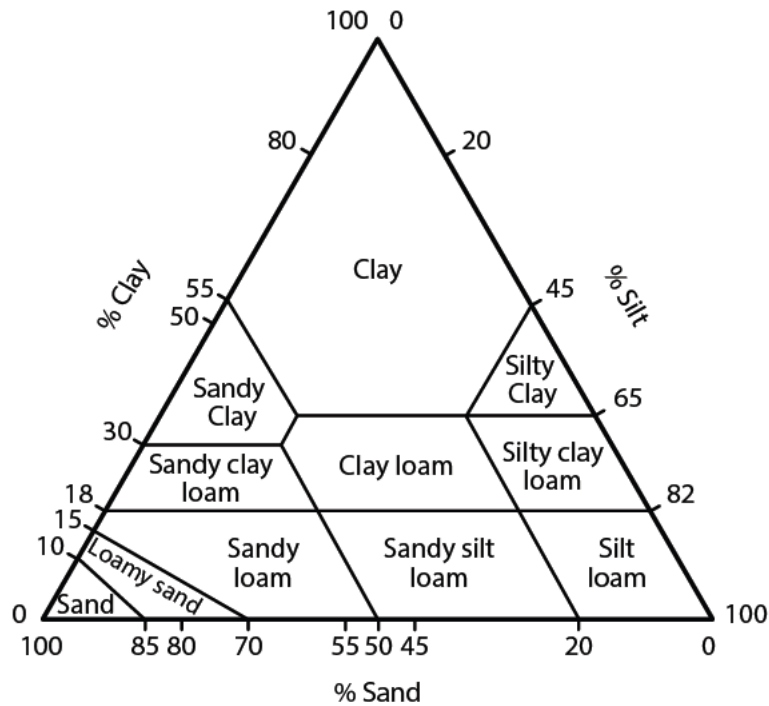

Figure 1.4: Soil mineral particle size (texture) classes

a content of between 6-20% or 10-25%, whereas 'Mineral' soils have a content lower than 6-10% (Natural England, 2008).

Mineral soils are categorised into 11 main particle-size classes according to the proportion of sand, silt and clay sized mineral particles. Sands are further divided into fine, medium, and coarse fractions.

In terms of resilience and susceptibility to compaction, the clay content of the soil largely determines the change from a solid to a plastic state (the water content at which this occurs is called the 'plastic limit' (MAFF, 1982)). This is the point at which increasing soil wetness has reduced the cohesion and shear strength of the soil.

Sands, gravel and peat do not exhibit plasticity and have no plastic limit, silts only occasionally, whereas clay materials possess a high degree of plasticity. Mineral soil textures can be grouped, according to clay content (Reeve, 1994), to represent a descending hierarchy of risk from most to least:

- Soils <10% clay particle size fraction – sand class (often referred to as 'very light soils') – most resilient & least susceptible
- Soils 10-18% clay particle size fraction – loamy sand, sandy loam, sandy silt loam, silt loam classes (often referred to as 'light soils')
- Soils 18-27% clay particle size fraction – sandy clay loam, clay loam, silty clay loam classes (often referred to as 'medium soils')
- Soils >27% clay particle size fraction – sandy clay, clay loam, silty clay, clay classes (often referred to as 'heavy soils') – least resilient and most susceptible.

Askew (2020) sets out a similar soil texture categorisation of risk (resilience), this is reproduced in a simplified form in **Part 1, Table 1**.

The relative potential of the soil groupings to be in a plastic state when sufficiently wet is a significant consideration in the timing of handling of soils and in the need for remedial treatment. Soil wetness is a function of climate (especially rainfall and evapo-transpiration), soil (texture, structure, porosity, organic matter content), and site conditions such as

gradient and landform, flood risk and groundwater conditions. Indicative soil textures (top- and subsoil) and likely ranges in Soil Wetness Classes for England and Wales are shown on the National Soil Resource Institute's LandIS web pages (National Soil Resources Institute, 2020); also see Supplementary Note 4 for more about soil wetness.

References

Bending N A D, McRae S G & Moffat A J, 1999. Soil-forming materials: their use in land reclamation. Department of the Environment, Transport and the Regions. The Stationery Office, London.

[British Society of Soil Science, Undated. Working with soils series: Professional competency in soil science](#)

Hodgson J M, 1997. Soil survey field handbook: describing and sampling soil profiles. 3rd Edition. Soil Survey and Land Research Centre, Silsoe, Cranfield University.

MAFF, 1982. Reference Book 441: Techniques for measuring soil physical properties. Her Majesty's Stationery Office, London

[National Soil Resources Institute, 2020. LandIS: The Land Information System](#)

[Natural England, 2008. Soil texture \(TIN037\)](#)

[Natural England, 2021. Planning and aftercare advice for reclaiming land to agricultural use](#)

Soil Survey of England & Wales, 1984. Soils and their Use. Bulletins 10 – 15. SSEW, Harpenden.

Supplementary Note 2 Soil Resource & Management Plan

As soils are important Natural Capital providing a range of essential environmental and ecosystem services (UK Government, 2020), a Soil Resource & Management Plan (SRMP) is likely to be required for most planning consents for mineral developments (DEFRA, 2005; UK Government, 2014; British Society of Soil Science, 2021c; Natural England, 2021).

The purpose of the SRMP is to ensure the soil capital is clearly identified as a pre-working baseline, not unduly degraded or lost and that the after uses are sustainable and sufficiently resilient. Without an appropriate SRMP there is a risk of losing, damaging or contaminating the soil resource, and failure to identify opportunities and constraints for site working and reclamation design at the outset.

The SRMP should normally be prepared to support a planning application for mineral extraction, for example as part of an environmental statement. The detail within the SRMP will vary between mineral sites and their context and is to be agreed prior to determination with the Mineral Planning Authority with advice from their statutory advisors Natural England, Welsh Government and the Forestry Commission. Early consultation as part of the pre-application process is advisable. The approved SRMP should be a condition of the planning consent and considered as a 'live' document that is reviewed and updated periodically as appropriate during the operational development and reclamation (restoration and aftercare) of the scheme.

The scope of the information to be needed is set by Natural England (2021) in their Planning and Aftercare Advice for Reclaiming Land to Agriculture. It can be used as a basis for other land uses and reclamation schemes. The now archived DEFRA (2004) Guidance for Successful Reclamation of Mineral and Waste Sites also provides useful checklists.

The British Society of Soil Science (2021a & 2021b) also provides guidance on the background and

field collection of soil and related climatic data as does the National Soil Resources Institute's (2020) information system.

References

[British Society of Soil Science, 2021a. Soils and Land Quality: Microsoft Word - Soils and Land Quality - July 2021.docx](#)

[British Society of Soil Science, 2021b. Guidance Document 1: Working with soil guidance note on assessing agricultural land classification surveys in England and Wales](#)

[British Society of Soil Science, 2021c. Guidance Document 3 – Working with soil Guidance Note: Benefitting from soil management in development and construction](#)

[DEFRA, 2005. Defra Guidance for Successful Reclamation of Mineral and Waste Sites](#)

[Defra, 2020. Enabling a Natural Capital Approach Guidance](#)

[National Soil Resources Institute, 2020. LandIS: The Land Information System](#)

[Natural England, 2021. Planning and aftercare advice for reclaiming land to agricultural use](#)

[UK Government, 2014. Minerals Guidance: Restoration and aftercare of minerals sites, paragraph 040](#)

Supplementary Note 3 Soil Compaction

Soil compaction is the term used to describe a condition where the soil particles have been compressed tightly together to give a higher packing density/bulk density (**Table 3.1**) than would be expected for the soil-type or particular horizon within the soil profile (Hodgson, 1997). Soil density has a profound effect on the drainage and aeration of soils, and hence on plant root growth and soil ecology, soil structural development, and overall functioning, including greenhouse gas emissions.

Soil types differ in their inherent packing density, but also within their profiles, with the upper horizons having lower densities than their lower horizons because of a greater porosity. Compression can reduce the porosity and pore size resulting in an increase in volumetric density and hence soil strength. The increase can significantly reduce plant root growth and/or soil infiltration/drainage and aeration, thereby reducing productivity and the recovery of soil function after soil handling, besides causing waterlogging and increasing runoff.

Compaction is typically caused when soils are traversed by heavy machinery or trampled by livestock, but also in the handling (stripping, stockpiling and transporting) of soils. Soils are generally most susceptible to compaction in a wet condition when soil strength and resistance to compression are at their lowest (see Supplementary Note 4).

The potential for compacted soils to occur in restored mineral workings is particularly high and can inhibit the achievement of the planned land use and provision of the intended ecosystem services. In some circumstances, like the modification of drainage characteristics for some wetland creation schemes, here compaction within the soil profile or underlying material for a higher density/lower porosity can be beneficial.

The packing density of soils is a useful indicator of soil strength and its relative compaction (Hodgson, 1997; Ball & Munkholm, 2015; Ball et al, 2017). Alternatively, penetrometers can be used to measure soil strength (MAFF, 1982), although their interpretation can be confounded by a number of soil factors such as its water content and stoniness.

Packing Density Category~	Indicative Bulk Density (g/cm ³)~
Low* – single grain loose when moist / weak strength when moist	<1.40
Medium – moderately firm with many macropores	1.40 – 1.75
High – single grain compact / firm to strong strength with few macropores#	>1.75

~ see Hodgson (1997); *rare in clay & sandy clay mineral soils; # rare in mineral topsoils unless clay/clay loam mineral soils, also rare in organic minerals soils & peat

Table 3.1: Packing Density Categories and Corresponding Typical Bulk Densities in Mineral Soils

Bulk density measurements are more accurate, and whilst requiring laboratory determination (MAFF, 1982), they can be used to verify field visual assessments.

Soils with relatively high packing/bulk densities naturally occur where they are of a fine texture and/or have weak structural development. In the subsoil layers, a high density may not necessarily indicate compaction, but other structural characteristics of the soil. For the underlying C-horizon material, a high density would generally be expected. The occurrence of these profile characteristics should be taken into account in the SRMP. Professional soil surveyors can advise on the comparative packing densities of the in situ and reinstated soils, and on the potential for compaction and where compaction occurs (British Society of Soil Science, Undated).

Minimising Compaction

The complete avoidance of the compression of soils during soil handling (striping, storing and replacing soils) in mineral workings is unrealistic. However, measures to minimise significant increases in packing density (compaction) occurring can be deployed.

The main cause of compression is the traversing of soils with earth-moving machinery. The heavier the machines, the greater is the potential for compaction. Whilst machines differ in size and contact pressures (loaded and unloaded), it is usually the choice of machinery combination and handling practices that determine the degree and extent of compaction. The frequency of traversing the soils and soil condition, with the greater potential for significant compression occurring when wet (plastic), are likely to be contributing factors, but also can be the action in the loading of soils, loaded soils being carried, and the mounding of soils in stores. Consequently, in most circumstances, the best option available for soil handling is that based on excavator and dump truck and the bed/strip handling practice (Bransden, 1991; Moffat & Bending, 2006; Moffat, 2014).

Treating Compaction

Whilst natural physical and biological processes can over a very long period of time reduce induced

higher soil packing density closer to their original state, remedial treatment is needed to accelerate the processes of soil recovery.

Compacted materials can be broken up by physically 'digging' or 'ripping' or cultivating by mechanical means (Spoor & Foot, 1998; Spoor, 2006). Whilst this is referred to as 'de-compaction', the actual result is the reduction of the soil mass into smaller masses ('clods' (>10 cm in size) or 'fragments' (<10 cm)) which themselves remain in the compressed state. The effect in the short term (as a surrogate for natural soil structure) can facilitate plant root penetration, drainage and aeration through the voids between the soil clods/fragments and any planes of weakness created.

The longevity of such a surrogate for natural soil processes is dependent on soil characteristics (texture, aggregate stability) and biological activity such as plant roots or the addition and incorporation of organic matter to maintain the voids and planes of weakness. Subsequent practices which recompact the soil (which can easily reoccur in the short term through machinery trafficking and livestock) during the aftercare period need to be avoided.

Where compaction is identified or expected within the replaced soil profile and is of consequence for the intended land use and ecosystem services, treatment should be scheduled during or after the replacement process as it is completed; where this is omitted the only and often less satisfactory option (if agricultural equipment is relied upon) is for it to be undertaken from the soil surface during the aftercare period.

Treatment of compaction before soil replacement is unlikely to have any subsequent benefit as recompaction of the loosened clods/fragments is likely to take place in subsequent handling. For other reasons, such as the ease of recovery of the soil from storage mounds, some decompaction of the soil in situ may be achieved.

The effectiveness of loosening compacted soil layers is dependent on the tools and practices used, and on the soil type and its wetness

condition. The two principal tools used are digging buckets operated by excavators or tines drawn by bulldozers. Both can be effective in promoting plant root penetration, drainage and aeration at least in the short term, but are dependent on the practice used, discipline in application, and soil condition for their effectiveness. Both options can result in uneven soil surfaces which for agricultural uses may need secondary cultivation treatment such as the use of discs and/or the use of crumbler-bars. The cultivated soil should be sown/planted as soon as possible as the decompacted profiles will have a low bearing capacity until natural settlement has taken place (usually over the first winter). The choice of the finishing of the completed soil surface can be a matter of operational preference and experience, the intended land use, time taken and cost, and gradient limitations.

Decompaction by digging subject to the capability of the excavator and size of bucket, can be used on completed soil profiles where the entire profile is to be dug or dug to a particular depth. The digging of the final profile might be an option (Options 1 & 3) where the mixing of surface and underling soil horizons is not of concern. It is to be carried out as sequential retreating strips across the land to minimise recompaction as shown in Part Two, Sheet N. The digging of the surface layer to a limited depth can be used in combination with stone removal from the upper soil layer when specialist stone-rake buckets with rows of stub-tines are used.

The same digging treatment can be deployed to individual soil horizons (Option 2), where digging of the final profile is not an option because of soil mixing (see Supplementary Note 5), as they are laid and where stones/non-soil debris are to be sequentially removed without the excavator working on the soil layers.

The ripping with tines can also be used on completed profiles (Option 3) and/or sequentially to treat individual horizons (Options 1 & 2) as the profile is built up as shown in **Part Two, Sheet O**. It is to be carried out as sequential retreating strips across the final profile or individual horizons depending on the potential effectiveness of the tine size and configuration and capability of the pulling

power unit (Binns, 1983; Bacon & Humphries, 1987; Spoor & Foot, 1998). Importantly, the configuration of the tines must at least include tines that are centred on the bulldozer's caterpillar tracks to treat the recompaction caused.

Again, with the ripping of individual soil horizons as they are laid (Option 2), there is a risk of recompaction by where the bulldozer is working on overlying successive layer(s). To rectify this decompaction from the surface of the overlying layer or the final surface may be required (Bacon & Humphries, 1987; Spoor & Foot, 1998). The length of the tines determine the potential depth to which decompaction might take place, although the actual effective depth because of soil heave dragging on the tool bar, is less and needs to be taken into account when determining the option to rip from the final surface.

The lateral effectiveness of the tines is determined by their spacing and operating depth, the wider the spacing the less effective they are in breaking up compacted soil into clods/fragments and creating planes of weakness. As the number of tines affect the drag and the load being carried, and hence the power needed, the addition of wings enables a wider spacing and hence fewer tines (Binns, 1983; Spoor & Foot, 1998), provided that the tines are operating at optimal depth.

There is nothing wrong with using straight non-winged tines if they are close enough and can be pulled by the bulldozer or there is a sufficient number of overlapping of the passes. Experience has shown that to achieve consistent decompaction that is comparable with digging, overlapping parallel passes are required and this is more effective than other patterns such as 'cross-ripping' (Spoor & Foot, 1998).

The mode of action of the tines as they are drawn through the compacted layer is to create lateral forces that radiate in front of the tine that shatter the surface of the soil and deeper radiating forces that uplifting the soil mass and create fissures and planes of weakness (Spoor & Foot, 1998). The shallower the ripping process the less uplift and the closer the tines need to be to break up the soil. With

deeper ripping, the wider spaced they can be and this may be necessary to reduce the drag on the bulldozer unit.

With the use of both methods, the depth to the uppermost compacted layer may be the determining factor in the realisation of particular land uses and ecosystem services. In some cases, this will be at depth in the profile, whereas in others it will be shallower. Hence, the digging/ripping, final or sequential treatment being adopted needs to be co-ordinated with the requirement and the capability of the equipment being used and the intended afteruse and soil functions and environmental/ecosystem services to be provided.

Historically, there is a poor record in achieving the adequate treatment of soil compaction. This has been mainly because of :

- i) the inadequacy and poor condition of ripping equipment
- ii) lack of knowledge of how to use the equipment effectively and/or
- iii) the lack of supervision, and
- iv) its deployment when soils are too wet to be effective.

Given the importance of soil compaction in relation to soil handling, professional soil surveyors should be consulted on the potential for compaction and the significance (if any) for the intended land use and services to be provided, the effectiveness of decompaction options and practices, and to identify its occurrence and significance in the field (British Society of Soil Science, Undated).

The setting up and operation of the decompaction practice and equipment should be overseen by a competent person with advice from the professional soil surveyors. Where decompaction is important in achieving the intended land use and services, it should be monitored and as work proceeds and adjusting the practice/operation as necessary.

References

[Bacon A R & Humphries R N. 1987. Deep ripping: A more](#)

[effective and flexible method for achieving loose soil profiles. In Rainbow. A K M \(ed\). Advances in Mining Science & Technology 2: Reclamation, Treatment and Utilisation of Coal Mining Wastes. Elsevier, Amsterdam pp 321-330](#)

Ball B C & Munkholm L J, 2015. Visual Soil Evaluation: Realizing crop production with minimum environmental impact. CABI, Wallingford.

[Ball B C, Guimarães R M L, Cloy J M, Hargreaves P R, Shepherd T G & McKenzie BM , 2017. Visual soil evaluation: A summary of some applications and potential developments for agriculture. Soil and Tillage Research, 173, 114-124](#)

Binns W O, 1983. Treatment of surface workings, pp9 – 16. In, Reclamation of Mineral Workings to Forestry, Forestry Commission, Edinburgh.

[Bransden B E, 1991. Soil protection as a component of gravel raising. Soil Use and Management, 7, 3, pp 139-144](#)

[British Society of Soil Science. Undated. Working with soils series: Professional competency in soil science](#)

Hodgson J M, 1997. Soil survey field handbook: describing and sampling soil profiles. 3rd Edition. Soil Survey and Land Research Centre, Silsoe, Cranfield University.

MAFF, 1982. Reference Book 441: Techniques for measuring soil physical properties. Her Majesty's Stationery Office, London

Moffat A, 2014 Forest Research BPG Note 4: Loose Tipping. Forestry Commission, Farnham.

Moffat A J and Bending N A D, 2006. Replacement of soil and soil forming materials by loose tipping in reclamation to woodland. Soil Use and Management, 16, 2, 75-81.

Spoor G, 2006. Alleviation of soil compaction: requirements, equipment and techniques. Soil Use and Management, 22, 2, 113-122.

Spoor G and Foot K J, 1998. Soil compaction alleviation on restored sites. Pp 277 – 286. In, H R Fox, H M Moore & A D McIntosh (eds), Land Reclamation: Achieving Sustainable Benefits. A A Balkema, Rotterdam.

Supplementary Note 4 Soil Wetness

Soil wetness is a major determinant of land use, and environmental and ecosystem services in the UK. It is also a factor in the occurrence of significant compaction arising from handling soils with earth-moving machines and the practices used (Duncan & Bransden, 1986).

Relative soil wetness can range from the waterlogged to moist (mesic) or dry (xeric) depending on rainfall distribution and depth to a water-table and duration of waterlogging. In the UK, soil wetness is largely seasonal with higher evapo-transpiration rates potentially exceeding rainfall in the summer resulting in the soil profile becoming drier where there is vegetation. Whilst soil wetness is largely weather system and equinox (climate) driven, it varies with geographical and altitudinal locations, and importantly the physical characteristics of the soil profile, such as texture structure, porosity, and depth to the water-table and topography including flood risk (MAFF, 1988). The Soil Wetness Class is based on the expected average duration of waterlogging at different depths in the soil throughout the year (days per year), and can be determined by reference to soil characteristics and local climate (MAFF, 1988). The likely inherent wetness and resilience status of a soil should be indicated in the SRMP (see **Part 1, Table 2 & Supplementary Note 1**), reflecting potential risks for soil handling such as low permeability, permanently high groundwater, or a wet upland climate.

Wet soils can also be a result of other circumstances. For example, the interception of water courses, drainage ditches and field land drains. Where these occur, the provisions are to be made in the SRMP to protect the soils being handled and the operational area.

Soils, when in a wet condition generally have a lower strength and have less resistance to compression and smearing than when dry. Lower strength when soils are wet also affects the bearing capacity of soils and their ability to support the safe and efficient operation of machines than when in a

dry state.

In terms of resilience and susceptibility to soil wetness, the clay content of the soil largely determines the change from a solid to a plastic state (the water content at which this occurs is called the 'plastic limit' (MAFF, 1982)). This is the point at which an increasing soil wetness has reduced the cohesion and strength of the soil and its resistance to compression and smearing.

Whilst coarse textured sandy soils are not inherently plastic when wet, they are still prone to compaction when in a wet condition. Hence, handling all soils when wet will have adverse effects on plant root growth and profile permeability, which may be of significance for the intended land use and the provision of services reliant on soil drainage and plant root growth. It may be less so in other circumstances where wet soil profiles, perched water tables and ponding are the reclamation objectives, though drainage control, for example to control flooding, may still be important in these contexts.

In cases of permanently wet soils, such as riverine sites, upland or deep organic soils where there is a persistent high water-table throughout the seasons within the depth of soil to be stripped and/or the soil profile remains too wet, a strategic decision has to be made to be able to proceed with the development of the mineral resource. This may mean alternative and less favourable soil handling practices have to be agreed with the planning authority.

Predicting & Determination of Soil Wetness

There are well established methods to predict and determine soil wetness of undisturbed and restored soil profiles (Reeve, 1994). The challenge has been the prediction of the best time for soil stripping. Models based on soil moisture deficits and field capacity dates for a range of soil textures can provide indicative regional summaries (**Table 4.1**) that can help with planning operations at broad scale but cannot be relied upon in practice for deciding operationally whether to proceed on the ground given the actual variation in weather events from year to year and within years.



Soil Clay Content	Climatic Zones		
	1	2	3
Soil Depth <30cm			
<10%	Mid Apr - Early Oct	Late Mar – Early Nov	Late Mar – Early Dec
10 -27%	Late May - Early Oct	Early May – Early Nov	Early Apr – Early Dec
Soil Depth 30-60cm			
<10%	Late Apr - Early Oct	Mid Apr – Early Nov	Early Apr – Early Dec
10-27%	Late May - Early Oct	Early May – Early Nov	Early Apr – Early Dec
>27%	Late June – Early Oct	Early June – Early Nov	Late May – Early Dec
Soil Depth >60cm			
<10%	Late Apr - Early Oct	Mid Apr – Early Nov	Early Apr – Early Dec
10-18%	Late May - Early Oct	Early May – Early Nov	Early Apr – Early Dec
18-27%	Late June – Early Oct	Early June – Early Nov	Late May – Early Dec
>27	Mid July – Mid Sept	Early July – Mid Oct	Late June – Mid Oct

Table 4.1: Indicative on-average months when vegetated mineral soils might be in a sufficiently dry condition according to geographic location, depth of soil and clay content

The timing of most soil handling operations takes place between April and September. Although in western (Zone 1) and central (Zone 2) areas it typically can be a later start in May with an earlier termination in August. Whilst the return to climatically ‘excess rainfall’ is later in the eastern counties (Zone 3) and can be as late as November/early December, there is a need to maintain transpiring vegetation to keep the soils being handled in a dry as possible condition and to establish new vegetation covers as soon as possible (on replaced soils and storage mounds). Hence, soil handling operations generally need to be completed no later than the end of September (Natural England, 2021), unless appropriate provisions can be assured.

Where data is available, more realistic local and real-time predictions can be made, however, because weather patterns and events differ between and within years, and soils can vary locally in their condition. Experience has shown that the most practical approach for operations is to inspect the site and soils in question near to/at the time when soil handling is to take place. Professional soil surveyors can advise on the best time for soil handling (stripping, storage & replacement) and carry out site assessments of soil wetness condition prior to the start of operations.

A Practical Method for Determining Soil Wetness Limitation

During the soil handling season (see Table 4.1 above), prior to the start or recommencement of soil handling soils should be tested to confirm they are in suitably dry condition (Table 4.2). The ‘testing’ during operations can be done by suitably trained site staff and reviewed periodically by the professional soil surveyors.

The method is simply the ability to roll intact threads (3mm diameter) of soil indicating the soils are in a plastic and wet condition (MAFF, 1982; Natural England, 2021). Representative samples are to be taken through the soil profile and across the area to be stripped. It is the best available indicator of soils being too wet to be handled and operations should be delayed until a thread cannot be formed. For coarse textured soils which do not roll into threads, a professional’s view as to soil wetness and the risk of compaction may have to be taken.

Table 4.2: Field Tests for Suitably Dry Soils

Soil tests are to be undertaken in the field. Samples shall be taken from at least five locations in the soil handling area and at each soil horizon to the full depth of the profile to be recovered/replaced. The tests shall include visual examination of the soil and physical assessment of the soil consistency.

i) Examination

- If the soil is wet, films of water are visible on the surface of soil particles or aggregates (e.g. clods or peds) and/or when a clod or ped is squeezed in the hand it readily deforms into a cohesive 'ball' means **no soil handling to take place**.
- If the sample is moist (i.e. there is a slight dampness when squeezed in the hand) but it does not significantly change colour (darken) on further wetting, and clods break up/crumble readily when squeezed in the hand rather than forming into a ball means **soil handling can take place**.
- If the sample is dry, it looks dry and changes colour (darkens) if water is added, and it is brittle means **soil handling can take place**.

ii) Consistency**First test**

Attempt to mould soil sample into a ball by hand:

- Impossible because soil is too dry and hard or too loose and dry means **soil handling can take place**.
- Impossible because the soil is too loose and wet means no soil handling to take place.
- Possible - Go to second text.

Second test

Attempt to roll ball into a 3mm diameter thread by hand:

- Impossible because soil crumbles or collapses means soil handling can take place.
- Possible means no soil handling can take place.

N.B.: It is possible to roll most coarse loamy and sandy soils into a thread even when they are wet. For these soils, the Examination Test alone is to be used.

A Rainfall Protocol to Suspend & Restart Soil Handling Operations

Local weather forecasts of possible rainfall events during operations and the occurrence of surface lying water have been used to advise on a day-to-day basis if operations should stop (Natural England, 2021). Single events such as >5mm/day in spring and autumn months, and >10mm/day in the summer have been suggested as more precise triggers for determining soil handling operations (Reeve, 1994). However, in practice the following generic guidelines are often used:

- In light drizzle soil handling may continue for up to four hours unless the soils are already at/near to their moisture limit.
- In light rain soil handling must cease after 15 minutes.
- In heavy rain and intense showers, handling shall cease immediately.

In all of the above it is assumed that soils were in a dry condition. These are only general rules, and it is at the local level decisions to proceed or stop should be based on the actual wetness state of the soils being handled. After the above rain event has ceased, the soil tests in **Table 4.2** above should be applied to determine whether handling may restart, provided that the ground is free from ponding and ground conditions are safe to do so. There can be extreme instances where soil horizons have become very dry and are difficult to handle resulting in dust and windblown losses. In these conditions the operation should be suspended. The artificial wetting of extremely dry soils is not usually a practice recommended but has been successful in some cases.

References

[Duncan N A and Bransden B E. 1986. The effects on a restored soil caused by soil moving under different moisture contents. Applied Geography, 6, 3, pp 267-273](#)

MAFF, 1982. Reference Book 441: Techniques for measuring soil physical properties. Her Majesty's Stationery Office, London

[MAFF. 1988. Agricultural Land Classification Of England and Wales](#)

[Natural England. 2021. Planning and aftercare advice for reclaiming land to agricultural use](#)

Reeve M J, 1994. Improving land restoration in Britain by better timing of soil movement, pp 28-37. In, Proceedings American Society of Mining and Reclamation. DOI: 10.21000/JASMR94030028

Supplementary Note 5 Soil Mixing

The mixing of soil material can be both deleterious and beneficial, depending on circumstances, and if relied upon, needs special consideration of how it is to be achieved in the Soil Resource & Management Plan (SRMP).

Mixing of Soil Horizon Interfaces

The mixing of soil horizons at the interface can occur during soil stripping and replacement operations for several reasons such as, i) the lack of care taken in the operation, ii) failure to identify and communicate the distinction, iii) the physical impress of soil material during trafficking of machines traversing the soil, iv) spillage of soil when tipping and spreading during soil reinstatement, v) the result of decompaction by bucket or tines, but also vi) soil characteristics such as a gradation in change rather than distinct boundary, and vii) variation in horizon thickness and topography.

The significance of soil interface mixing depends on the extent as well as the intended land use and services. Mixing at the interface of soil layers is often beneficial for plant rooting and drainage, which can be impeded where there is an abrupt change in physical properties.

Wholesale Mixing of Soil Materials

Wholesale mixing of soil types and horizons can occur as a deliberate action or unintentionally. Its occurrence can be for various reasons, from being a consequence of poor record keeping of storage mounds, the absence of adequate soil resource plans to the consequence of soil importation schemes where there is a shortfall of soil material. The latter is often associated with long established inert fill and brown-field sites. Where importation of soils is to occur, it should meet prescribed standards (BSI, 2015) and be considered in detail in the SRMP. The former poor practices should be prevented by the adoption of the SRMP and good site oversight practices.

A common misunderstanding that results in soil mixing is the too literal interpretation of the Natural

England (2021) guidance that all topsoil should be stripped to 300mm, and subsoil should be stripped as a single 700mm layer. Soil horizons should be stripped according to their natural occurrence and separately according to their main functional characteristics (see Supplementary Note 1).

The mixing of soil types and horizons is sometimes advocated to 'improve' soil quality, as is the deliberate mixing of top- and subsoil to reduce topsoil fertility and other soil functions to achieve habitat creation schemes. Where this results in the degradation of soil capital, it should be approached with caution and requires evidence of the benefit to be provided in the SRMP before being adopted.

Historically, more effective than soil mixing has been the substitution of intractable soil horizons with other material, particularly soil forming material from within a site's geological horizons (Bending et al, 1999).

There are instances where the mixing of soil types and horizons are largely unavoidable because of the machinery used and spatial characteristics of the soils. Examples include thin lithomorphic soils on rock deposits and small-scale mosaics in warp and periglacial soils. Because of the practical limitations in recovering the individual thin soil horizons, the surface and sub-surface materials are often stripped together as a single layer, as are the lateral components of mosaics.

In all of the above situations, the professional soil surveyor should have identified these and advised in the SRMP how they are to be treated for stripping, storage and replacement to achieve the intended land use, soil functioning and ecosystem services.

References

Bending N A D, McRae S G & Moffat A J, 1999. Soil-forming materials: their use in land reclamation. Department of the Environment, Transport and the Regions. The Stationery Office, London.

[British Standards Institute, 2015. BS 3882:2015 Specification for topsoil](#)

[Natural England, 2021. Planning and aftercare advice for reclaiming land to agricultural use](#)

GLOSSARY OF TERMS

Apedal

No observable soil particle aggregation and lines of weakness in soil mass.

Basal layer

Unweathered material or fill/capping layer below soil layer not considered to be part of the soil profile/resource.

Clod

An artificial and less stable aggregation of soil particles ranging in sizes and shapes, can be a fragment of a ped.

Ecosystem services

The many benefits to humans provided by the natural environment and from healthy ecosystems, for example, extreme weather mitigation, flood control, clean drinking water, the decomposition of wastes, productivity of food and fibres, human mental and physical well-being.

Field Capacity

The maximum amount of soil water held in the soil after excess water has drained away.

Field Capacity Days

The number of days when the soil moisture deficit is zero.

Natural Capital

The world's stock of natural resources, which includes geology, soils, air, water, and all living organisms.

Ped

Natural stable aggregation of soil particles ranging in sizes and shapes (units of soil structure).

Reclamation

A term encompassing both restoration (the reinstatement of soils) and aftercare stages.

Soil consistency

The cohesion/adhesion of soil particles within the peds giving the characteristic of strength (resistance to crushing/deformation (ranging from loose, weak, firm, strong to rigid)).

Soil forming material

Non soil materials usually derived from mineral wastes, such as overburden materials and uneconomic geological materials encountered during quarrying or mining, that have the potential to turn into soils over time.

Soil function

Includes the physical support for plants and soil organisms, attenuation and drainage, water supply and purification, nutrient accumulation and cycling.

Soil sealing

The temporary careful compaction/smearing of a soil surface by a bulldozer or excavator to reduce the infiltration of precipitation and the wetting of the soil profile.

Soil plastic limit

The water content at which soil material becomes plastic (mouldable) and prone to compression and smearing. Although the plastic limit is not manifest in sandy soils, they are prone to compression at high water contents.

Soil structure

The shape (granular to prismatic/platy), size (fine to very coarse) and degree of aggregation (weak, moderate, strong) of soil particles into structural units (peds) and voids, and their spatial arrangement.

Soil texture

The size distribution (sand, silt & clay sized particles) of less than 2mm fraction of soil material.

Soil Textural Class

Eleven main groupings of soil particle distributions according to the proportions of sand, silt and clay sizes.

Soil wetness

And 'wet soil', a generic term to denote water content at or above the soil's plastic limit.

Soil Wetness Class

Six groupings of the depth to (slowly permeable/compacted layer) and duration of waterlogging in the soil profile.

Subsoil

The physio-chemically and biologically altered layers below the topsoil that are functioning parts of the soil profile, in some cases this includes part of the parent rock/drift materials.

Topsoil

The uppermost and most physically and biologically altered horizon, excluding organic litter layer, of undisturbed soil profiles.

GOOD PRACTICE GUIDE FOR HANDLING SOILS

In Mineral Workings

PART TWO: Methodology

- Sheet A -

Soil Stripping with Excavators and Dump Trucks
– Sequential Bed/Strip Practice

Author: Dr R N Humphries CBiol CSci FRSB FBSSS FIQ
- Blakemere Consultants Ltd & Celtic Energy Ltd

Supporting artwork was provided by R Shelton (H J Banks & Co)
and D Fisher (Blue Room Graphics Ltd).

Preface

The purpose of Sheet A of the updated guidance is to provide a model method of best practice where excavators and dump trucks are to be used to strip soil using the sequential ‘bed’/strip by strip practice.

The guidance is intended for use by planning officials, statutory consultees, mineral operators and their supporting teams and specialist consultants, and earth-moving contractors, their site supervisors and machine operators.

Successful soil handling schemes are dependent on the soil resources being clearly identified and the conditions in which they are to be handled. This information should be contained in the Soil Resource & Management Plan (SRMP) and communicated to those involved in its implementation.

Key issues to be addressed are:

- i) Avoiding conditions when soils are wet/plastic during handling
- ii) The minimisation of soil compaction caused by trafficking and soil wetness
- iii) Using appropriate remedial treatments where these are necessary
- iv) Minimising soil loss, and mixing of soil layers or different soil types.

The SRMP should specify the type of earth-moving machinery and soil handling practice, and the soil wetness condition (see Part One of the Guidance) to be deployed to achieve the planned after use, soil functioning, and the environmental and ecosystem services. It is to be communicated in full to all involved and in particular to the supervisors and machine operators by appropriate means; including tool-box talks and site demonstrations. Supervision by trained supervisory staff is essential, as are monitoring and reporting.

The guidance does not specify the size or model of equipment as this is left to the mineral operator and contractor to specify and provide. The machines must be of a kind which are appropriate for the task and the outcomes required, and to be able to carry out the work safely and efficiently.

Should the agreed methodology need to be modified or changed significantly, this should be agreed in advance with the mineral planning authority. The SRMP should include a mechanism whereby unexpected less significant changes can be quickly resolved through consultation between the operator, the planning authority and statutory consultee, and soil specialist.

All persons involved in the handling of soils must comply with all relevant legislation with respect to Health and Safety, in particular the Health and Safety at work Act 1974, and in the case of mineral extraction operations, The Quarries Regulations 1999 and its relevant statutory provisions; in particular those aspects which relate to the construction and removal of tips, mounds and similar structures. These requirements take preference over any suggested practice in this Sheet and the SRMP should have taken these into account.

The users of this guidance are solely responsible for ensuring it complies with all safety legislation and good practice, including the manufacturer’s specifications for the safe operation of the specific machines being used, and that all machines are in a good condition and well maintained and are suitable for the task. It is important that those involved in the operation of earth moving machines are competent and have the necessary training and certification.

Introduction

In this soil handling option, back-acting excavators are used to lift the soil resources and load them into dump trucks for the direct transport to the area being restored or to storage until needed.

The stripping practice involves the sequential separation and removal of the individual layers of soil identified in the Soil Resource & Management Plan (SRMP). It takes the form of advancing vertical slices through the soil profile as successive strips across the soil being removed. Hence the practice is often referred to as the 'Strip' or 'Bed' method.

The upper layer (topsoil) in the strip being removed is lifted first within the safe and efficient operational reach of the excavator boom (which defines the width of each strip). For each subsequent soil layer, if it is to be recovered, the process is repeated until the basal layer (usually overburden or the economic mineral layer) is reached. When the soil resource/profile sequence within the strip is completely removed, the process is repeated on the abutting area to be stripped of soil. The method can also be adopted where only a single soil horizon is to be recovered.

Normally the excavator operates only from on the soil surface with the dump trucks travelling on the exposed lower non-soil layer. This the preferred operating mode of the excavator as there is a better recovery of the particular soil layer on handling. In some circumstances, such as where, i) the topsoil/surface layer has a particularly low baring capacity and is prone to compaction (such as peat or organic soils), ii) a thin soil layer lies directly on the mineral layer, or iii) access is limited from the bottom of steep gradients, the excavator will need to operate from the exposed 'basal' mineral/overburden layer or a raised access strip.

Similarly, the normal operation of the dump trucks is on the exposed non-soil basal/overburden layer. In cases where the soil horizon has i) a particularly low baring capacity or ii) where there needs to be enhanced protection of potential archaeological features, the dump trucks may have to operate upon the topsoil which may have to be surcharged.

Advantages & Disadvantages

The advantages of this machinery combination and handling practice are:

- i) When the excavator operates only from on the soil surface, compaction is largely confined to the top-soil (which is ultimately more easily treated) and potentially reducing the risk of severe compaction of the subsurface soil layers where the soil is to be directly placed without storage
- ii) It is easier to see and react to localised changes in soil types and variation in horizon depth
- iii) It is suited to the stripping of thin and 'patterned' soil layers
- iv) It offers the most flexibility in respect of short soil drying periods and likely wet weather as it is less susceptible to stoppages due to soil rewetting as a transpiring vegetation cover can be retained later into the stripping programme. It is particularly suited to northerly and western, and upland locations, and particularly when there are uncertain weather patterns.

The disadvantages are:

- i) It requires skill and discipline in its deployment, and a high level of supervision, being suited to experienced operators
- ii) Without care the bed system may result in a greater mixing of soil horizons
- iii) Steep gradient/complex topographies may limit the safe and practical deployment of this machinery combination and handling practice.

Suitability

The excavator-dump truck combination with the bed/strip handling practice methodology is considered as 'best practice' by Natural England and the Welsh Government for agricultural soils and preferred for all soils. In particular, it is the most suitable of any of the methods available where:

- i) The soil is prone to compaction and where decompaction treatments cannot be relied upon to be effective (this includes peat)
- ii) The intended after use, environmental and ecosystem services are dependent on

maintaining (as far as it is possible) the soil functional characteristics such as, porosity and hence drainage and aeration, plant available water capacity, and low resistance to plant root growth. This includes productive agricultural, horticultural and forestry land, but also some natural habitats, and where water storage/infiltration is of importance for risk of flooding. Where the soils are stored prior to replacement some remedial treatment may have to be relied upon.

- ii) The bed/strip soil handling method is not suitable where an archaeological surface needs to be investigated as a whole. Subject to approval by the planning authority the method can be used with care where there is a 'watching brief' by an archaeologist, but may have to be abandoned for another approach where important artefacts are detected. However, trafficking may be restricted to the topsoil surface until the subsoil has been approved for removal and taken away.
- iii) The placement of the stripped soils into stockpiles is likely to result in compression and compaction and may negate this particular benefit of the handling practice.
- iv) As the benefit of the practice lies in the direct placement of the stripped soil it calls for the mineral extraction scheme to be organized to minimize the need for soils storage.

MODEL METHODOLOGY

A.1 Key operational points to minimise the risk of severe soil compaction and wet soil conditions are summarised in Boxes A.1 and A.2.

A.2 The timing of soil handling operations should only take place when the soils are in a 'dry and friable' condition (ie when it breaks and shatters when disturbed rather than smears and deforms) (see **Part One, Supplementary Note 4**). Prior to the start or recommencement of soil handling, they should be tested to confirm they are in suitably dry condition (see Box A.3).

Box A.1 - to minimise compaction:

- The dump trucks should normally only operate on the 'basal'/non-soil layer, and their wheels must not run on to the soil layer/s
- The excavator should normally operate on the topsoil layer
- The adoption of a bed/strip system avoids the need for the trucks to travel on the soil layers
- The machines are to only work when ground conditions enable their efficient operation
- Soils are to be in a 'dry' condition.

Box A.2 - to minimise soil wetness and re-wetting:

- The bed/strip system provides a basis to regulate the exposure of lower soil layers to periods of rain and a means of maintaining soil moisture contents. The soil profile within the active strip should be stripped to the basal layer before rainfall occurs and before stripping is suspended
- Measures are required to protect the face of the soil layer from ponding of water and maintain the basal layer in a condition capable of supporting dump trucks
- The area to be stripped is to be protected from in-flow of water, ponding etc. Wet sites should be drained in advance
- The maintenance of a transpiring crop is important, and an appropriate cropping regime should be established for the year of soil stripping
- Before stripping, excess vegetation should be removed; in the case of grassland it should be cut or grazed short and arable crops should have been harvested.

A.3 Soil handling is not to take place during rain, sleet or snow and in these conditions should be prohibited due to unsafe machine operating conditions. Prior to commencing operations, a medium/long term weather forecast should be obtained which gives reasonable confidence of soil handling being completed without significant

Box A.3 - Test for Dry and Friable Soils

Soil tests are to be undertaken in the field. Samples shall be taken from at least five locations on the soil handling area and at each soil horizon to the full depth of the profile to be recovered/replaced. The tests shall include visual examination of the soil and physical assessment of soil consistency.

i) Examination

- If the soil is wet, films of water are visible on the surface of soil particles or aggregates (e.g. clods or peds) and/or when a clod or ped is squeezed in the hand it readily deforms into a cohesive 'ball' means **no soil handling to take place**
- If the sample is moist (i.e. there is a slight dampness when squeezed in the hand) but it does not significantly change colour (darken) on further wetting, and clods break up/crumble readily when squeezed in the hand rather than forming into a ball means **soil handling can take place**
- If the sample is dry, it looks dry and changes colour (darkens) if water is added, and it is brittle means **soil handling can take place**

ii) Consistency**First Test**

Attempt to mould soil sample into a ball by hand:

- Impossible because soil is too dry and hard or too loose and dry means soil handling can take place
- Impossible because the soil is too loose and wet means no soil handling to take place
- Possible - GO TO SECOND TEST

Second Test

Attempt to roll ball into a 3mm diameter thread by hand:

- Impossible because soil crumbles or collapses means **soil handling can take place**
- Possible means **no soil handling to take place**

NB: It is impossible to roll most coarse loamy and sandy soils into a thread even when they are wet. For these soils, the Examination Test alone is to be used.

Box A.4 - Rainfall Criteria:

- In light drizzle soil handling may continue for up to four hours unless the soils are already at/near to their moisture limit
- In light rain soil handling must cease after 15 minutes
- In heavy rain and intense showers, handling shall cease immediately

In all of the above, after rain has ceased, soil tests shall be applied to determine whether handling may re-start, provided that ground conditions are safe to do so.

interruptions from rainfall events. The soil based criteria set out in Box A.4 are to be used to determine whether soil handling should cease or be interrupted with the occurrence of rain.

A.4 All machines must be in a safe and efficient working condition at all times. The machines are to only work when ground conditions enable safe and efficient operation. Otherwise the operation is to be suspended until suitable remedial measures can be put in place.

A.5 The operation should follow the detailed stripping plan set out in the SRMP showing soil units to be stripped, haul routes and the phasing of vehicle movements. The different soil units to be kept separate are to be marked out and information to distinguish types and layers, and ranges of thickness needs to be conveyed to the operational supervisor/operator. The haul routes and soil storage areas must be defined and should be stripped first in a similar manner. Detailed daily records should be kept of operations undertaken, and site and soil conditions.

A.6 Within each soil unit the soil layers above the base/formation layer are to be stripped in sequential strips with the topsoil layer stripped first, followed by the subsoil layers; each layer stripped to its natural thickness without incorporating material from the lower layers. The next strip is not started until the current strip is completely stripped to the basal layer. The system involves the progressive stripping of the soil in strips (**Figure A.1**).

Box A.5

In doing so, compaction by the excavator is largely restricted to the upper layer of soil, which is more easily treated after the soil has been relaid. The degree of topsoil compaction will depend on the machine's ground pressure, its mode of operation and soil wetness. Smaller wide tracked excavators may cause less compaction.

A.7 Unless specified in the SRMP, the excavator is only to work on the topsoil layer and the dump trucks are only to travel on the basal/formation layer (Box A.5).

A.8 Stripping is to be undertaken by the excavator standing on the surface of the topsoil and digging the topsoil to its maximum depth, and it loading into dump trucks. The dump trucks draw alongside the exposed soil profile, standing and travelling only on the basal layer (**Figure A.2**). The type of bucket to be used largely depends on the nature of the soil (Box A.6).

A.9 The initial strip width and axis should be demarcated. The strip width is determined by the length of the excavator boom less the stand-off to safely operate; typically, about 3-4m (Box A.7). Excavators with long booms ('long reach') can be used, but may be more restricted by gradient limitations, and require skilled and experienced operators.

A.10 Topsoil should be recovered to the full width of the strip without mixing with the underlying subsoil (not more than 20% of the lower horizon should be exposed at the layer junction within the strip). The thickness and identification of the horizon junction must be verified before and during stripping. The full thickness of the topsoil horizon should be stripped progressively along the strip before the underlying subsoil horizon(s), if present, is to be started (**Figure A.2**).

Box A.6

For hard/stony soils toothed buckets are needed. Where the mixing of soil layers at their interface is to be minimized, a bucket with a 'blade' is preferable where the soil is 'soft' and free of large stones or stone free. Where there is a watching archaeological brief, the use of bladed buckets will normally be required.

Similarly the choice of bucket type, whether it is a standard 'digging'/bulking or wide ditching type will depend on the soil strength and stoniness.

A.11 The (upper) subsoil in the current strip is then to be stripped and monitored in the same manner. The final 25cm of the subsoil layer should be left as a step to protect the adjacent topsoil layer from local collapses. On completion, the process is to be repeated if there is a lower subsoil, and then any other lower layer to be recovered as a soil material (**Figure A.3**).

Box A.7 - Orientation of the Excavator

Usually the excavator is orientated and operates with its tracks at 90° to the axis of the bed being stripped as this is the most stable position.

Whilst the reach of the boom and hence the width of the bed/strip can be significantly increased and the excavator trafficking over the soil surface decreased by orientating it with the tracks parallel to the soil being stripped, this may affect the stability of the excavator, particularly on a gradient or where soils have a low bearing capacity. Hence its safe deployment needs to be checked before its adoption.

A.12 On completion of the strip, the procedures are repeated sequentially for each subsequent strip until the soil to be stripped is completely removed.

A.13 Where the soils are to be directly replaced (without storage in mounds), the initial strip of the upper horizons will have to be stored temporarily to

release the lowest layer and enable the sequential movement of materials. The stored initial soil material would normally be placed on the lower layer removed from the final strip at the end of the programme or on partially completed profiles if rain interrupted the operation.

A.14 Where the stripping operation is likely to be interrupted by rain, or there is likely to be overnight rain, remove any exposed subsoil down to the basal layer before suspending operations. Make provisions to protect base of current or next strip from ponding/runoff by sumps and grips, and also clean and level the basal layer. At the start of each day ensure there is no ponding in the current strip or operating areas, and the basal layer is to level with no ruts.

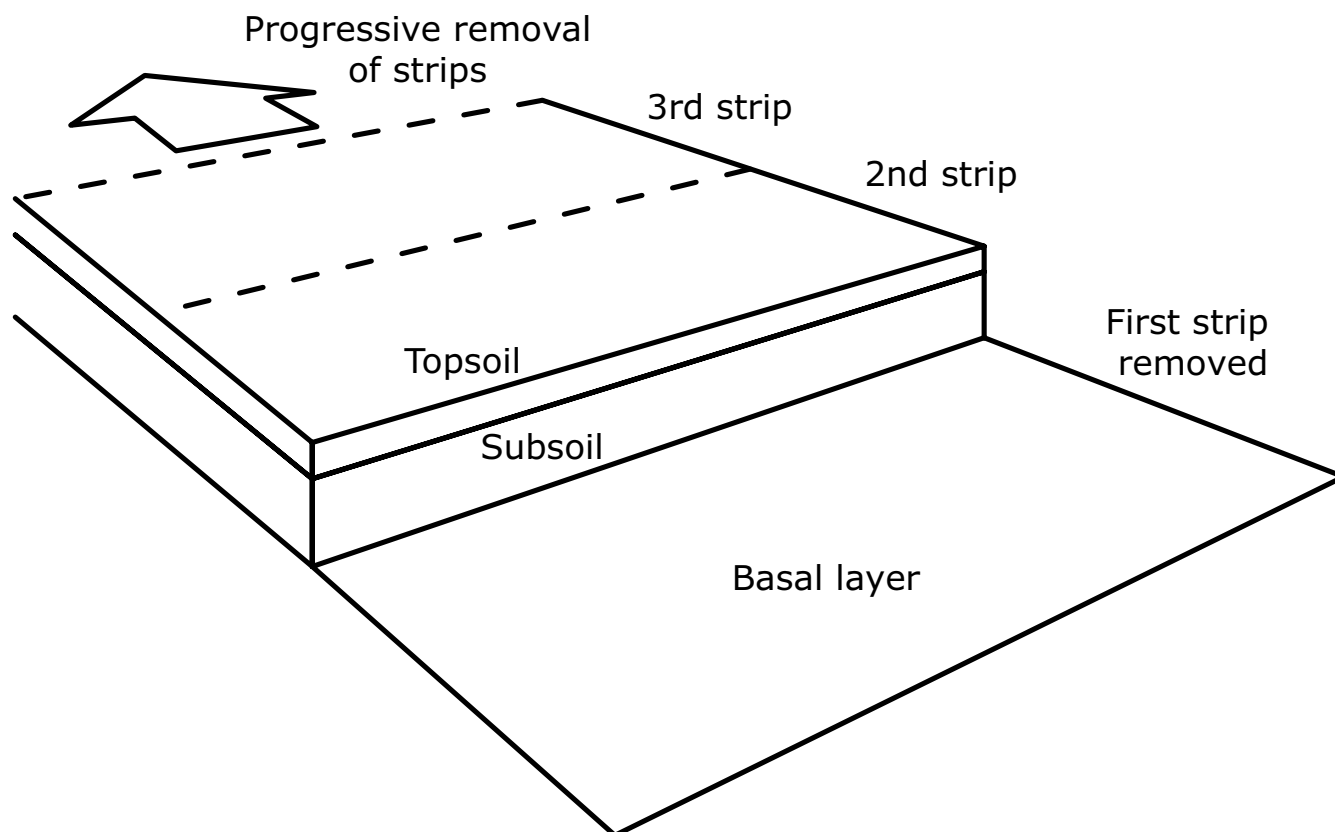

Figure A.1: Soil stripping with excavators and dump trucks: The bed system.

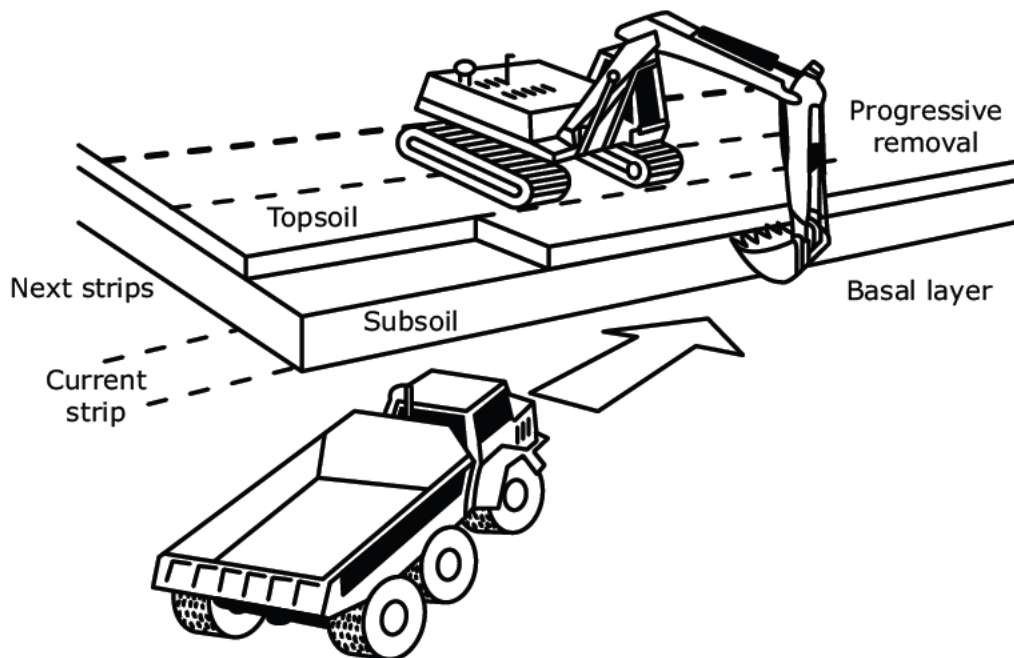

Figure A.2: Stripping with excavators and dump trucks: removal of topsoil from a strip.

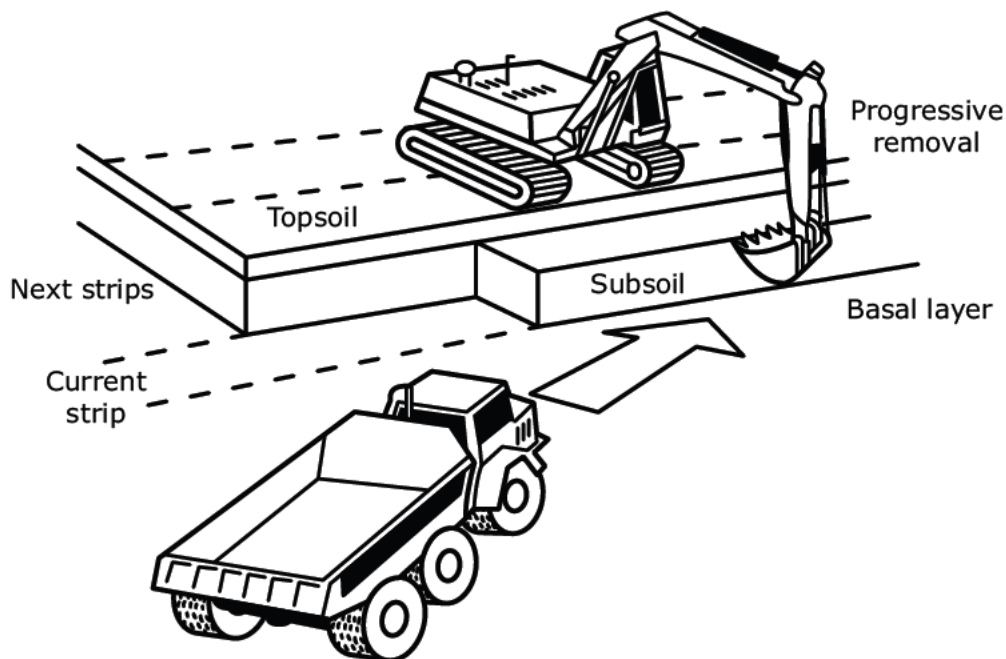

Figure A.3: Stripping with excavators and dump trucks: removal of subsoil from a strip.

GOOD PRACTICE GUIDE FOR HANDLING SOILS

In Mineral Workings

PART TWO: Model Methodology

- Sheet B -

Building Soil Storage Mounds
with Excavators and Dump Trucks

Author: Dr R N Humphries CBiol CSci FRSB FBSSS FIQ
- Blakemere Consultants Ltd & Celtic Energy Ltd

Supporting artwork was provided by R Shelton (H J Banks & Co)
and D Fisher (Blue Room Graphics Ltd).

Preface

The purpose of Sheet B of the guidance is to provide a model method of best practice where excavators and dump trucks are to be used to build soil storage mounds.

The guidance is intended for use by planning officials, statutory consultees, mineral operators and their supporting teams and specialist consultants, and earth-moving contractors, their site supervisors and machine operators.

Successful soil handling schemes are dependent on the soil resources being clearly identified and the conditions in which they are to be handled. This information should be contained in the Soil Resource & Management Plan (SRMP) and communicated to those involved in its implementation.

Key issues to be addressed are:

- i) Avoiding conditions when soils are wet/plastic during handling
- ii) The minimisation of soil compaction caused by trafficking and soil wetness
- iii) Using appropriate remedial treatments where these are necessary
- iv) Minimising soil loss, and mixing of soil layers or different soil types.

The SRMP should specify the type of earth-moving machinery and soil handling practice, and the soil wetness condition (see Part One of the Guidance) to be deployed to achieve the planned after use, soil functioning, and the environmental and ecosystem services. It is to be communicated in full to all involved and in particular to the supervisors and machine operators by appropriate means; including tool-box talks and site demonstrations. Supervision by trained supervisory staff is essential, as are monitoring and reporting.

The guidance does not specify the size or model of equipment as this is left to the mineral operator and contractor to specify and provide. The machines must be of a kind which are appropriate for the task and the outcomes required, and to be able to carry out the work safely and efficiently.

Should the agreed methodology need to be modified or changed significantly, this should be agreed in advance with the mineral planning authority. The SRMP should include a mechanism whereby unexpected less significant changes can be quickly resolved through consultation between the operator, the planning authority and statutory consultee, and soil specialist.

All persons involved in the handling of soils must comply with all relevant legislation with respect to Health and Safety, in particular the Health and Safety at work Act 1974 and in the case of mineral extraction operations, The Quarries Regulations 1999 and its relevant statutory provisions; in particular those aspects which relate to the construction and removal of tips, mounds and similar structures. These requirements take preference over any suggested practice in this Sheet and the SRMP should have taken these into account.

The users of this guidance are solely responsible for ensuring it complies with all safety legislation and good practice, including the manufacturer's specifications for the safe operation of the specific machines being used, and that all machines are in a good condition and well maintained and are suitable for the task. It is important that those involved in the operation of earth moving machines are competent and have the necessary training and certification.

Introduction

This soil handling method uses back-acting excavators to build the storage mound in combination with dump trucks to transport the soil. Either the excavator sits on the basal layer and casts the tipped soil into a mound or it sits on the tipped soil and pulls it into a mound. The latter is preferred as it is easier to form the mound. In many cases low ground pressure bulldozers are used to grade and trim the finished mound.

Top- and subsoil(s) are to be stored in separate mounds or in clearly defined parts of mounds, in some circumstances where the topsoil can be easily recovered it may be laid over the subsoil.

The space available for storage in mineral workings is often limited and this determines the 'height' of mounds. For topsoil the preference is for 1 to 3m height in order to minimize the impact of storage on biological processes, whereas for subsoils where the biological activity is lower, subject to safe operations, mounds are often raised to heights of 3 to 5m depending on the resilience of the soils to compaction (see Part One & Supplementary Note 3).

In this soil handling option, the mounds are either built as one 'tier' or 'multi-tier' high. In the single tier only the excavator and if used the bulldozer traffic the tipped soil surface and usually the final surface. Whilst, in the multi-tier mounds it is also trafficked by loaded dump trucks.

Advantages & Disadvantages

Storage vs Direct Placement:

The advantages of storage are:

- i) It gives flexibility in the operation of the mineral site
- ii) Flexibility (i.e. weather and ground conditions) for when it is reused.

The disadvantages are:

- i) There is an high risk of compaction of the soil material by stacking in the mound which later cannot be effectively treated
- ii) There may be significant degradation of biological functions with long-term storage.

Single vs Multi-tier Mounds:

The advantage of multi-tier mounds is that they take less space. The disadvantages are:

- i) With multi-tier mounds there is high risk of severe compaction of the soil material layers by repeated trafficking by laden dump trucks in the building of multi-tier mounds which later cannot be effectively treated
- ii) There may be a longer delay in recovery of the soil's biological functions on replacement.

Suitability

Soil storage is less suitable where:

- i) The subsoil(s) are significantly less resilient to compaction (such as silts and sandy clay loams) and when decompaction treatments cannot be relied upon to be effective because of a risk of soil wetness or operational limitations (such as the unavailability of effective decompaction tools) (see **Part One and Supplementary Notes 3 & 4**)
- ii) The intended after use, environmental and ecosystem services are dependent on maintaining functional characteristics such as soil porosity and hence drainage and aeration, plant available water capacity, and low resistance to plant root growth. This usually includes the most productive agricultural, horticultural and forestry land, many types of natural habitats, and where water storage/infiltration is of importance for the risk of flooding
- iii) The bed/strip practice using excavators is used (Sheet A) as the compaction caused can negate its benefit
- iv) Multi-tier mounds are used, particularly where the intended after use, and the environment and ecosystem services are dependent on maintaining functional characteristics such as soil porosity and hence drainage and aeration, plant available water capacity, and low resistance to plant root growth. This usually includes the most productive agricultural and forestry land, many types of natural habitats, and where water storage/infiltration is of importance for the risk of flooding.

MODEL METHODOLOGY

B.1 Key operational points to minimize the risk of severe soil compaction and soil wetness are summarised in Boxes B.1 and B.2.

Box B.1 - To minimize compaction:

- strip in advance the soil to basal layer along haul routes and the operational footprint of the storage mound
- dump trucks are only to stand and travel on the basal layer (unless raising the next level in multi-tier mounds)
- the machines are to only work when ground or soil surface conditions enable their efficient operation
- single-tier mounds should be prioritised over multi-tier mounds as it avoids the need for trafficking on the soil being stored
- raise the soil using only the excavator and maximise the mound height before trucks allowed to access upper surface
- in the raising of multi-tier mounds, trafficking is to be confined to the upper surface of the lower tier. This layer will require decompaction on excavation of the mound.

B.2 The timing of the building of the soil storage mounds will be governed by the weather and soil conditions governing stripping (see **Sheets A, E, F, I**). Unless the soils are required to be kept in a wet state (eg peat), the mounds should be sited on dry ground, not in hollows and should not disrupt local surface drainage (Box B.3). Where necessary mounds should be protected from run-off/ponding by a cut-off ditch which is linked to appropriate water discharge facilities. Where the storage mound is in a hollow due to the removal of surface soils, measures should be undertaken to ensure that water is not able to pond within the storage area.

B.3 All machines must be in a safe and efficient working condition at all times. The machines are to only work when ground conditions enable safe and efficient operation. Otherwise the operation is to be suspended until suitable remedial measures can be

put in place.

Box B.2 - To minimize the wetting of soils:

- soil mounds to be built in dry/draining/drained locations and protect from run-off from adjacent areas
- raise the soil mound to maximum height progressively along the axis of the mound, and shape the mound as it is being built to shed water and seal exposed surfaces whenever stripping is suspended
- measures are required to protect the face of the soil layer from ponding of water and maintain the basal layer in a condition capable of supporting dump trucks.

Box B.3

Where soils such as peat need to be kept in a wet condition this may require storage in (bunded) cells where receiving rainfall cannot drain.

B.4 The operation should follow the detailed stripping/storage plan set out in the SRMP showing soil units to be stripped, haul routes and the phasing of vehicle movements. Different soil units to be kept separate are to be marked out and information to distinguish types and layers, and ranges of thickness needs to be conveyed to the operational supervisor/operator. The haul routes and soil storage areas must be defined and should be stripped first in a similar manner. Detailed daily records should be kept of operations undertaken, and site and soil conditions.

B.5 Adopting the practices outlined in **Sheet A**, where relevant, remove topsoil and subsoil to basal layer from the haul routes, footprint of the storage mound and any other operating area in advance. The soils should be stored in their respective mounds.

B.6 The dump trucks must only travel within the haul route and operational areas. Typically the trucks should enter the storage area, reverse and tip the soil load starting at the furthest point of the

mound from the point of access. The back-acting excavator pulls up the soil into a mound of the required dimensions (Box B.4). The excavator operates by standing on the mound (**Figure B.1**) or the stripped basal layer. The excavator bucket can be used to shape and firm the sides as the mound is progressively formed to promote the shedding of rain.

B.7 The process is repeated with the tipping of soil against the forming mound, and without the dump truck wheels traversing onto previously tipped material. The operation continues progressively along the main axis of the mound.

Box B.4 - Choice of Bucket Type

For hard /stony soils toothed buckets are needed. Where the mixing of soil layers at their interface is to be minimized, a bucket with a 'blade' is preferable where the soil is 'soft' and free of large stones or stone free. Where there is a watching archaeological brief, the use of bladed buckets will normally be required.

Similarly, the choice of bucket type, whether it is a standard 'digging'/bulking or wide ditching type will depend on the soil strength and stoniness.

B.8 Without the trucks rising onto the soil mound, the maximum possible height and width of the mound is related to the boom reach of the excavator (typically about 3-4m). Excavators with long booms ('long reach') can be used, but may be more restricted by gradient limitations, and require skilled and experienced operators.

B.9 To raise the mound higher, as a multi-tier mound, the trucks will have to travel on the upper surface of the mounded soils (first tier). In this case the mound should be raised to its maximum height (**Figure B.2**). A ramp will have to be provided for the trucks to rise onto the surface of the first tier, which should be capable of trafficking safely and without difficulty. The next tier would be formed repeating the process described above.

B.10 If further tiers are required, the process would

be repeated. Any exposed edges/surfaces should be shaped using the excavator bucket on the onset of rain during the day, this should include any exposed incomplete surfaces. All surfaces should be shaped to shed water at the end of the day. The final outer surface should be progressively shaped using the excavator bucket or low ground pressure bulldozer to promote the shedding of rain.

B.11 Work should stop in wet conditions (Box B.5) with measures undertaken to shed water from the soil surfaces and to prevent ponding at the base of the mound and on the basal layer. At the start of each day ensure there is no ponding on the basal layers and operating areas.

Box B.5 - Rainfall Criteria

- In light drizzle soil handling may continue for up to four hours unless the soils are already at/near to their moisture limit
- In light rain soil handling must cease after 15 minutes
- In heavy rain and intense showers, handling shall cease immediately

In all of the above, after rain has ceased, soil tests shall be applied to determine whether handling may re-start, provided that the ground is free from ponding and ground conditions are safe to do so.

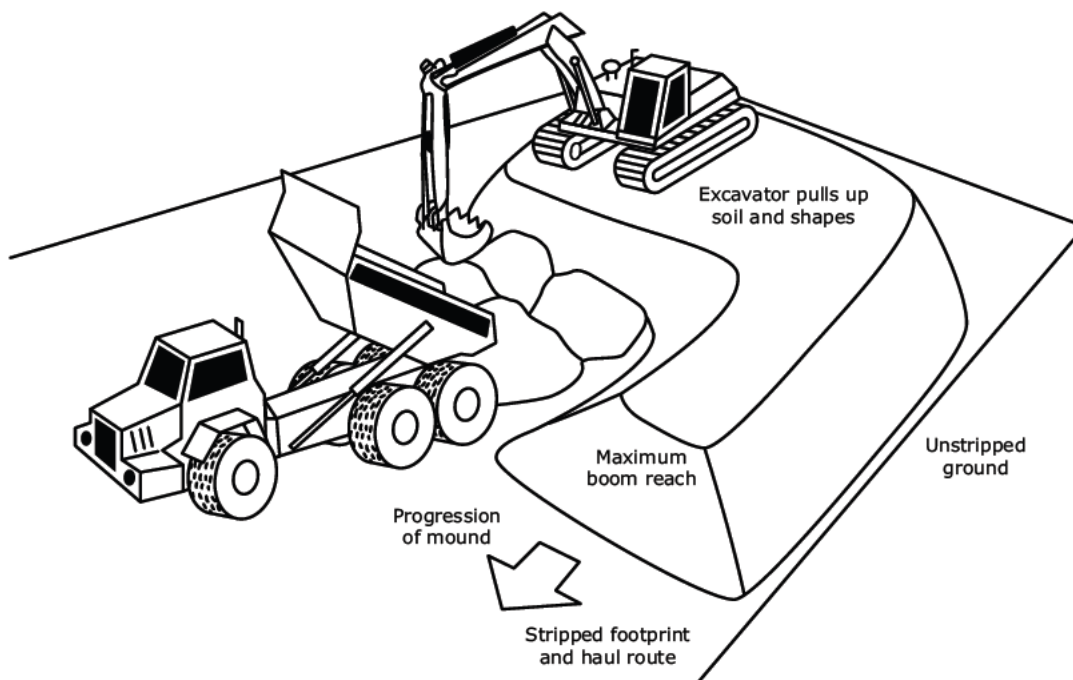

Figure B.1: Soil storage mound construction with excavators and dump trucks: Single tier mound.

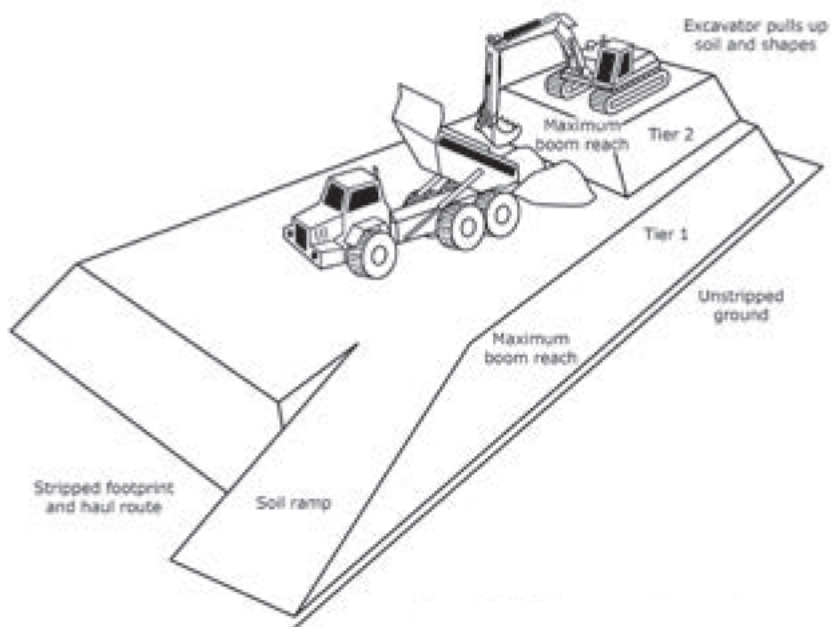

Figure B.2: Soil storage mound construction with excavators and dump trucks: Multi-tier mound.

GOOD PRACTICE GUIDE FOR HANDLING SOILS

In Mineral Workings

PART TWO: Model Methodology

- Sheet C -

Excavation of Soil Storage Mounds
with Excavators and Dump Trucks

Author: Dr R N Humphries CBIol CSci FRSB FBSSS FIQ
- Blakemere Consultants Ltd & Celtic Energy Ltd

Supporting artwork was provided by R Shelton (H J Banks & Co)
and D Fisher (Blue Room Graphics Ltd).

Preface

The purpose of Sheet C of the guidance is to provide a model method of best practice where excavators and dump trucks are to be used to recover soils from storage mounds.

The guidance is intended for use by planning officials, statutory consultees, mineral operators and their supporting teams and specialist consultants, and earth-moving contractors, their site supervisors and machine operators.

Successful soil handling schemes are dependent on the soil resources being clearly identified and the conditions in which they are to be handled. This information should be contained in the Soil Resource & Management Plan (SRMP) and communicated to those involved in its implementation.

Key issues to be addressed are:

- i) Avoiding conditions when soils are wet/ plastic during handling
- ii) The minimisation of soil compaction caused by trafficking and soil wetness
- iii) Using appropriate remedial treatments where these are necessary
- iv) Minimising soil loss, and mixing of soil layers or different soil types.

The SRMP should specify the type of earth-moving machinery and soil handling practice, and the soil wetness condition (see Part One of the Guidance) to be deployed to achieve the planned after use, soil functioning, and the environmental and ecosystem services. It is to be communicated in full to all involved and in particular to the supervisors and machine operators by appropriate means; including tool-box talks and site demonstrations. Supervision by trained supervisory staff is essential, as are monitoring and reporting.

The guidance does not specify the size or model of equipment as this is left to the mineral operator and contractor to specify and provide. The machines must be of a kind which are appropriate for the task and the outcomes required, and to be able to carry out the work safely and efficiently.

Should the agreed methodology need to be modified or changed significantly, this should be agreed in advance with the mineral planning authority. The SRMP should include a mechanism whereby unexpected less significant changes can be quickly resolved through consultation between the operator, the planning authority and statutory consultee, and soil specialist.

All persons involved in the handling of soils must comply with all relevant legislation with respect to Health and Safety, in particular the Health and Safety at work Act 1974 and in the case of mineral extraction operations, The Quarries Regulations 1999 and its relevant statutory provisions; in particular those aspects which relate to the construction and removal of tips, mounds and similar structures. These requirements take preference over any suggested practice in this Sheet and the SRMP should have taken these into account.

The users of this guidance are solely responsible for ensuring it complies with all safety legislation and good practice, including the manufacturer's specifications for the safe operation of the specific machines being used, and that all machines are in a good condition and well maintained and are suitable for the task. It is important that those involved in the operation of earth moving machines are competent and have the necessary training and certification.

Introduction

This soil handling method uses back-acting excavators and sometimes tracked shovels to recover soils from storage mounds in combination with dump trucks to transport the soil to the replacement area. Top- and subsoil may be stored in separate mounds or in clearly defined parts of the same mound, in some circumstances where the topsoil can be easily recovered it may be laid over the subsoil.

In this soil handling option the mounds are either built as single 'tier' or as 'multi-tiers'. In the single tier only the excavator, and if used the bulldozer, traffic the soil surface of the mound. In the multi-tier, the mound is also trafficked by loaded dump trucks.

The suitability, advantages and disadvantages are discussed in Sheet B and are predetermined here by the circumstances and the decision to store the soils. The removal of soils from the store can cause additional compaction. The advantage of this model method is that it should minimize additional severe compaction of the soil as trafficking is minimized. However, where the soil has been stored in multi-tier mounds it is likely to be a need for decompaction treatment of the interface between the tiers where the dump trucks have trafficked during the excavation and loading operation.

MODEL METHODOLOGY

C.1 The timing of excavation of the soil storage mounds will be governed by the weather and soil conditions governing stripping (see Sheet A). Key operational points to minimize the risk of severe soil compaction and soil wetness are summarised in Boxes C.1 and C.2.

C.2 All machines must be in a safe and efficient working condition at all times. The machines are to only work when ground conditions enable safe and efficient operation. Otherwise the operation is to be suspended until suitable remedial measures can be put in place.

C.3 The trucks should enter the storage area and draw alongside the active excavation face. The

Box C.1 - To minimize compaction:

- The dump trucks should only operate on the 'basal'/non-soil layer, and their wheels must not on any circumstances run on to the soil in store
- The excavator should be the only machine to operate on the single tier soil mound
- The machines are to only work when ground conditions enable their efficient operation
- When excavating the multi-tier mounds, to avoid trafficking, a dozer can be used to push the upper tier down to the excavator avoiding the need for trucks trafficking on the mound otherwise excavate tier by tier starting with the uppermost with trafficking confined to the upper surface of the lower tier
- If severe compaction has been caused then measures are required to treat it before it is loaded into the trucks by the excavator 'digging' over the affected layer (see below and Sheet N).

Box C.2 - To minimize soil wetness and rewetting:

- The mound should be shaped to shed water before rainfall occurs whenever removal is suspended
- Measures are required to protect the face of the soil layer from ponding of water and maintain the basal layer in a condition capable of supporting dump trucks.

Box C.3 - Choice of Bucket Type

For hard /stony soils toothed buckets are needed. Where the mixing of soil layers at their interface is to be minimized, a bucket with a 'blade' is preferable where the soil is 'soft' and free of large stones or stone free.

Similarly, the choice of bucket type, whether it is a standard 'digging'/bulking or wide ditching type will depend on the soil strength and stoniness.

back-acting excavator is stand on top of the mound to load trucks (**Figure C.1**) using an appropriate bucket type (Box C.3). The mound is to be dug to the base before moving progressively back along its axis.

C.4 When excavating the multi-tier mounds, where possible, to avoid trafficking a low ground pressure bulldozer can be used to push the upper tier soil down to the excavator. This avoids the need for dump trucks trafficking on the mound. Otherwise excavate tier by tier starting with the uppermost with trafficking confined to the upper surface of the lower tier. Here the excavation should be at the same height of tiers as originally built so that the same surfaces are used for trafficking to build it are again used, so as to minimize further severe compaction (**Figure C.2**). Having removed the upper tier, the trafficked layer(s) must be decompacted. This can be achieved by progressively digging the surface, as described on Sheet N, in advance of loading the next layer. It is essential that the digging is effective and this needs to be checked before soil is loaded. The process is repeated for each soil tier.

C.5 Any exposed edges/surfaces should be shaped on the onset of rain during the day. All surfaces should be shaped to shed water at the end of each day.

C.6 Work should stop in wet conditions (Box C.4) with measures undertaken to prevent ponding at the base of the mound and on the basal layer. At the start of each day ensure there is no ponding on the basal layer and operating areas.

Operational Variation

C.7 Front loading tracked machines may be used to excavate single tier soil mounds provided that they only operate on the basal layer along with the dump trucks (**Figure C.3**).

Box C.4 - Rainfall Criteria:

- In light drizzle soil handling may continue for up to four hours unless the soils are already at/near to their moisture limit
- In light rain soil handling must cease after 15 minutes
- In heavy rain and intense showers, handling shall cease immediately

In all of the above, after rain has ceased, soil tests shall be applied to determine whether handling may re-start, provided that the ground is free from ponding and ground conditions are safe to do so.

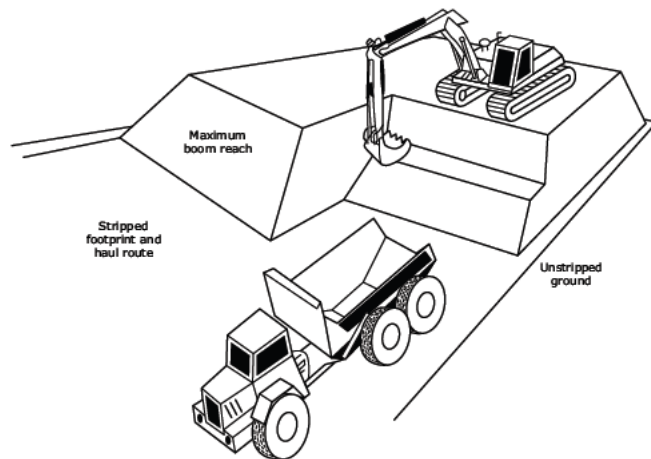

Figure C.1: Excavation of soil storage mounds with excavators and dump trucks: Single tier mounds.

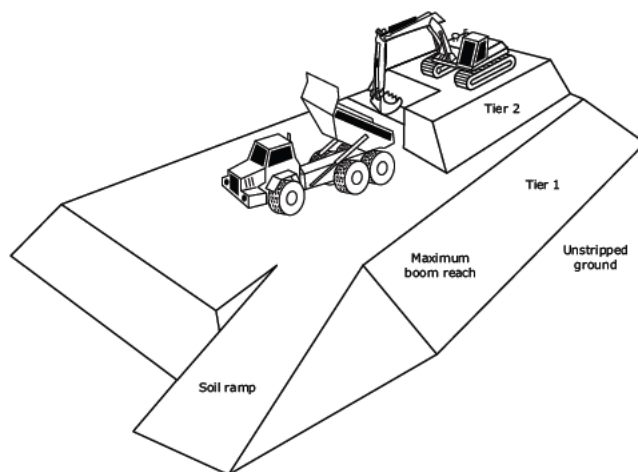

Figure C.2: Excavation of soil storage mounds with excavators and dump trucks: Multi tier mounds.

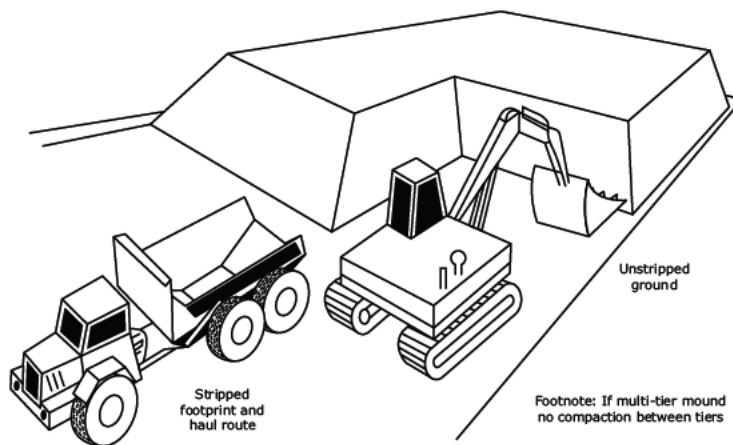

Figure C.3: Excavation of soil storage mounds with front loading shovels and dump trucks: Single and multi tier mounds.

GOOD PRACTICE GUIDE FOR HANDLING SOILS

In Mineral Workings

PART TWO: Model Methodology

- Sheet D -

Soil Replacement with Excavators and Dump Trucks
- Sequential Bed/Strip Practice

Author: Dr R N Humphries CBiol CSci FRSB FBSS FIQ
- Blakemere Consultants Ltd & Celtic Energy Ltd

Supporting artwork was provided by R Shelton (H J Banks & Co)
and D Fisher (Blue Room Graphics Ltd).

Preface

The purpose of Sheet D of the guidance is to provide a model method of best practice where excavators and dump trucks are to be used to replace soil using the sequential 'bed'/strip by strip practice.

The guidance is intended for use by planning officials, statutory consultees, mineral operators and their supporting teams and specialist consultants, and earth-moving contractors, their site supervisors and machine operators.

Successful soil handling schemes are dependent on the soil resources being clearly identified and the conditions in which they are to be handled. This information should be contained in the Soil Resource & Management Plan (SRMP) and communicated to those involved in its implementation.

Key issues to be addressed are:

- i) Avoiding conditions when soils are wet/ plastic during handling
- ii) The minimisation of soil compaction caused by trafficking and soil wetness
- iii) Using appropriate remedial treatments where these are necessary
- iv) Minimising soil loss, and mixing of soil layers or different soil types

The SRMP should specify the type of earth-moving machinery and soil handling practice, and the soil wetness condition (see Part One of the Guidance) to be deployed to achieve the planned after use, soil functioning, and the environmental and ecosystem services. It is to be communicated in full to all involved and in particular to the supervisors and machine operators by appropriate means; including tool-box talks and site demonstrations. Supervision by trained supervisory staff is essential, as are monitoring and reporting.

The guidance does not specify the size or model of equipment as this is left to the mineral operator and contractor to specify and provide. The machines must be of a kind which are appropriate for the task and the outcomes required, and to be able to carry out the work safely and efficiently.

Should the agreed methodology need to be modified or changed significantly, this should be agreed in advance with the mineral planning authority. The SRMP should include a mechanism whereby unexpected less significant changes can be quickly resolved through consultation between the operator, the planning authority and statutory consultee, and soil specialist.

All persons involved in the handling of soils must comply with all relevant legislation with respect to Health and Safety, in particular the Health and Safety at work Act 1974 and in the case of mineral extraction operations The Quarries Regulations 1999 and its relevant statutory provisions; in particular those aspects which relate to the construction and removal of tips, mounds and similar structures. These requirements take preference over any suggested practice in this Sheet and the SRMP should have taken these into account.

The users of this guidance are solely responsible for ensuring it complies with all safety legislation and good practice, including the manufacturer's specifications for the safe operation of the specific machines being used, and that all machines are in a good condition and well maintained and are suitable for the task. It is important that those involved in the operation of earth moving machines are competent and have the necessary training and certification.

Introduction

In this soil handling option, back-acting excavators are used to replace the soil resources tipped from dump trucks at the area being restored.

The replacement practice involves the sequential building up of the individual layers of soil identified in the Soil Resource & Management Plan (SRMP) as vertical slices through the soil profile and advancing as successive strips. Hence, the practice is often referred to as the 'Strip' or 'Bed' method.

The lower layer (subsoil) is placed first within the safe and efficient operational reach of the excavator boom which defines the width of each strip. For each subsequent soil layer, the process is repeated until the top layer (usually topsoil) is placed. When the soil resource/profile sequence within the strip is completely replaced, the process is repeated on the next strip to be replaced with soil and until the whole receiving area is completed. The following guidance can also be adopted where only a single soil horizon is to be replaced.

Unlike the stripping and storage practices, the replacement of soils is usually in concert with other work to remediate soil conditions such as compaction (**Sheets N & O**) and removal of stones/non-soil debris (**Sheets L & M**) to facilitate the intended after use, soil functions, and environmental and ecosystem service provisions. These actions have their own practices which need to be integrated into this model methodology of soil handling. The need for these will have been specified in the SRMP and/or in soil replacement conditions attached to the planning consent, or as determined by the soil specialist during the soil stripping/storage/replacement operations.

Advantages & Disadvantages

The advantages of this machinery combination and handling practice are:

- i) Provided the soils are not put into storage mounds, it is the most likely to result in soil profiles with the least compacted soils, which may not require remedial treatment or only minimal of action, as trafficking on the relayed soils is avoided
- ii) It can be easier to create localised changes

- iii) in soil types and variation in horizon depth It is suited both to the replacement of deep and uniform soils (including peat) as well as thin and 'patterned' soil layers
- iv) It is more flexible and quicker in responding to stoppages and restarts due to wet weather
- v) There is a greater certainty that a transpiring vegetation cover can be established during the soil replacement programme

The disadvantages are:

- i) That it requires greater supervision, skill and discipline in its deployment, and is best suited to experienced operators
- ii) Without good control and regular monitoring of soil layer depths, use of profile boards or machine fitted GPS it can be harder to gauge the rate of use of soil resource
- iii) There is a risk of some soil 'loss' and mixing of soil horizons at the exposed edges of multi-layered soils as the profile is built up
- iv) The bed system involving sequential remedial works may take longer to complete than other practices and machinery options
- v) Steep gradient/complex topographies may limit the safe and practical deployment of this handling practice

Suitability

The excavator-dump truck combination with the bed/strip handling practice methodology is considered 'best practice' by Natural England and the Welsh Government for agricultural soils and preferable for all soils. In particular, it is the most suitable of any of the methods available where:

- i) The soil is prone to compaction and where decompaction treatments cannot be relied upon to be effective
- ii) The intended after use, environmental and ecosystem services are dependent on soils maintaining their functional characteristics such as, porosity and hence drainage and aeration, plant available water capacity, and low resistance to plant root growth. This includes productive agricultural, horticultural and forestry land, many types of natural habitats, and where water storage/infiltration is of importance for the risk of flooding. Where the soils are stored prior

- to replacement some remedial treatment may have to be relied upon
- iii) As the bed/strip method offers the most flexibility in respect of short soil drying periods and likely wet weather, and can be less prone to delays and stoppages, it is particularly suited the wetter geographical locations
- iv) The full benefit of the practice for soils lies in their direct placement, this requires the mineral extraction scheme to be organized to minimize the need for soils storage.

MODEL METHODOLOGY

Basic Soil Replacement Operation

D.1 The following is the basic model methodology using excavators and dump trucks and the bed/strip practice. It is presented here, firstly without any remedial interventions to give clarity of the methodology. Further on the methodology is repeated to demonstrate how the interventions can be integrated in to the soil replacement process.

D.2 Key operational points to minimise the risk of severe soil compaction and soil wetness are summarised in Boxes D.1 and D.2.

D.3 The timing of soil handling operations in England and Wales is set out in **Part One, Supplementary Note 4**. For directly placed soils this will use the in situ soil wetness protocol for soil stripping operations to determine the timing for soil replacement (Box D.3). For soil that has been stored, the relaying operation should be governed by the weather (rainfall) criteria set out in Box D.4. Here, the operation will generally need to be completed no later than the end of September unless the establishment of a satisfactory vegetation cover can be assured.

D.4 Soil handling is not to take place during rain, sleet or snow and in these conditions should be prohibited if unsafe for machine operations. Prior to commencing operations, a medium/long term weather forecast should be obtained which gives reasonable confidence of soil handling being completed without significant interruptions from rainfall events. The soil based criteria set out in

Box D.1 - To minimise compaction:

- The dump trucks should only operate on the 'basal'/non-soil layer and not run on the replaced soil layer(s)
- The excavator must only operate on the basal layer
- The machines are to only work when ground conditions enable their efficient operation
- If compaction has been caused, then measures are required to treat it (see **Sheets N & O**).

Box D.2 - To minimise soil wetness and re-wetting:

- The bed/strip system provides a basis to regulate the exposure of lower soil layers to periods of rain and a means of maintaining soil moisture contents. The soil profile within the active strip should be completed including the topsoil layer before rainfall occurs and before replacement is suspended
- Measures are required to protect the face of the soil layer from ponding of water and maintain the basal layer in a condition capable of supporting dump trucks
- The area to be restored is to be protected from in-flow of water, ponding etc. Wet sites must be drained in advance. Before the operation starts the basal layer should be to level and clean.

Box D.4 are to be used to determine whether soil handling should cease or be interrupted with the occurrence of rain.

D.5 All machines must be in a safe and efficient working condition at all times. The machines are to only work when ground conditions enable their efficient operation. The work should only be carried out when the basal layer supports the machinery without ruts or is capable of repair/maintenance. Otherwise the operation is to be suspended until suitable remedial measures can be put in place.

D.6 The operation should follow the detailed SRMP replacement plan showing the soil units to be replaced, haul routes and the phasing of vehicle movements. The soil units should be defined on the site with information to distinguish types and layers,

Box D.3 - Test for Dry and Friable Soils

Soil tests are to be undertaken in the field. Samples shall be taken from at least five locations on the soil handling area and at each soil horizon to the full depth of the profile to be recovered/replaced. The tests shall include visual examination of the soil and physical assessment of soil consistency.

i) Examination

- If the soil is wet, films of water are visible on the surface of soil particles or aggregates (e.g. clods or peds) and/or when a clod or ped is squeezed in the hand it readily deforms into a cohesive 'ball' means **no soil handling to take place**
- If the sample is moist (i.e. there is a slight dampness when squeezed in the hand) but it does not significantly change colour (darken) on further wetting, and clods break up/crumble readily when squeezed in the hand rather than forming into a ball means **soil handling can take place**
- If the sample is dry, it looks dry and changes colour (darkens) if water is added, and it is brittle means **soil handling can take place**

ii) Consistency**First Test**

Attempt to mould soil sample into a ball by hand:

- Impossible because soil is too dry and hard or too loose and dry means soil handling can take place
- Impossible because the soil is too loose and wet means no soil handling to take place
- Possible - GO TO SECOND TEST

Second Test

Attempt to roll ball into a 3mm diameter thread by hand:

- Impossible because soil crumbles or collapses means **soil handling can take place**
- Possible means **no soil handling to take place**

NB: It is impossible to roll most coarse loamy and sandy soils into a thread even when they are wet. For these soils, the Examination Test alone is to be used.

Box D.4 - Rainfall Criteria:

- In light drizzle soil handling may continue for up to four hours unless the soils are already at/near to their moisture limit
- In light rain soil handling must cease after 15 minutes
- In heavy rain and intense showers, handling shall cease immediately

In all of the above, after rain has ceased, soil tests shall be applied to determine whether handling may re-start, provided that the ground is free from ponding and ground conditions are safe to do so.

and thickness and conveyed to the operational supervisor/operator. Different soil units to be kept separate are to be marked out and information to distinguish types and layers, and ranges of thickness needs to be conveyed to the operational supervisor/operator. Detailed daily records should be kept of operations undertaken and site and soil conditions.

D.7 The excavator and dump trucks are only to stand, work and travel on the basal/formation layer.

D.8 The soil layers above the base/formation layer are to be replaced in sequential strips with the sub-soil layer(s) replaced first, followed by the topsoil layer, each layer being replaced to the specified thickness. The next strip is not to be started until the profile in the current strip is completed. This is often referred to as the 'bed' or 'strip' system which involves the progressive sequential laying of the soil in strips across the area to be restored (**Figure D.1**).

D.9 The initial strip width and axis is to be demarcated. The strip width is determined by excavator boom length less the stand-off to operate; typically, about 3-4m (Box D.5). Excavators with long booms ('long reach') can be used, but may be more restricted by gradient limitations, and require skilled and experienced operators.

D.10 The preferred type of bucket to place the soils is usually a digging/bulking bucket with an attached blade or a wide ditching bucket, but a toothed

bucket can be used.

D.11 Profile boards should be used to control soil horizon thickness in each strip and overall levels achieved verified using soil pits. Allowances (i.e. a bulking factor) should be made for any settlement that may take place of the replaced loose soil.

Box D.5 - Orientation of the Excavator

Usually, the excavator is orientated and operates with its tracks at 90° to the axis of the bed being stripped as this is the most stable position. Whilst the reach of the boom and hence the width of the bed/strip can be significantly increased by orientating it with the tracks parallel to edge of the soil being spread, this may affect the stability of the excavator, particularly on a gradient or where the basal layer has a low bearing capacity. Hence, its safe deployment needs to be checked before its adoption.

D.12 The dump trucks reverse up to edge of the current strip and tip the lowest layer (subsoil) soil, without the wheels riding onto the strip (**Figure D.1**). The dump truck should not drive away until all the soil is deposited within the strip without spillage over the basal layer; this may require assistance from the excavator to 'dig away' some of the tipped soil (**Figure D.2**). The excavator is to spread the tipped soil to full thickness by digging, and using the pushing and pulling action of bucket.

D.13 Each load of soil should be spread following tipping before another is tipped. Should the spread soil comprise of large blocks (>300mm), normally these should be broken down by using the excavator bucket into smaller pieces before the next load is spread. The process is repeated until the strip is completely covered with the required depth of the soil layer (**Figure D.3**).

D.14 On completion of the lowest (subsoil) layer, repeat the process spreading the next layer (subsoil/topsoil) (**Figure D.4**). Tip the soil by reversing to the outer edge of strip/soil previously laid, but without the truck wheels riding onto the already placed layer (see Box D.6 for deep soil profiles). The soil is to be

spread by the excavator to full thickness by digging, and using the pushing and pulling action of bucket described above. Repeat the process progressively along the strip. Profile boards should be used to control the soil thickness in the strip and overall levels.

D.15 Where the profile is made up of further soil layers (subsoil/topsoil) the above process should be repeated on completion of the strip.

BOX D.6 - Soil Profiles Greater Than 1m Thickness

When the replaced soil profiles reach about 1m in height from the basal layer it may not be possible to discharge the load from smaller dump trucks directly onto the previously placed lower layers because of the height of the dump truck body. The preferred solution is to tip the soil against the partially completed profile as heaps without the dump trucks rising onto or reversing into the placed material. The soil material is then lifted by the excavator onto the profile. It is considered preferable to accept some limited soil losses rather than to contaminate the topsoil with overburden. The loss of top-soil is minimised if the basal/ formation layer is kept to level and clean.

D.16 On completion of topsoil layer, the processes outlined above should be repeated for the next strips until the area to be restored is completed. Before the operation starts the basal layer should be to level and cleared of any residual soil.

D.17 At the end of each day the current strip must be completed if rain is forecast. If during a day it is evident that a full strip cannot be completed, then complete the part of a strip that has been started.

D.18 At the end of each day, or during the day if interrupted by rain, make provisions to protect base of restored strip from ponding/runoff by sumps and grips, and also clean and level the basal layer. At the start of each day ensure there is no ponding in the current strip or operating areas, and the basal layer is to level with no ruts.

Method with Integration of Remedial Actions

D.19 Usually there should be less of a need for remedial treatment during the replacement operation with this machinery combination and handling practice (unless the soils were compacted during stripping or storage). Where compaction occurs, treatment will need to be integrated into the replacement process as will the need for the removal of stones or non-soil debris. Both decompaction and the removal of materials are covered in **Sheets L to O**. Where required, the early installation of under drainage can either be integrated sequentially during the replacement of the soils or later during the aftercare period.

D.20 The placement of the stripped soils in storage is likely to result in compaction and negate this particular benefit of the handling practice. Box D.7 sets out some of the remedial options/combinations to facilitate decompaction, and where necessary, the removal of stones and non-soil debris for a final profile comprising a basal layer, subsoil and topsoil layers. Except for Option 3, these actions need to be undertaken sequentially as each soil strip is placed.

D.21 The following is the model methodology integrating the remedial interventions within the bed/strip handling practice.

D.22 The key operational points to minimise the risk of severe soil compaction and soil wetness are summarised in the above Boxes 1 and 2.

D.23 Prior to commencing operations a weather forecast should be obtained which gives reasonable confidence of soil replacement proceeding without interruptions from rainfall events (Box D.4).

D.24 If significant rainfall occurs during operations, the replacement must be suspended, and where the soil profile has been started it should be replaced to topsoil level. Replacement should not restart unless the weather forecast is expected to be dry for at least a full day and the soils are in a dry condition (Box D.3).

D.25 The operation should follow the detailed replacement plan in the SRMP showing the soil units to be replaced, haul routes and the phasing

Box D.7 - Integration of Decompaction & Stone/Debris Removal

Option 1: is where the basal layer needs to be treated but is left until the subsoil is placed when both are decompacted together, followed by the decompaction of the topsoil and subsoil layers together (and basal layer) using tines that are long enough. This option is not suited to digging where the soil horizons would be mixed.

Option 2: is where each layer is treated separately by either tines or digging.

Option 3: is where the basal layer is treated or left untreated, followed by the placement of the subsoil and topsoil layers, which are to be decompacted by the use of tines. In the case of deep horizons this option can be limited by the capability of the machinery, the tines or bucket used. This option is not suited to digging where the soil horizons would be mixed.

of vehicle movements. The soil units should be defined on the site with information to distinguish types and layers, and thickness and conveyed to the operational supervisor/operator. Different soil units to be kept separate are to be marked out and information to distinguish types and layers, and ranges of thickness needs to be conveyed to the operational supervisor/operator. Detailed daily records should be kept of operations undertaken and site and soil conditions (including the removal of stones and other non-soil debris that needs to be removed), and the results of the effectiveness of the work undertaken, and any need for additional remedial treatments.

D.26 The excavator and dump trucks are only to stand, work and travel on the basal/formation layer. Only where the remedial work involves the use of a bulldozer does machinery have to traffic the soil surface being treated, as the excavators work from the basal layer.

D.27 The soil layers above the base/formation layer are to be replaced in sequential strips with the subsoil layer(s) replaced first, followed by the topsoil

layer; each layer being replaced to the specified thickness. The next strip is not to be started until the profile in the current strip is completed. This is often referred to as the 'bed' or 'strip' system which involves the progressive sequential laying of the soil in strips across the area to be restored (**Figure D.1**).

D.28 The initial strip width and axis is to be demarcated. Strip width is determined by excavator boom length less the stand-off to operate; typically, about 3-4m (see Box D.5).

D.29 The preferred type of bucket to place the soils is usually a digging/bulking bucket with an attached blade or a wide ditching bucket. However, where a bucket is being used to decompact soils, it should be a 'digging' type and have teeth or a stone-rake type with multiple tines is to be used.

D.30 Where there is a requirement to treat compaction and/or remove stones/damaging materials in the basal layer, these need to be carried out along the demarcated strip prior to the first layer of soils being laid.

D.31 Decompaction of the basal layer can be by digging with the excavator bucket or by bulldozer drawn tines (**Sheets N & O**). Stone removal may require prior ripping/digging to release them from the basal material, followed by the excavator using a stone-rake bucket (the stone to be loaded on a dump truck and removed (**Sheet L**)).

D.32 Profile boards should be used to control soil horizon thickness in each strip and overall levels achieved verified using soil pits to verify. Allowances (i.e. a bulking factor) should be made for any settlement that may take place of the replaced loose soil.

D.33 On completion, the loaded dump trucks reverse up to edge of the current strip and tip the lowest layer subsoil without the wheels riding onto the strip (**Figure D.1**). The dump truck should not drive away until all the soil is deposited within the strip without spillage over the basal layer; this may require assistance from the excavator to 'dig away' some of the tipped soil (**Figure D.2**). The excavator is to spread the tipped soil to full thickness by

digging, and using the pushing and pulling action of bucket.

D.34 Each load of soil should be spread following tipping before another is tipped. Should the spread soil comprise of large blocks (>300mm), normally these should be broken down by using the excavator bucket to break the blocks into smaller pieces before the next load is spread. The process is repeated from left to right until the strip is completely covered with the required depth of the soil layer (**Figure D.3**).

D.35 Where there is a requirement to treat compaction and/or remove stones/damaging materials in the subsoil layer, these need to be carried out along the demarcated strip prior to the next overlying layer of soils being laid. Decompaction can be by digging with the excavator bucket or by bulldozer drawn tines (**Sheets N & O**). Stone removal may require prior ripping/digging to release them from the soil (particularly if it is wet), followed by the excavator using a stone-rake bucket (to be loaded on a dump truck and removed (**Sheet L**)).

D.36 On completion of the lowest (subsoil) layer, repeat the process spreading the next layer (topsoil or upper subsoil) (**Figure D.4**). Where the profile is made up of further soil layers (subsoil/topsoil) the process outlined above should be repeated on completion of the strip. Tip the soil by reversing to the outer edge of strip/soil previously laid, but without the truck wheels riding onto the already placed layer (see Box D.6). The topsoil is to be spread by the excavator to full thickness by digging, and using the pushing and pulling action of bucket described above. Repeat the process progressively along the strip. Profile boards should be used and soil pits to verify soil thickness and overall levels in each strip.

D.37 Where there is a requirement to treat compaction in the topsoil layer within each strip as it is completed (see Box D.8), this can be by digging with the excavator bucket or by bulldozer drawn tines (**Sheets N & O**). If required, stone removal may require prior ripping/digging to release them from the soil clods, followed by the excavator using a stone-rake bucket (the stone to be loaded on a dump truck

and removed) (**Sheet L**).

D.38 On completion of the topsoil layer the processes outlined above should be repeated for the next strips until the whole area to be restored is completed. Before the operation starts the basal layer should be to level and clean.

D.39 At the end of each day the current strip must be completed if rain is forecast. If during a day it is

Box D.8

It is important that the decompaction and any stone/debris is removed from the topsoil layer as each strip is completed. Leaving it until the entire area is soiled will mean that the equipment, and in particular where the dump trucks collecting stones, have to traffic the soil surface resulting in compaction of the topsoil and the underlying subsoil.

Decompaction might be undertaken from the topsoil surface once the placing of the soils is completed (see **Sheet O**). However, this only advisable where it is certain that it will be effective and no other earth-moving machinery is to traffic the replaced soil and that soil wetness and weather conditions are suitable (see **Part One, Supplementary Notes 3 & 4**).

evident that a full strip cannot be completed, then complete the part of a strip that has been started.

D.40 At the end of each day, or during the day if interrupted by rain, make provisions to protect base of restored strip from ponding/runoff by sumps and grips, and also clean and level the basal layer. At the start of each day ensure there is no ponding in the current strip or operating areas, and the basal layer is to level with no ruts.

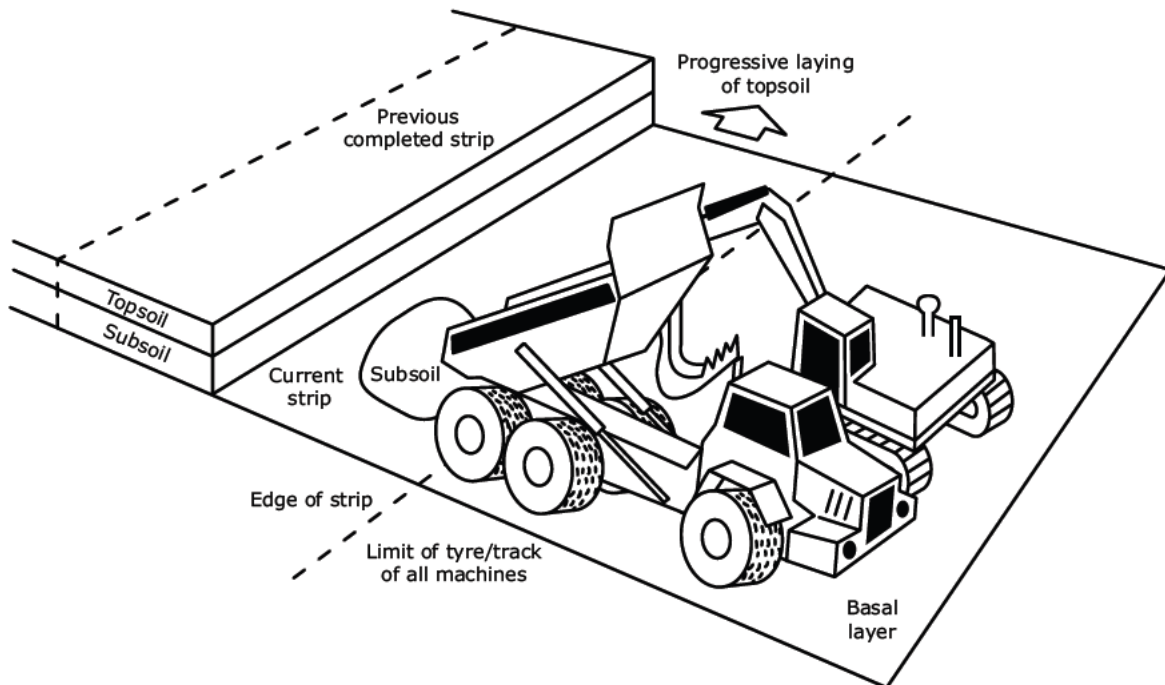

Figure D.1: Soil replacement with excavators and dump trucks: Subsoil layer.

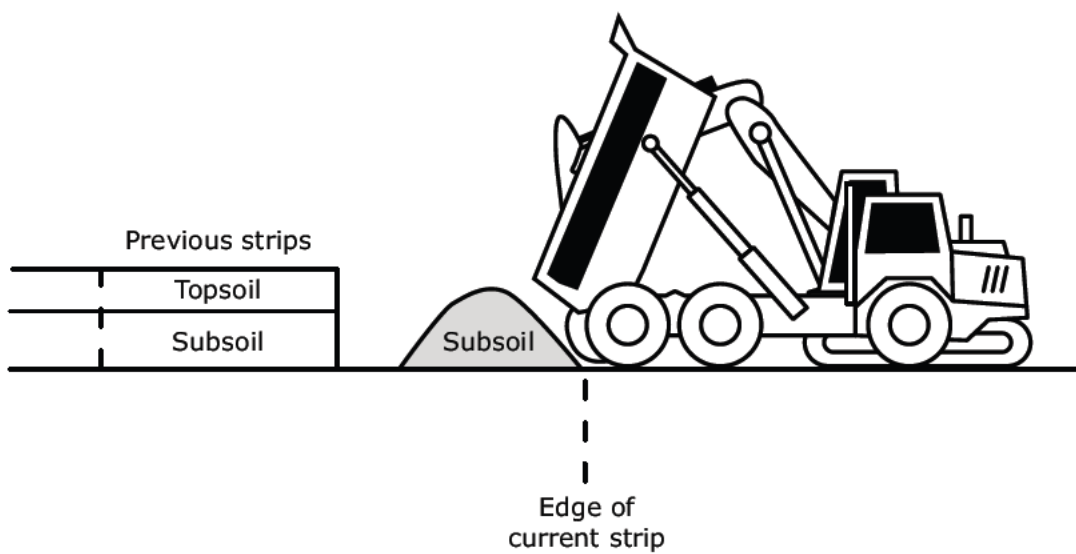

Figure D.2a: Soil replacement with excavators - dump trucks: Subsoil layer.

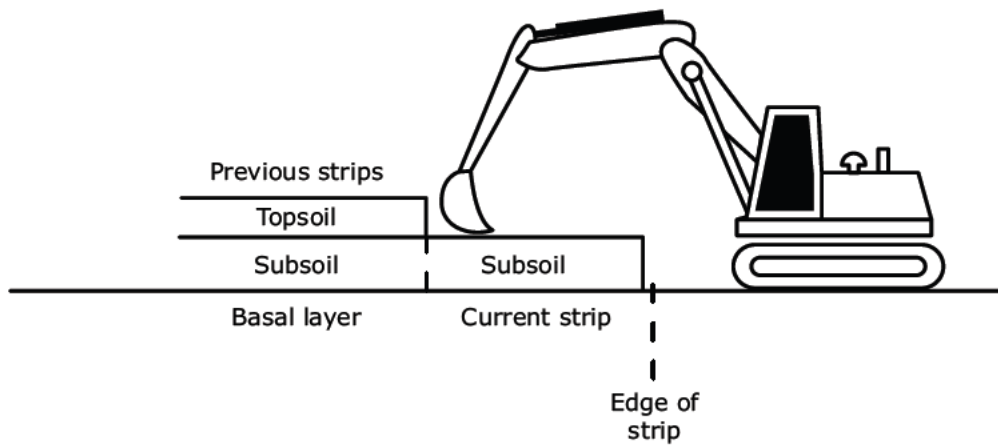

Figure D.2b: Soil replacement with excavators - dump trucks: Subsoil layer.

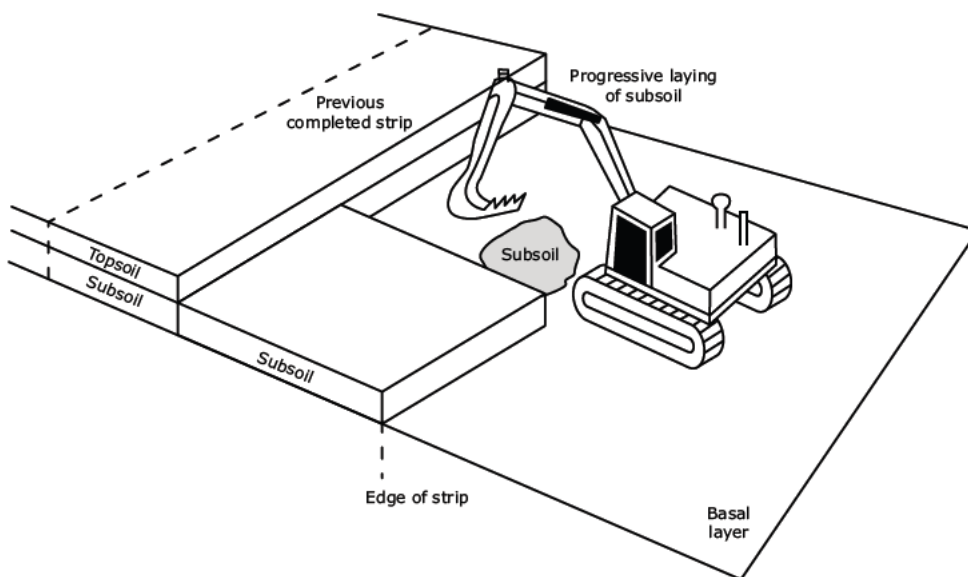

Figure D.3: Soil replacement with excavators and dump trucks: Subsoil progressively laid.

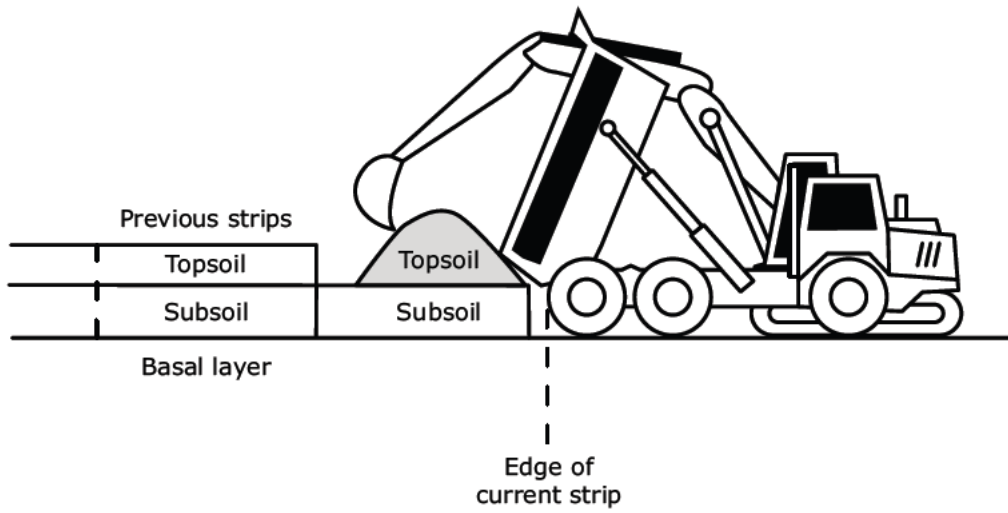

Figure D.4a: Soil replacement with excavators - dump trucks: Topsoil layer.

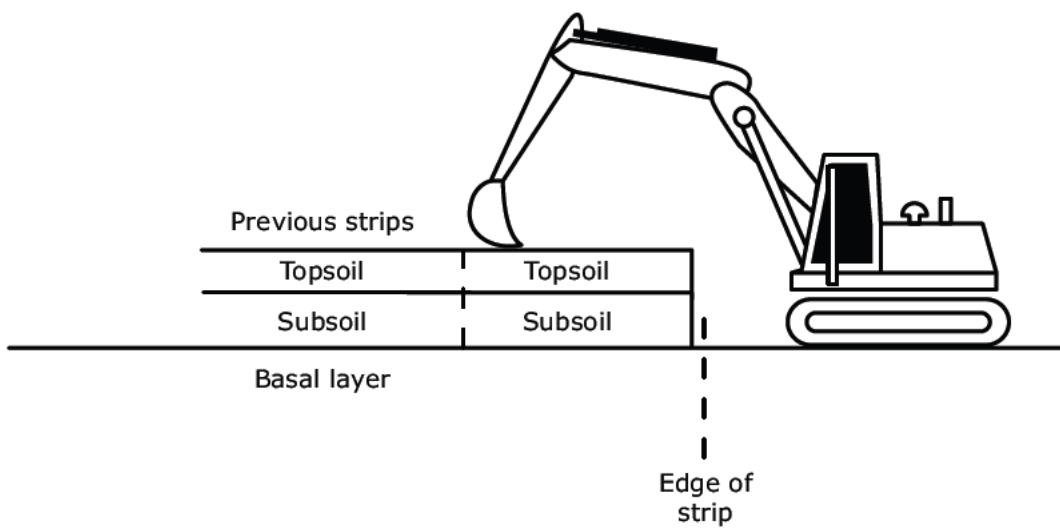

Figure D.4b: Soil replacement with excavators - dump trucks: Topsoil layer.

GOOD PRACTICE GUIDE FOR HANDLING SOILS

In Mineral Workings

PART TWO: Model Methodology

- Sheet E -

Soil Stripping with Excavators and Dump Trucks
- Windrow Practice

Author: Dr R N Humphries CBiol CSci FRSB FBSS FIQ
- Blakemere Consultants Ltd & Celtic Energy Ltd

Supporting artwork was provided by R Shelton (H J Banks & Co)
and D Fisher (Blue Room Graphics Ltd).

Preface

The purpose of Sheet E of the guidance is to provide a model method of best practice where excavators and dump trucks are to be used to strip soil using the windrow practice.

The guidance is intended for use by planning officials, statutory consultees, mineral operators and their supporting teams and specialist consultants, and earth-moving contractors, their site supervisors and machine operators.

Successful soil handling schemes are dependent on the soil resources being clearly identified and the conditions in which they are to be handled. This information should be contained in the Soil Resource & Management Plan (SRMP) and communicated to those involved in its implementation.

Key issues to be addressed are:

- i) Avoiding conditions when soils are wet/plastic during handling
- ii) The minimisation of soil compaction caused by trafficking and soil wetness
- iii) Using appropriate remedial treatments where these are necessary
- iv) Minimising soil loss, and mixing of soil layers or different soil types.

The SRMP should specify the type of earth-moving machinery and soil handling practice, and the soil wetness condition (see Part One of the Guidance) to be deployed to achieve the planned after use, soil functioning, and the environmental and ecosystem services. It is to be communicated in full to all involved and in particular to the supervisors and machine operators by appropriate means; including tool-box talks and site demonstrations. Supervision by trained supervisory staff is essential, as are monitoring and reporting.

The guidance does not specify the size or model of equipment as this is left to the mineral operator and contractor to specify and provide. The machines must be of a kind which are appropriate for the task and the outcomes required, and to be able to carry out the work safely and efficiently.

Should the agreed methodology need to be modified or changed significantly, this should be agreed in advance with the mineral planning authority. The SRMP should include a mechanism whereby unexpected less significant changes can be quickly resolved through consultation between the operator, the planning authority and statutory consultee, and soil specialist.

All persons involved in the handling of soils must comply with all relevant legislation with respect to Health and Safety, in particular the Health and Safety at work Act 1974 and in the case of mineral extraction operations, The Quarries Regulations 1999 and its relevant statutory provisions; in particular those aspects which relate to the construction and removal of tips, mounds and similar structures. These requirements take preference over any suggested practice in this Sheet and the SRMP should have taken these into account.

The users of this guidance are solely responsible for ensuring it complies with all safety legislation and good practice, including the manufacturer's specifications for the safe operation of the specific machines being used, and that all machines are in a good condition and well maintained and are suitable for the task. It is important that those involved in the operation of earth moving machines are competent and have the necessary training and certification.

Introduction

In this soil handling option, back-acting excavators are used to lift the soil resources gathered in ‘windrows’ and load them into dump trucks for the direct transport to an area being restored or to storage until needed.

The windrow stripping practice, sometimes referred to as the ‘peninsular’ method, involves the sequential separation and removal of the individual layers of soil identified in the Soil Resource & Management Plan (SRMP). The area to be stripped is divided into spaced parallel strips (windrows) where the soil between them is pulled from each side onto the strip acting as temporary repositories. The safe and efficient operational reach of the excavator boom defines the width between the windrows. The topsoil on the retreating surcharged windrows is then loaded systematically into the dump trucks by the excavator retreating towards the loading point on the haul route. On completing the removal of the topsoil, the exposed subsoil layer(s) is then recovered by the same procedure. The practice of stripping all the top-soil layer before starting the lower soil layers should be avoided as it increases the risk of rainfall events causing longer stoppages. The following guidance can also be adopted where only a single surface soil horizon is to be stripped.

Advantages & Disadvantages

The advantages of this machinery combination and handling practice are that:

- i) It is a relatively simple operation to undertake and can be quicker than the bed/strip practice
- ii) It can result a lower risk of severe compaction than the soil layer by layer practice, provided the soil is in a dry condition
- iii) If the soil horizons are stripped sequentially for each windrow, it offers flexibility in respect of short soil drying periods and likely wet weather as it is less susceptible to stoppages due to soil rewetting as a transpiring vegetation cover can be retained later into the stripping programme. Hence, it can be suited to northern and western, and

upland locations, and particularly when there are uncertain weather patterns.

The disadvantages are:

- i) Its beneficial effect is dependent on all the soil horizons being stripped as windrows, which may make it a slower more involved operation than the soil layer by layer practice
- ii) It requires skill and discipline, and a high level of supervision in its deployment, being suited to experienced operators
- iii) Whilst it can result in less soil compaction than other methods, it is likely some will be caused by the excavator moving on the soil during the formation of and operation of the windrows, and hence, there may be reliance on subsequent remedial treatment
- iv) Steep gradient/complex topographies may limit the safe and practical deployment of this machinery combination and handling practice.

Suitability

As the methodology involves the excavator operating on each layer of soils to form the successive windrows, there is a risk that compaction can occur and the likely reliance on remedial treatment with this practice. Hence, it is considered to be a less suitable practice than the bed/strip practice for minimizing the risk of soil compaction. The full benefit of the practice lies in the direct placement of the stripped soil and therefore requires the mineral extraction scheme to be organized to provide for this and minimize the need for soils storage.

Whilst it is not considered to be the ‘best practice’, the windrow practice may be acceptable in circumstances such as where there is a medium to high soil resilience to compaction (see **Table 7, Part One**) or the best available where:

- i) The soil profile in each designated windrow is stripped sequentially to the basal layer before progressing to the next
- ii) The dump trucks do not run on the in situ and the windrowed soils
- iii) It is used to recover a single surface soil layer
- iv) The intended after use, and environmental

and ecosystem services are less dependent on maintaining their full functional characteristics such as porosity and hence drainage and aeration, plant available water capacity, and low resistance to plant root growth. This may include the less productive agricultural and forestry land, many types of natural habitats, and where water storage/infiltration is of lesser importance for the risk of flooding. Where the soils are stored prior to replacement, effective remedial treatment may have to be relied upon

v) It is not suitable for soils with a low bearing capacity such as peat or organic soils, or soils having a high water table

vi) It is often considered to be the most suitable of the soil stripping practices available for important archaeological sites (see Box E.1).

MODEL METHODOLOGY

E.1 Key operational points to minimize the risk of severe soil compaction and soil wetness are summarised in Boxes E.2 and E.3.

Box E.1

Stripping soils in windrows with an excavator is often the preferred practice when archaeological investigations and recording (as opposed to trial pit/trench sampling and 'watching briefs') are required as part of a planning consent. However, there may be a need for a deviation from normal good practice for soils with the excavator and dump trucks trafficking over the topsoil layer used as the haul route, and in some cases the surcharging of the topsoil for further protection of the archaeological feature. In these cases compaction of the topsoil will result and remedial treatment will have to be relied upon.

Box E.2 - To minimize compaction:

- The dump trucks should normally only operate on the 'basal'/non-soil layer, and their wheels must not run on to the soil layer(s)
- The excavator only operates on the windrow with the dump trucks only travelling on the basal layer
- The machines are to only work when ground conditions enable their efficient operation
- The topsoil to be surcharged on the windrow as a thick layer as possible whilst maintaining the safe operation
- The soil layers are to be in 'dry' condition.

Box E.3 - To minimize the wetness of the soil and re-wetting of the soil:

- The progressive windrow system provides a basis to regulate the exposure of lower soil layers to periods of rain and a means of maintaining soil moisture contents. The soil profile within the active windrowed strip should be removed to the basal layer before rainfall occurs and before stripping is suspended
- Measures are required to protect the exposed face of the soil layer from ponding of water and maintain the basal layer in a condition capable of supporting dump trucks
- The area to be stripped is to be protected from in-flow of water, ponding etc. Wet sites should be drained in advance
- The maintenance of a transpiring crop is important, and an appropriate cropping regime should be established for the year of soil stripping
- Before stripping, excess vegetation should be removed; in the case of grassland it should be cut or grazed short and arable crops should have been harvested.

E.2 The timing of soil handling operations should only take place when the soils are in a 'dry and friable' condition (ie when it breaks and shatters when disturbed rather than smears and deforms) (see **Part One, Supplementary Note 4**). Prior to the start or recommencement of soil handling they should be tested to confirm they are in suitably dry condition (see Box E.4).

E.3 Soil handling is not to take place during rain, sleet or snow and in these conditions should be prohibited due to unsafe machine operating conditions. Prior to commencing operations, a medium/long term weather forecast should be obtained which gives reasonable confidence of soil handling being completed without significant interruptions from rainfall events. The soil based criteria set out in Box E.5 are to be used to determine whether soil handling should cease or be interrupted with the occurrence of rain.

E.4 All machines must be in a safe and efficient working condition at all times. The machines are to only work when ground conditions enable safe and efficient operation. Otherwise the operation is to be suspended until suitable remedial measures can be put in place.

E.5 The operation should follow the detailed stripping plan set out in the SRMP showing soil units to be stripped, haul routes and the phasing of vehicle movements. Different soil units to be kept separate are to be marked out and information to distinguish types and layers, and ranges of thickness needs to be conveyed to the operational supervisor/operator. The haul routes and soil storage areas must be defined and should be stripped first in a similar manner. Detailed daily records should be kept of operations undertaken, and site and soil conditions.

E.6 Within each soil unit the soil layers above the base/formation layer are to be stripped in sequential strips with the topsoil layer stripped first, followed by the subsoil layers; each layer stripped to its natural thickness without incorporating material from the lower layers. To protect the subsoil from becoming wet during changes in the weather, the next windrowed topsoil strip should not be started

Box E.4 - Test for Dry and Friable Soils

Soil tests are to be undertaken in the field. Samples shall be taken from at least five locations on the soil handling area and at each soil horizon to the full depth of the profile to be recovered/replaced. The tests shall include visual examination of the soil and physical assessment of soil consistency.

i) Examination

- If the soil is wet, films of water are visible on the surface of soil particles or aggregates (e.g. clods or peds) and/or when a clod or ped is squeezed in the hand it readily deforms into a cohesive 'ball' means **no soil handling to take place**
- If the sample is moist (i.e. there is a slight dampness when squeezed in the hand) but it does not significantly change colour (darken) on further wetting, and clods break up/crumble readily when squeezed in the hand rather than forming into a ball means **soil handling can take place**
- If the sample is dry, it looks dry and changes colour (darkens) if water is added, and it is brittle means **soil handling can take place**

ii) Consistency

First Test

Attempt to mould soil sample into a ball by hand:

- Impossible because soil is too dry and hard or too loose and dry means soil handling can take place
- Impossible because the soil is too loose and wet means no soil handling to take place
- Possible - GO TO SECOND TEST

Second Test

Attempt to roll ball into a 3mm diameter thread by hand:

- Impossible because soil crumbles or collapses means **soil handling can take place**
- Possible means **no soil handling to take place**

NB: It is impossible to roll most coarse loamy and sandy soils into a thread even when they are wet. For these soils, the Examination Test alone is to be used.

until the subsoil under lying the strip is completely stripped to the basal layer (**Figure E.1**). Stripping is to be undertaken by the excavator standing within the windrow strip and loading the surcharged soil layer into dump trucks.

Box E.5 - Rainfall Criteria:

- In light drizzle soil handling may continue for up to four hours unless the soils are already at/near to their moisture limit
- In light rain soil handling must cease after 15 minutes
- In heavy rain and intense showers, handling shall cease immediately

In all of the above, after rain has ceased, soil tests shall be applied to determine whether handling may re-start, provided that the ground is free from ponding and ground conditions are safe to do so.

Box E.6 - Choice of Bucket Type

For hard /stony soils toothed buckets are needed. Where the mixing of soil layers at their interface is to be minimized, a bucket with a 'blade' is preferable where the soil is 'soft' and free of large stones or particularly stony stone free.

Similarly, the choice of bucket type, whether it is a standard 'digging'/bulking or wide ditching type will depend on the soil strength and stoniness.

Bladed buckets will be required for soil stripping involving archaeological investigation. Where there is a watching archaeological brief, the use of bladed buckets will normally be required.

E.7 The type of bucket to be used largely depends on the nature of the soil (Box E.6).

E.8 Demarcate the windrow topsoil strips to be surcharged; the width of the soil strip to be recovered between the windrows is determined by the effective and safe excavator boom radius from the edge of each windrow; typically, about 3-4m (Box E7). Excavators with long booms ('long reach') can be used, but may be more restricted by gradient

Box E.7 - Orientation of the Excavator

Usually, the excavator is orientated and operates with its tracks at 90° to the axis of the bed being stripped as this is the most stable position.

Whilst the reach of the boom and hence the width of the bed/strip can be significantly increased and the excavator trafficking over the soil surface decreased by orientating it with the tracks parallel to edge of the soil being stripped, this may affect the stability of the excavator, particularly on a gradient or where soils have a low bearing capacity. Hence, its safe deployment needs to be checked before its adoption.

limitations, and require skilled and experienced operators.

E.9 The excavator is only to stand and work on the soil layers when stripping soils, otherwise it is to travel only on the basal/formation layer. The dump trucks are only to operate on the basal/formation layer. The exception is where it is stipulated that they are to traffic the topsoil for the protection of underlying archaeological features (see above Box E.1).

E.10 The top-soil layer is to be pulled up in the thickest layer possible onto the surcharged strip (**Figures E.1 & E.2**). It should be recovered to the full width of the segment being stripped without mixing with the underlying subsoil (not more than 20% of the lower horizon should be exposed at the layer junction within the strip). The thickness and identification of the horizon junction must be verified before and during stripping. The full thickness of the topsoil horizon should be stripped progressively before the underlying subsoil horizon(s), if present, is to be started. On completion of the topsoil windrow and its removal, the above procedures are repeated sequentially for each underlying soil horizon until the area is completely stripped of soil to the basal layer (**Figures E.3 & E.4**).

E.11 Where the soils are to be directly placed without storage in mounds, the initial strip of the upper horizons will have to be stored temporarily to

release the lowest layer and enable the sequential movement of materials.

The stored initial soil material would be placed on the lower layer removed from the final strip at the end of the programme or on partially completed profiles if rain were forecast.

E.12 When the stripping operation is likely to be interrupted by rain or there is likely to be overnight rain remove any exposed subsoil down to the basal layer before suspending operations. Make provisions to protect base of current or next strip from ponding/runoff by sumps and grips, and also clean and level the basal layer. At the start of each day ensure there is no ponding in the current strip or operating areas, and the basal layer is to level with no ruts.

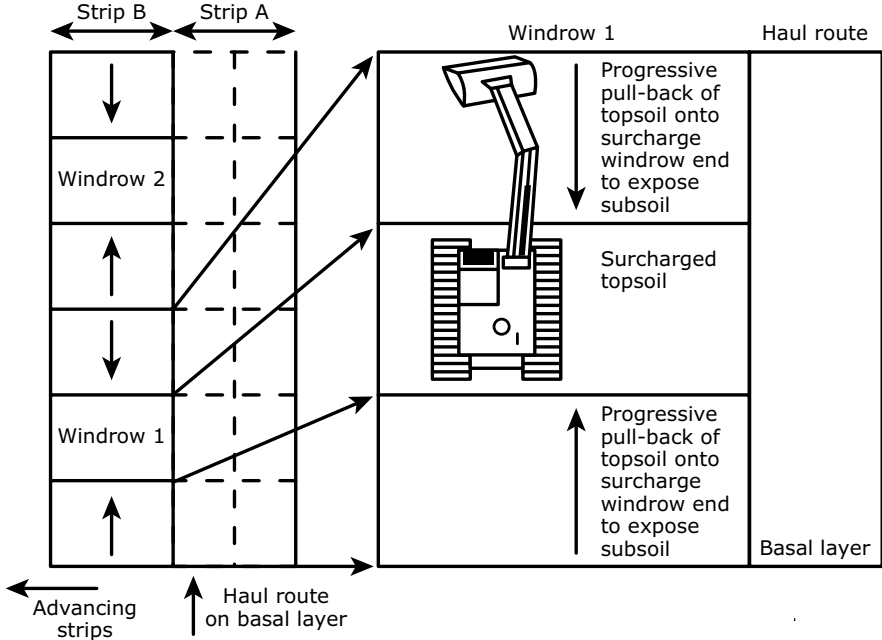

Figure E.1: Surcharging of windrow with topsoil.

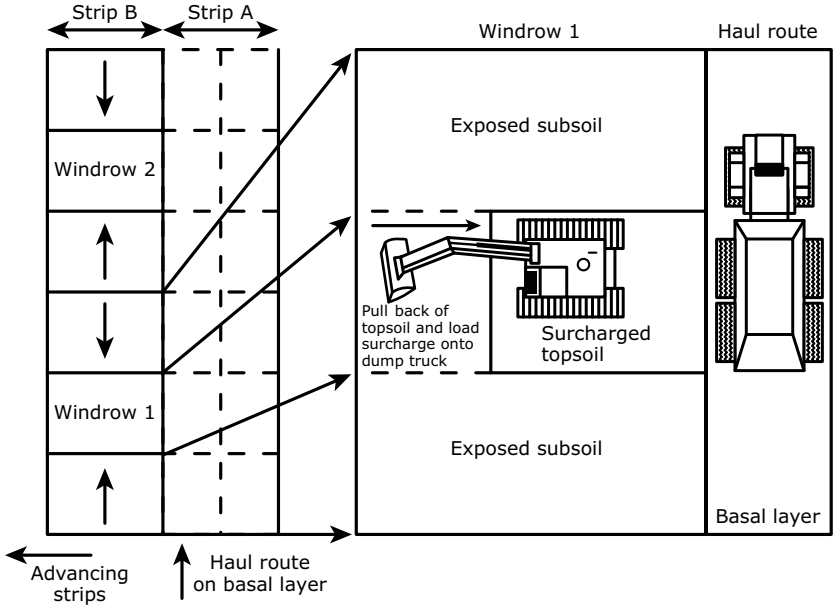

Figure E.2: Retreat of topsoil, surcharged windrow and loading of dump trucks.

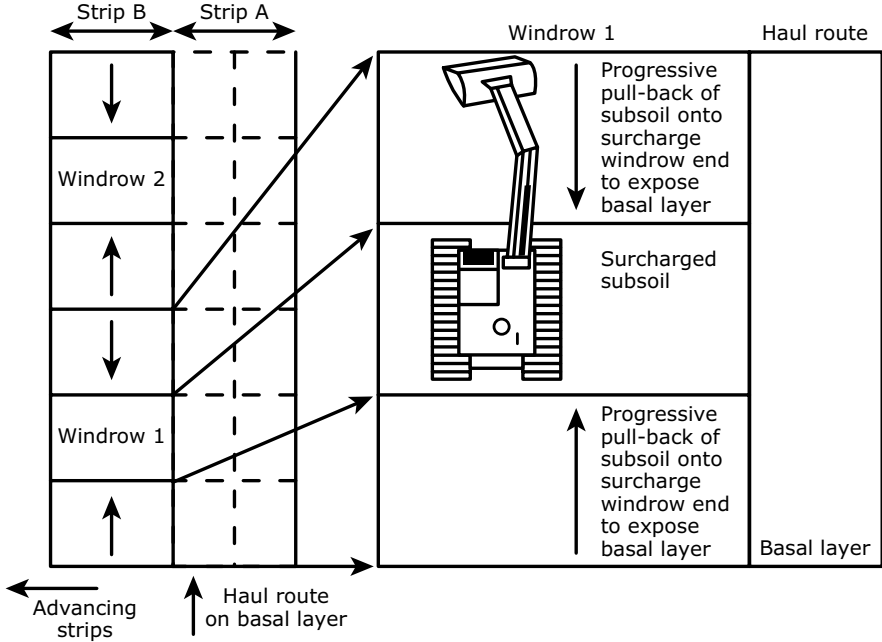

Figure E.3: Surcharging of windrow with subsoil.

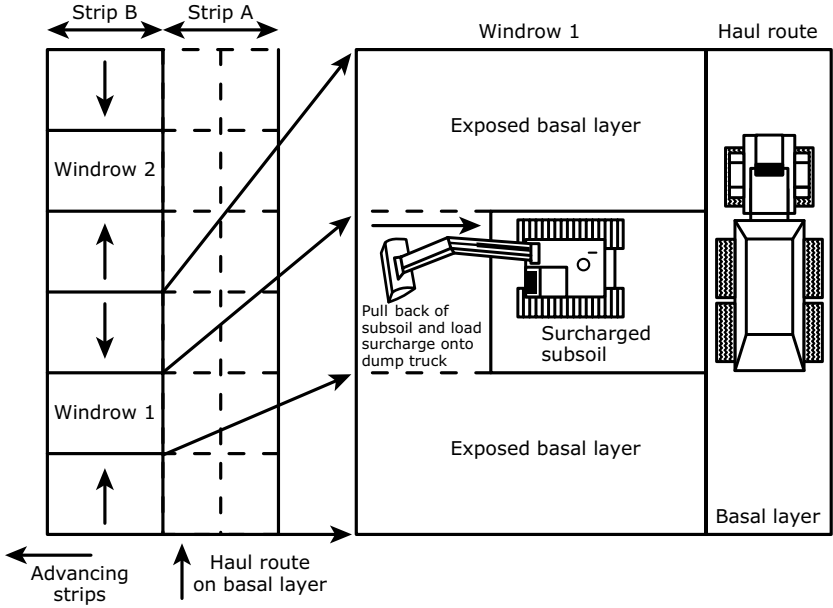

Figure E.4: Retreat of subsoil surcharged windrow and loading of dump trucks.

GOOD PRACTICE GUIDE FOR HANDLING SOILS

In Mineral Workings

PART TWO: Model Methodology

- Sheet F -

Soil Stripping with Bulldozers and Dump Trucks
- Windrow Practice

Author: Dr R N Humphries CBiol CSci FRSB FBSSS FIQ
- Blakemere Consultants Ltd & Celtic Energy Ltd

Supporting artwork was provided by R Shelton (H J Banks & Co)
and D Fisher (Blue Room Graphics Ltd).

Preface

The purpose of Sheet F of the guidance is to provide a model method of best practice where bulldozers and dump trucks are to be used to strip soil using the windrow practice.

The guidance is intended for use by planning officials, statutory consultees, mineral operators and their supporting teams and specialist consultants, and earth-moving contractors, their site supervisors and machine operators.

Successful soil handling schemes are dependent on the soil resources being clearly identified and the conditions in which they are to be handled. This information should be contained in the Soil Resource & Management Plan (SRMP) and communicated to those involved in its implementation.

Key issues to be addressed are:

- i) Avoiding conditions when soils are wet/plastic during handling
- ii) The minimisation of soil compaction caused by trafficking and soil wetness
- iii) Using appropriate remedial treatments where these are necessary
- iv) Minimising soil loss, and mixing of soil layers or different soil types.

The SRMP should specify the type of earth-moving machinery and soil handling practice, and the soil wetness condition (see Part One of the Guidance) to be deployed to achieve the planned after use, soil functioning, and the environmental and ecosystem services. It is to be communicated in full to all involved and in particular to the supervisors and machine operators by appropriate means; including tool-box talks and site demonstrations. Supervision by trained supervisory staff is essential, as are monitoring and reporting.

The guidance does not specify the size or model of equipment as this is left to the mineral operator and contractor to specify and provide. The machines must be of a kind which are appropriate for the task and the outcomes required, and to be able to carry out the work safely and efficiently.

Should the agreed methodology need to be modified or changed significantly, this should be agreed in advance with the mineral planning authority. The SRMP should include a mechanism whereby unexpected less significant changes can be quickly resolved through consultation between the operator, the planning authority and statutory consultee, and soil specialist.

All persons involved in the handling of soils must comply with all relevant legislation with respect to Health and Safety, in particular the Health and Safety at work Act 1974 and in the case of mineral extraction operations, The Quarries Regulations 1999 and its relevant statutory provisions; in particular those aspects which relate to the construction and removal of tips, mounds and similar structures. These requirements take preference over any suggested practice in this Sheet and the SRMP should have taken these into account.

The users of this guidance are solely responsible for ensuring it complies with all safety legislation and good practice, including the manufacturer's specifications for the safe operation of the specific machines being used, and that all machines are in a good condition and well maintained and are suitable for the task. It is important that those involved in the operation of earth moving machines are competent and have the necessary training and certification.

Introduction

In this soil handling option, bulldozers are used to strip the soil by heaping it into ‘windrows’, and back-acting excavators are used to load them into dump trucks for the direct transport to an area being restored or to storage until needed.

The windrow stripping practice, sometimes referred to as the ‘peninsular’ method, involves the sequential separation and removal of the individual layers of soil identified in the Soil Resource & Management Plan (SRMP). The area to be stripped is divided into spaced out parallel longitudinal strips (windrows) where alternative strips of topsoil from each side is pushed to surcharge the windrows acting as temporary repositories. The safe and efficient distance of the bulldozer’s push defines the width between the windrows. The topsoil on the retreating surcharged strips is then loaded by excavator into the dump trucks at the loading point on the haul route. On completing, the removal of the windrow the process is repeated for the next topsoil area to be stripped. The process using bulldozers is usually repeated across the area to be stripped of soils until all the topsoil layer is completely removed. Whilst the exposed subsoil layer, if present and to be recovered, can be by the same procedure of windrowing the common and more practical practice is the sequential lifting of the subsoil by the excavator with the trafficking and loading of dump trucks on the basal layer. The following guidance can also be adopted where only a single soil horizon is to be stripped.

Advantages & Disadvantages

The advantage of this machinery combination and handling practice are that:

- i) It is a relatively simple operation to undertake and can be quicker than both the excavator combination with the bed/strip and windrow practices.

The disadvantages are several:

- i) There is risk of compaction of the top- and subsoil layers by the repeated trafficking of the bulldozer, even if a low ground pressure machine is used, as it pushes soil to the windrows. Hence, subsequent remedial treatments are likely to be relied

- ii) upon
It is susceptible to stoppages due to soil rewetting as the transpiring vegetation cover is removed on stripping the topsoil
- iii) It is slow react to localised changes in soil types and variation in horizon depth, and can result in the mixing of soil horizons
- iv) It is not suited to the stripping of thin and ‘patterned’ soil layers, and cleanly exposing the top-sub-soil interface.

Suitability

This handling practice is not suitable where the subsoil surface needs to be carefully exposed for archaeological investigations and recording (as opposed to trial sampling).

Whilst the method is not considered ‘best practice’, it may be acceptable in circumstances where:

- i) The subsoil(s) have a high resilience to further compaction (see **Table 7, Part One**) and when decompaction treatments can be more relied upon to be effective because of a low risk of soil wetness (low rainfall areas/ prolonged dry conditions) or operational limitations (such as the availability of effective decompaction tools)
- ii) The intended after use, and environmental and ecosystem services are less dependent on maintaining functional characteristics such as soil porosity and hence drainage and aeration, plant available water capacity, and low resistance to plant root growth. This may include low productivity agricultural and forestry land, some types of natural habitats, and where water storage/infiltration is of lesser importance for the risk of flooding. Where the soils are stored prior to replacement, effective remedial treatment may have to be relied upon.
- iii) The soils are placed into storage stockpiles.

MODEL METHODOLOGY

F.1 Key operational points to minimize the risk of severe soil compaction and soil wetness are summarised in Boxes F.1 and F.2.

Box F.1 - To minimize compaction:

- The dump trucks should normally only operate on the 'basal layer, and their wheels must not in any circumstances run on to the soil layer(s)
- The machines are to only work when ground conditions enable their efficient operation
- The soils are to be stripped by the bulldozer in as thick layer as possible whilst maintaining their efficient operation
- The bulldozer should make the minimal number of passes over the soil as possible
- The soil layers are to be in 'dry' condition.

Box F.2 - To minimize the wetness of the soil and re-wetting of the soil:

- The windrow system provides a basis to regulate the exposure of lower soil layers to periods of rain and a means of maintaining soil moisture contents. The soil profile within the active strip should be stripped to the basal layer before rainfall occurs and before stripping is suspended
- Measures are required to protect the face of the soil layer from ponding of water and maintain the basal layer in a condition capable of supporting dump trucks
- The area to be stripped is to be protected from in-flow of water, ponding etc. Wet sites should be drained in advance
- The maintenance of a transpiring crop is important, and an appropriate cropping regime should be established for the year of soil stripping
- Before stripping, excess vegetation should be removed; in the case of grassland it should be cut or grazed short and arable crops should have been harvested.

F.2 The timing of soil handling operations should only take place when the soils are in a 'dry and friable' condition (ie when it breaks and shatters when disturbed rather than smears and deforms) (see Part One, Supplementary Note 4). Prior to the start or recommencement of soil handling they should be tested to confirm they are in suitably dry condition (see Box F.3).

Box F.3 - Test for Dry and Friable Soils

Soil tests are to be undertaken in the field. Samples shall be taken from at least five locations on the soil handling area and at each soil horizon to the full depth of the profile to be recovered/replaced. The tests shall include visual examination of the soil and physical assessment of soil consistency.

i) Examination

- If the soil is wet, films of water are visible on the surface of soil particles or aggregates (e.g. clods or peds) and/or when a clod or ped is squeezed in the hand it readily deforms into a cohesive 'ball' means **no soil handling to take place**
- If the sample is moist (i.e. there is a slight dampness when squeezed in the hand) but it does not significantly change colour (darken) on further wetting, and clods break up/crumble readily when squeezed in the hand rather than forming into a ball means **soil handling can take place**
- If the sample is dry, it looks dry and changes colour (darkens) if water is added, and it is brittle means **soil handling can take place**

ii) Consistency**First Test**

Attempt to mould soil sample into a ball by hand:

- Impossible because soil is too dry and hard or too loose and dry means soil handling can take place
- Impossible because the soil is too loose and wet means no soil handling to take place
- Possible - GO TO SECOND TEST

Second Test

Attempt to roll ball into a 3mm diameter thread by hand:

- Impossible because soil crumbles or collapses means **soil handling can take place**
- Possible means **no soil handling to take place**

NB: It is impossible to roll most coarse loamy and sandy soils into a thread even when they are wet. For these soils, the Examination Test alone is to be used.

F.3 Soil handling (by any machinery combination and handling practice) is not to take place during rain, sleet or snow and in these conditions should be prohibited due to unsafe machine operating conditions. Prior to commencing operations a medium/long term weather forecast should be obtained which gives reasonable confidence of soil handling being completed without significant interruptions from rainfall events. The soil based criteria set out in Box F.4 are to be used to determine whether soil handling should cease or be interrupted with the occurrence of rain.

Box F.4 - Rainfall Criteria:

- In light drizzle soil handling may continue for up to four hours unless the soils are already at/near to their moisture limit
- In light rain soil handling must cease after 15 minutes
- In heavy rain and intense showers, handling shall cease immediately.

In all of the above, after rain has ceased, soil tests shall be applied to determine whether handling may re-start, provided that the ground is free from ponding and ground conditions are safe to do so.

F.4 All machines must be in a safe and efficient working condition at all times. The machines are to only work when ground conditions enable safe and efficient operation. Otherwise the operation is to be suspended until suitable remedial measures can be put in place.

F.5 The operation should follow the detailed stripping plan set out in the SRMP showing soil units to be stripped, haul routes and the phasing of vehicle movements. Different soil units to be kept separate are to be marked out and information to distinguish types and layers, and ranges of thickness needs to be conveyed to the operational supervisor/operator. The haul routes and soil storage areas must be defined and should be stripped first in a similar manner. Detailed daily records should be kept of operations undertaken, and site and soil conditions.

F.6 Demarcate an initial surcharged top-soil strip and the width of the recovered soil as the effective

push distance of the bulldozer to the edge of the windrow (BOX F.5).

BOX F.5

Whilst there can be a lower of a risk of compaction when using wide tracked ('low ground pressure' (LGP)) bulldozers, in some circumstances they may require to traffic the soil surface more than standard machines to achieve the same work rate, and therefore the advantage of their use may be less than anticipated. However, the risk of severe compaction and reliance on remedial treatments may be less with the use of LGP machines.

F.7 Within each soil unit the topsoil layer is to be stripped across the area in sequential windrowed strips; the topsoil stripped to its natural thickness without incorporating material from the lower layer. Stripping of the topsoil is to be undertaken by the bulldozer standing on the surface and pushing the soil at its maximum thickness onto the windrow where the excavator loads the surcharged soil into the dump truck.

F.8 The topsoil layer is to be pushed up onto the windrow in the thickest layer possible with the minimal passes possible, whilst maintaining operational efficiency of the bulldozer, to form the low mound (**Figure F.1**). The topsoil should be recovered to the full width of the segment without mixing with sub-soil (not more than 20% of the lower horizon should be exposed at the layer junction within the strip). The thickness and identification of the horizon junction must be verified before and during stripping.

F.9 The soil furthest from the windrowed strip should be pushed first, progressively working to the front of the strip (**Figure F.1**). The topsoil is to be loaded into the dump truck stood on the basal layer by the excavator on the surcharged windrow (**Figure F.2**).

F.10 Unless the area is being stripped in segments to maintain vegetation and vegetated top-soil cover to protect as the subsoils from rewetting, the full thickness of the topsoil horizon would be stripped progressively across the area before the subsoil horizon(s) is stripped.

F.11 The subsoil layer(s) is to be recovered by repeating the above process with the bulldozer pushing the subsoil onto the new windrow with the excavator standing on the subsoil and loading onto the dump truck on the basal layer (**Figures F.3 & F.4**).

F.12 Where there is an upper subsoil to be recovered, if possible it is to be stripped as a windrow in the above manner. The lower subsoil would be recovered by the normal progressive lifting and loading by excavator from the subsoil layer with the dump trucks on the basal layer.

F.13 Where the soils are to be directly replaced without storage in mounds, the initial strip of the upper horizons will have to be stored temporarily to release the lowest layer and enable the sequential movement of materials. The stored initial soil material would be placed on the lower layer removed from the final strip at the end of the programme or on partially completed profiles if rain was forecast.

F.14 Where the stripping operation is likely to be interrupted by rain or there is likely to be overnight rain remove any exposed subsoil down to the basal layer before suspending operations. Make provisions to protect base of current or next strip from ponding/runoff by sumps and grips, and also clean and level the basal layer. At the start of each day ensure there is no ponding in the current strip or operating areas, and the basal layer is to level with no ruts.

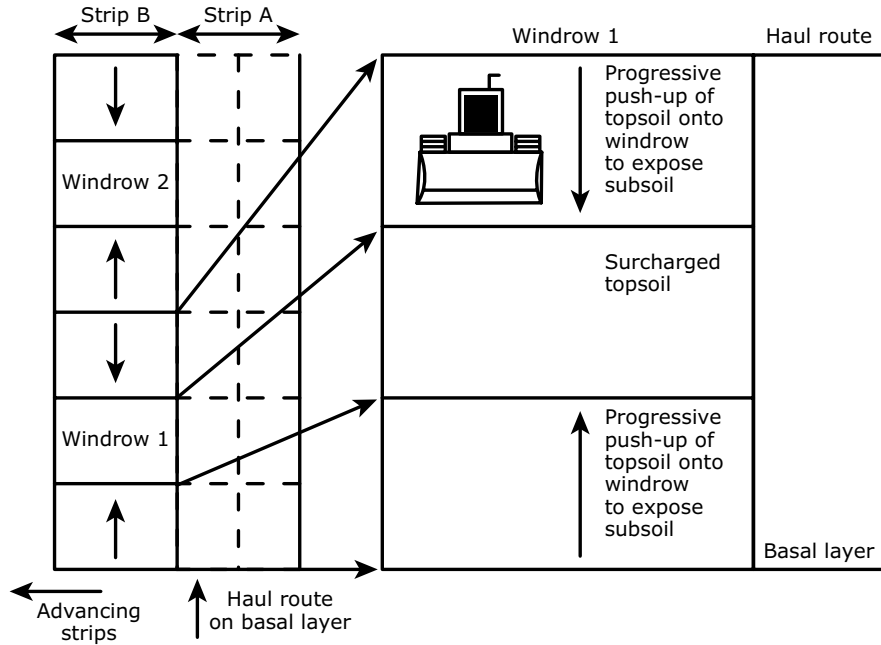

Figure F.1: Surcharging of windrow with topsoil.

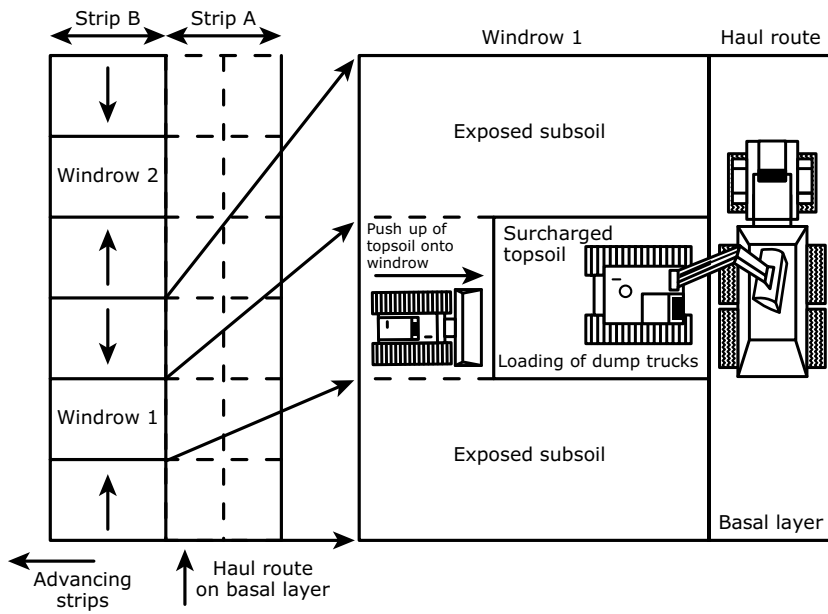

Figure F.2: Retreat of topsoil surcharged windrow and loading of dump trucks.

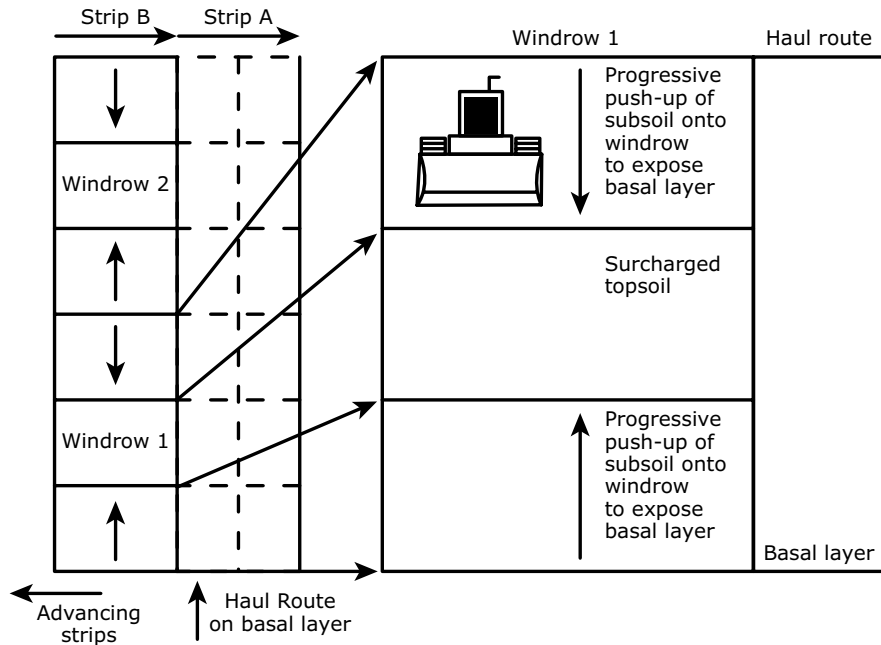

Figure F.3: Surcharging of windrow with topsoil.

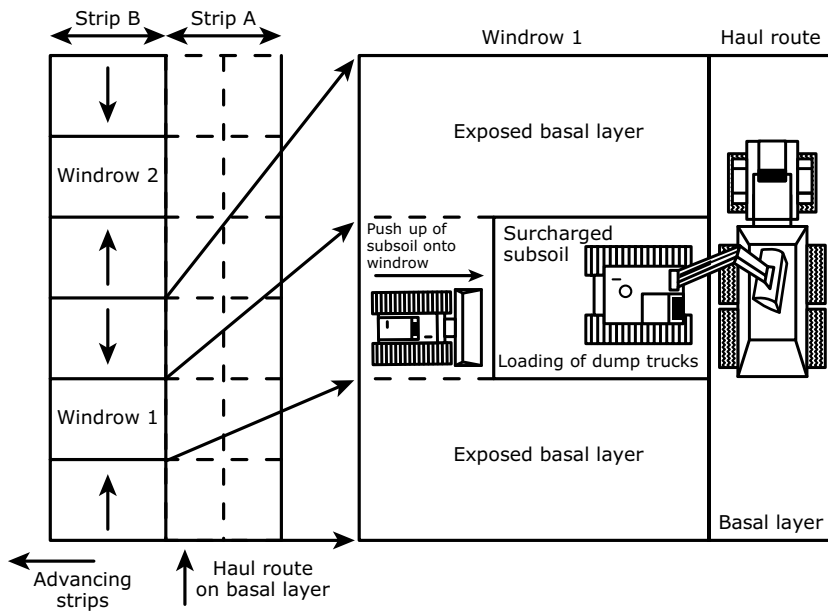

Figure F.4: Retreat of topsoil surcharged windrow and loading of dump trucks.

GOOD PRACTICE GUIDE FOR HANDLING SOILS

In Mineral Workings

PART TWO: Model Methodology

- Sheet G -

Building Soil Storage Mounds
with Bulldozers and Dump Trucks

Author: Dr R N Humphries CBIol CSci FRSB FBSSS FIQ
- Blakemere Consultants Ltd & Celtic Energy Ltd

Supporting artwork was provided by R Shelton (H J Banks & Co)
and D Fisher (Blue Room Graphics Ltd).

Preface

The purpose of Sheet G of the guidance is to provide a model method of best practice where bulldozers and dump trucks are used to build soil storage mounds.

The guidance is intended for use by planning officials, statutory consultees, mineral operators and their supporting teams and specialist consultants, and earth-moving contractors, their site supervisors and machine operators.

Successful soil handling schemes are dependent on the soil resources being clearly identified and the conditions in which they are to be handled. This information should be contained in the Soil Resource & Management Plan (SRMP) and communicated to those involved in its implementation.

Key issues to be addressed are:

- i) Avoiding conditions when soils are wet/ plastic during handling
- ii) The minimisation of soil compaction caused by trafficking and soil wetness
- iii) Using appropriate remedial treatments where these are necessary
- iv) Minimising soil loss, and mixing of soil layers or different soil types.

The SRMP should specify the type of earth-moving machinery and soil handling practice, and the soil wetness condition (see Part One of the Guidance) to be deployed to achieve the planned after use, soil functioning, and the environmental and ecosystem services. It is to be communicated in full to all involved and in particular to the supervisors and machine operators by appropriate means; including tool-box talks and site demonstrations. Supervision by trained supervisory staff is essential, as are monitoring and reporting.

The guidance does not specify the size or model of equipment as this is left to the mineral operator and contractor to specify and provide. The machines must be of a kind which are appropriate for the task and the outcomes required, and to be able to carry out the work safely and efficiently.

Should the agreed methodology need to be modified or changed significantly, this should be agreed in advance with the mineral planning authority. The SRMP should include a mechanism whereby unexpected less significant changes can be quickly resolved through consultation between the operator, the planning authority and statutory consultee, and soil specialist.

All persons involved in the handling of soils must comply with all relevant legislation with respect to Health and Safety, in particular the Health and Safety at work Act 1974 and in the case of mineral extraction operations, The Quarries Regulations 1999 and its relevant statutory provisions; in particular, those aspects which relate to the construction and removal of tips, mounds and similar structures. These requirements take preference over any suggested practice in this Sheet and the SRMP should have taken these into account.

The users of this guidance are solely responsible for ensuring it complies with all safety legislation and good practice, including the manufacturer's specifications for the safe operation of the specific machines being used, and that all machines are in a good condition and well maintained and are suitable for the task. It is important that those involved in the operation of earth moving machines are competent and have the necessary training and certification.

Introduction

This soil handling method uses low ground pressure bulldozers to build the storage mound in combination with dump trucks to transport the soil. Top- and subsoil(s) are to be stored in separate mounds or in clearly defined parts of mounds, in some circumstances where the topsoil can be easily recovered it may be laid over the subsoil.

The space available for storage in mineral workings is often limited and this determines the 'height' of mounds. For topsoil, the preference is for 1 to 3m height in order to minimize the impact of storage on biological processes, whereas for subsoils where the biological activity is lower, subject to safe operations, mounds are often raised to heights of 3 to 5m depending on the resilience of the soils to compaction (see **Part One & Supplementary Note 3**).

In this soil handling option, the mounds are either built as one 'tier' or 'multi-tier' high. In the single tier only the bulldozer traffic the soil surface and usually the final surface. In the multi-tier, the mound is also trafficked by loaded dump trucks.

Advantages & Disadvantages

Storage vs Direct Placement:

The advantages of storage are:

- i) It gives flexibility in the operation of the mineral site
- ii) Flexibility (i.e., weather and ground conditions) when it is reused.

The disadvantages are:

- i) There is a high risk of compaction of the soil material by stacking in the mound which later cannot be effectively treated
- ii) There may be significant degradation of biological functions with long-term storage.

Single vs Multi-tier Mounds:

The advantage of multi-tier mounds is that they take less space. The disadvantages are:

- i) With multi-tier mounds there is high risk of severe compaction of the soil material layers by repeated trafficking by laden dump trucks

in the building of multi-tier mounds which later cannot be effectively treated

- ii) There may be a longer delay in recovery of the soil's biological functions on replacement.

Suitability

Soil storage is less suitable where:

- i) The subsoil(s) are significantly less resilient to compaction (such as silts and sandy clay loams) and when decompaction treatments cannot be relied upon to be effective because of a risk of soil wetness operational limitations (such as the unavailability of effective decompaction tools) (see **Part One and Supplementary Notes 3 & 4**)
- ii) The intended after use, and environmental and ecosystem services are dependent on maintaining functional characteristics such as soil porosity and hence drainage and aeration, plant available water capacity, and low resistance to plant root growth. This usually includes the most productive agricultural, horticultural and forestry land, many types of natural habitats, and where water storage/infiltration is of importance for the risk of flooding
- iii) The bed/strip practice using excavators is used (**Sheet A**) as the compaction caused can negate its benefit
- iv) Multi-tier mounds are used, particularly where the intended after use, and the environment and ecosystem services are dependent on maintaining functional characteristics such as soil porosity and hence drainage and aeration, plant available water capacity, and low resistance to plant root growth. This usually includes the most productive agricultural and forestry land, many types of natural habitats, and where water storage/infiltration is not of importance for the risk of flooding.

MODEL METHODOLOGY

G.1 Key operational points to minimize the risk of severe soil compaction and soil wetness are summarised in Boxes G.1 and G.2.

Box G.1 - To minimize compaction:

- Strip in advance the soil to basal layer along haul routes and the operational footprint of the storage mound
- The soils are to be pushed by the bulldozer to form the mound in as thick layers as possible whilst maintaining their efficient operation
- The machines are to only work when ground or soil surface conditions enable their efficient operation
- The dump trucks should only operate on the 'basal'/non-soil layer, and their wheels must not in any circumstances run on to the tipped soil
- In the raising of multi-tier mounds, trafficking is to be confined to the upper surface of the lower tier. This layer will require decompaction on excavation of the mound.

Box G.2 - To minimise the wetting of soils:

- Site soil mounds in dry locations and protect from run-off from adjacent areas. Drain if a wet location
- Raise the soil mound to maximum height progressively along the axis of the mound and shape the mound as it is being built to shed water and whenever stripping is suspended
- Measures are required to protect the face of the soil layer from ponding of water and maintain the basal layer in a condition capable of supporting dump trucks.

G.2 The timing of the building of the soil storage mounds will be governed by the weather and soil conditions governing stripping (see **Sheets A, E, F, I**). The mounds should be sited on dry ground and not in hollows and should not disrupt local surface drainage (Box G.3). Where necessary mounds should be protected from run-off/ponding by a cut-off ditch which is linked to appropriate water discharge facilities. Where the storage mound is in a hollow due to the removal of surface soils, measures should be undertaken to ensure that water is not able to pond within the storage area.

G.3 All machines must be in a safe and efficient working condition at all times. The machines are to

Box G.3

Where soils such as peat need to be kept in a wet condition this may require storage in bunded cells where receiving rainfall cannot drain. Here, the use of bulldozers is not appropriate for handling peat, and excavators and dump trucks are to be used (**Sheets A – D**).

only work when ground conditions enable safe and efficient operation. Otherwise the operation is to be suspended until suitable remedial measures can be put in place.

G.4 The operation should follow the detailed stripping/storage plan set out in the SRMP showing soil units to be stripped, haul routes and the phasing of vehicle movements. Different soil units to be kept separate are to be marked out and information to distinguish types and layers, and ranges of thickness needs to be conveyed to the operational supervisor/operator. The haul routes and soil storage areas must be defined and should be stripped first in a similar manner. Detailed daily records should be kept of operations undertaken, and site and soil conditions.

G.5 Adopting the practices outlined in **Sheets A, F** or **I**, where relevant, remove topsoil and subsoil to basal layer from the haul routes, footprint of the storage mound and any other operating area in advance. The soils should be stored in their respective mounds.

G.6 The dump trucks must only travel within the haul route and operational areas. The trucks should enter the storage area, reverse and tip the soil load starting at the furthest point of the mound from the point of access.

G.7 The low ground pressure bulldozer pushes the soil into a mound of the required dimensions (**Figure G.1**). The bulldozer is used to shape the sides as the mound is progressively formed to promote the shedding of rain, particularly at the end of each day, but also on the onset of rain during the day. This should include any exposed incomplete surfaces.

G.8 The process is repeated with the tipping of soil against the forming mound, and without the dump truck wheels traversing onto previously tipped material. The operation continues progressively along the main axis of the mound. Without the trucks rising onto the soil mound, the typical height of a mound raised by bulldozer is in the order of 4-6m.

G.9 Work should stop in wet conditions (Box G.4) with measures undertaken to shed water from the soil surfaces and to prevent ponding at the base of the mound and on the basal layer. At the start of each day ensure there is no ponding on the basal layers and operating areas.

Box G.4 - Rainfall Criteria:

- In light drizzle soil handling may continue for up to four hours unless the soils are already at/near to their moisture limit
- In light rain soil handling must cease after 15 minutes
- In heavy rain and intense showers, handling shall cease immediately

In all of the above, after rain has ceased, soil tests shall be applied to determine whether handling may re-start, provided that the ground is free from ponding and ground conditions are safe to do so.

G.10 To raise the mound higher, the trucks will have to travel on the upper surface of the mounded soils, or long reach excavators used to cast-up the soil. In this case the mound should be raised to its maximum height (**Figure G.2**). A ramp will have to be provided for the trucks to rise onto the surface of the first tier, which should be capable of trafficking without difficulty. The next tier would be formed repeating the process described above. If further tiers are required, the process would be repeated again.

G.11 Any exposed edges/surfaces should be shaped using the bulldozer blade on the onset of rain during the day. All surfaces should be shaped to shed water at the end of the day. The final outer surface should be progressively shaped using the

bulldozer blade to promote the shedding of rain.

G.12 Work should stop in wet conditions (Box G.4) with measures undertaken to prevent ponding at the base of the mound and on the basal layer. At the start of each day ensure there is no ponding on the basal layers and operating areas.

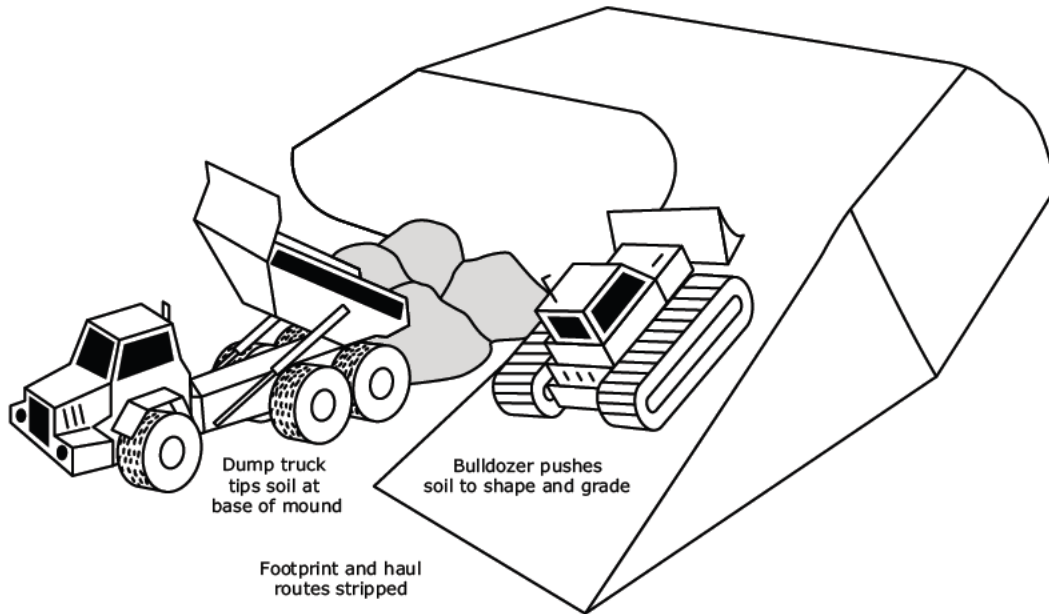

Figure G.1: Soil storage mound construction with bulldozer and dump trucks: Single tier mound.

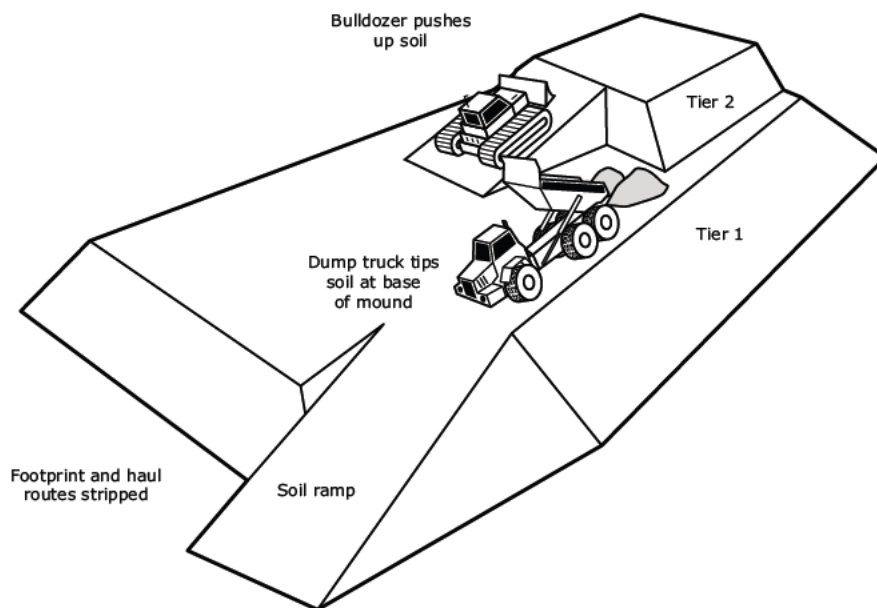

Figure G.2: Soil storage mound construction with bulldozers and dump trucks: Multi-tier mound..

GOOD PRACTICE GUIDE FOR HANDLING SOILS

In Mineral Workings

PART TWO: Model Methodology

- Sheet H-

Soil Replacement with Bulldozers and Dump Trucks
- Windrow Practice

Author: Dr R N Humphries CBiol CSci FRSB FBSSS FIQ
- Blakemere Consultants Ltd & Celtic Energy Ltd

Supporting artwork was provided by R Shelton (H J Banks & Co)
and D Fisher (Blue Room Graphics Ltd).

Preface

The purpose of Sheet H of the guidance is to provide a model method of best practice where bulldozers and dump trucks are to be used to replace soil using the windrow practice.

The guidance is intended for use by planning officials, statutory consultees, mineral operators and their supporting teams and specialist consultants, and earth-moving contractors, their site supervisors and machine operators.

Successful soil handling schemes are dependent on the soil resources being clearly identified and the conditions in which they are to be handled. This information should be contained in the Soil Resource & Management Plan (SRMP) and communicated to those involved in its implementation.

Key issues to be addressed are:

- i) Avoiding conditions when soils are wet/plastic during handling
- ii) The minimisation of soil compaction caused by trafficking and soil wetness
- iii) Using appropriate remedial treatments where these are necessary
- iv) Minimising soil loss, and mixing of soil layers or different soil types.

The SRMP should specify the type of earth-moving machinery and soil handling practice, and the soil wetness condition (see Part One of the Guidance) to be deployed to achieve the planned after use, soil functioning, and the environmental and ecosystem services. It is to be communicated in full to all involved and in particular to the supervisors and machine operators by appropriate means; including tool-box talks and site demonstrations. Supervision by trained supervisory staff is essential, as are monitoring and reporting.

The guidance does not specify the size or model of equipment as this is left to the mineral operator and contractor to specify and provide. The machines must be of a kind which are appropriate for the task and the outcomes required, and to be able to carry out the work safely and efficiently.

Should the agreed methodology need to be modified or changed significantly, this should be agreed in advance with the mineral planning authority. The SRMP should include a mechanism whereby unexpected less significant changes can be quickly resolved through consultation between the operator, the planning authority and statutory consultee, and soil specialist.

All persons involved in the handling of soils must comply with all relevant legislation with respect to Health and Safety, in particular the Health and Safety at work Act 1974 and in the case of mineral extraction operations, The Quarries Regulations 1999 and its relevant statutory provisions; in particular those aspects which relate to the construction and removal of tips, mounds and similar structures. These requirements take preference over any suggested practice in this Sheet and the SRMP should have taken these into account.

The users of this guidance are solely responsible for ensuring it complies with all safety legislation and good practice, including the manufacturer's specifications for the safe operation of the specific machines being used, and that all machines are in a good condition and well maintained and are suitable for the task. It is important that those involved in the operation of earth moving machines are competent and have the necessary training and certification.

Introduction

In this handling option, bulldozers are used to spread the replaced soil from series of linear surcharged strips (windrows). The windrow replacement practice is sometimes referred to as the ‘peninsular’ method.

It involves the sequential replacement of the individual layers of soil identified in the Soil Resource & Management Plan (SRMP). The method can be used for both top and subsoil.

The area to be replaced is divided into windrows from which excess soil is pushed out (from each side) over the adjacent unsoiled parts. The efficient operational distance of the bulldozers push and the safe height for the dump trucks to reverse and tip the soils defines the height of the surcharged windrow and the distance between the windrows. The following guidance can also be adopted where only a single soil horizon is to be replaced.

There is a hybrid excavator and bulldozer practice (see **Sheet K**) often referred to as a ‘loose-tipping’ method without the use of windrows where the subsoil(s) is replaced by the excavator method (**Sheet D**) with the topsoil then spread by bulldozer.

Advantages & Disadvantages

The advantages of this machinery combination and handling practice are:

- i) It is a relatively simple operation to undertake and can be quicker than the excavator combination with the bed/strip practice
- ii) If the practice is applied sequentially across the site, the windrow replacement practice can offer flexibility in respect of short dry periods and likely wet weather, operationally, it can be less prone to delays and stoppages in uncertain weather patterns.

The disadvantages are several:

- i) There is risk of compaction of the replaced soil layers by repeated trafficking by the bulldozer and the loaded dump trucks as they enter and tip the soils on the windrows. Hence, remedial treatments are likely to be relied upon
- ii) It can cause patterned ground due to

uneven soil depths and where some areas are more compacted than others

- iii) It is more difficult to create localised changes in soil types and variation in horizon depth over short distances.

Suitability

Whilst the method is not considered ‘best practice’, it may be acceptable in circumstances where:

- i) The subsoil(s) have a high resilience to further compaction (see **Part One**) and when decompaction treatments can be more relied upon to be effective because of a low risk of soil wetness (low rainfall areas/prolonged dry conditions) or operational limitations (such as the availability of effective decompaction tools)
- ii) The intended after use, and environmental and ecosystem services are less dependent on maintaining functional characteristics such as soil porosity and hence drainage and aeration, plant available water capacity, and low resistance to plant root growth. This may include low productivity agricultural and forestry land, some types of natural habitats, and where water storage/infiltration is of lesser importance for the risk of flooding. Where the soils are stored prior to replacement, effective remedial treatment may have to be relied upon
- iii) It is suited to the placement of a single layer of topsoil rather than a series of soil layers
- iv) The soils have been placed into storage stockpiles.

MODEL METHODOLOGY

Basic Soil Replacement Operation

H.1 The following is the basic model methodology using bulldozers with dump trucks and the windrow practice. It is presented here, firstly without any remedial interventions to give clarity of the methodology. The methodology is then repeated with interventions to demonstrate how integration is to be achieved.

H.2 Key operational points to minimise the risk of severe soil compaction and soil wetness are summarised in Boxes H.1 and H.2.

Box H.1 - To minimize compaction:

- The dump trucks should only operate on the 'basal'/non-soil layer when not entering the windrows
- The machines are to only work when ground conditions enable their efficient operation
- The soils are to be spread by the bulldozer in as thick layer as possible whilst maintaining their efficient operation
- The bulldozer should make the minimal number of passes over the soil as possible
- The soil layers are to be in 'dry' condition

Box H.2 - To minimize the wetness of the soil and re-wetting of the soil:

- The windrow system provides a basis to regulate the exposure of lower soil layers to periods of rain and a means of maintaining soil moisture contents. The soil profile within the active strip should be replaced to the topsoil surface layer before rainfall occurs and before replacement is suspended
- Measures are required to protect the face of the soil layer from ponding of water and maintain the basal layer in a condition capable of supporting dump trucks
- The area to be restored is to be protected from in-flow of water, ponding etc. Wet sites must be drained in advance. Before the operation starts the basal layer should be to level and clean.

H.3 The timing of soil handling operations should only take place when the soils are in a 'dry and friable' condition (ie when it breaks and shatters when disturbed rather than smears and deforms) (see **Part One, Supplementary Note 4**). Prior to the start or recommencement of soil handling they should be tested to confirm they are in suitably dry condition (see Box H.3).

H.4 Soil handling (by any machinery combination and handling practice) is not to take place during rain, sleet or snow and in these conditions should be prohibited due to unsafe machine operating conditions. Prior to commencing operations a medium/long term weather forecast should be

Box H.3 - Test for Dry and Friable Soils

Soil tests are to be undertaken in the field. Samples shall be taken from at least five locations on the soil handling area and at each soil horizon to the full depth of the profile to be recovered/replaced. The tests shall include visual examination of the soil and physical assessment of soil consistency.

i) Examination

- If the soil is wet, films of water are visible on the surface of soil particles or aggregates (e.g. clods or peds) and/or when a clod or ped is squeezed in the hand it readily deforms into a cohesive 'ball' means **no soil handling to take place**
- If the sample is moist (i.e. there is a slight dampness when squeezed in the hand) but it does not significantly change colour (darken) on further wetting, and clods break up/crumble readily when squeezed in the hand rather than forming into a ball means **soil handling can take place**
- If the sample is dry, it looks dry and changes colour (darkens) if water is added, and it is brittle means **soil handling can take place**

ii) Consistency**First Test**

Attempt to mould soil sample into a ball by hand:

- Impossible because soil is too dry and hard or too loose and dry means soil handling can take place
- Impossible because the soil is too loose and wet means no soil handling to take place
- Possible - GO TO SECOND TEST

Second Test

Attempt to roll ball into a 3mm diameter thread by hand:

- Impossible because soil crumbles or collapses means **soil handling can take place**
- Possible means **no soil handling to take place**

NB: It is impossible to roll most coarse loamy and sandy soils into a thread even when they are wet. For these soils, the Examination Test alone is to be used.

obtained which gives reasonable confidence of soil handling being completed without significant interruptions from rainfall events. The soil based criteria set out in Box H.4 are to be used to determine whether soil handling should cease or be interrupted with the occurrence of rain.

Box H.4 - Rainfall Criteria:

- In light drizzle soil handling may continue for up to four hours unless the soils are already at/near to their moisture limit
- In light rain soil handling must cease after 15 minutes
- In heavy rain and intense showers, handling shall cease immediately

In all of the above, after rain has ceased, soil tests shall be applied to determine whether handling may re-start, provided that the ground is free from ponding and ground conditions are safe to do so.

H.5 All machines must be in a safe and efficient working condition at all times. The machines are to only work when ground conditions enable safe and efficient operation. Otherwise the operation is to be suspended until suitable remedial measures can be put in place.

Box H.5

Whilst there can be a lower of a risk of compaction when using wide tracked ('low ground pressure' (LGP)) bulldozers, in some circumstances they may require to traffic the soil surface more than standard machines to achieve the same work rate, and therefore the advantage of their use may be less than anticipated. However, the risk of severe compaction and reliance on remedial treatments may be less with the use of LGP machines.

H.6 The operation should follow the detailed soil plan set out in the SRMP showing soil units to be replaced, haul routes and the phasing of vehicle movements. Different soil units to be kept separate are to be marked out and information to distinguish types and layers, and ranges of thickness needs to

be conveyed to the operational supervisor/operator. The haul routes and soil storage areas must be defined and should be replaced in a similar manner. Detailed daily records should be kept of operations undertaken, and site and soil conditions.

Box H.6

As a general rule, a moving loaded dump truck can exert sufficient pressure to cause compaction of loose soil to a depth of 40 – 60cm depending on its wetness.

H.7 Either the process progresses across the site until there is a complete subsoil cover before topsoil is replaced or it is done in sections with the full profile being completed before another is started. The latter sequential approach has the advantage that a large expanse of subsoil is not exposed to wetting prior to top-soiling.

H.8 Profile boards should be used to control soil horizon thickness being replaced and overall levels achieved verified using soil pits.

Box H.7 - Integration of Decompaction & Stone/Debris Removal

Option 1: is where the basal layer needs to be treated but is left until the subsoil is placed when both are decompacted together, followed by the decompaction of the topsoil and subsoil layers together (and basal layer) using tines that are long enough. This option is not suited to digging where the soil horizons would be mixed.

Option 2: is where each layer is treated separately by either tines or digging.

Option 3 is where the basal layer is treated or left untreated, followed by the placement of the subsoil and topsoil layers, which are to be decompacted by the use of tines. In the case of deep horizons this option can be limited by the capability of the machinery, the tines or bucket used. This option is not suited to digging where the soil horizons would be mixed.

H.9 The bulldozer is to work and travel on the soil layers (Box H.5). The dump trucks should avoid reversing onto the windrows until they have been surcharged sufficiently to buffer any underlying functional soil layer from compaction.

H.10 The area to be soiled is divided into a series of windrows on which the first loads of subsoil are pushed out by bulldozer to form the windrow of subsoil of 400 – 600mm thick (Box H.6). It is then surcharged with further subsoil being tipped by dump trucks reversing over the initial layer (**Figures H.1 – H.2**). The excess soil on the surcharged windrows is pushed out laterally by the bulldozer to cover the area between the windrows to the required depth.

H.11 On completion of the subsoil placement, the topsoil is replaced by the above procedure (**Figure H.3 & H.4**). The dump trucks should avoid reversing onto the windrows until they have been surcharged to buffer any underlying functional subsoil/basal layer from compaction (see Box H.6).

H.12 At the end of each day the current sector with soils being replaced must be completed if rain is forecast. If during a day it is evident that a full windrow cannot be completed, then that part must be completed to topsoil level.

H.13 At the end of each day, or during the day if interrupted by rain, make provisions to protect base of restored strip from ponding/runoff by sumps and grips, and also clean and level the basal layer. At the start of each day ensure there is no ponding in the current strip or operating areas, and the basal layer is to level with no ruts.

Methodology with Remedial Actions

H.14 The following is the model methodology, using bulldozers with dump trucks for the windrow practice, with the remedial interventions to demonstrate how integration is to be achieved. The key operational points to minimise the risk of severe soil compaction and soil wetness are summarised in the above Boxes H.1 and H.2.

H.15 Usually there will be a need for decompaction treatment during the replacement operation with this

methodology. Where compaction occurs, treatment will need integrating into the replacement process as will any need for the removal of stones or non-soil debris within the replacement process. Both decompaction and removal of materials procedures are covered in separate **Sheets L to O**.

H.16 The placement of the stripped soils in storage is likely to have contributed to the compaction. Box H.7 sets out some of the remedial options/ combinations to facilitate decompaction, and where necessary, the removal of stones and non-soil debris for a final profile comprising a basal layer, subsoil and topsoil layers. Except for Option 3, these actions need to be undertaken sequentially as each soil strip is placed.

H.17 Prior to commencing operations a weather forecast should be obtained which gives reasonable confidence of soil replacement proceeding without interruptions from rainfall events (Box H.4).

H.18 If significant rainfall occurs during operations, the replacement must be suspended, and where the soil profile has been started it should be replaced to the topsoil level. Replacement must not restart unless the weather forecast is expected to be dry for at least a full day and the soils are in a dry condition (see above Box H.3).

H.19 All machines must be in a safe and efficient working condition at all times. The machines are only to work when ground conditions enable their efficient operation. The work should only be carried out when the basal layer supports the machinery without ruts or is capable of repair/maintenance. Otherwise the operation is to be suspended until suitable remedial measures can be put in place.

H.20 The operation should follow the detailed replacement plan in the SRMP showing the soil units to be replaced, haul routes and the phasing of vehicle movements. The soil units should be defined on the site with information to distinguish types and layers, and thickness and conveyed to the operational supervisor/operator. Different soil units to be kept separate are to be marked out and information to distinguish types and layers, and ranges of thickness needs to be conveyed to

the operational supervisor/operator. Detailed daily records should be kept of operations undertaken and site and soil conditions (including the removal of stones and other non-soil debris that needs to be removed), and the results of the effectiveness of the work undertaken, and any need for additional remedial treatments.

H.21 Profile boards should be used to control soil horizon thickness being replaced and overall levels achieved verified using soil pits. Allowances (ie. bulking factor) should be made for any 'heave' that may take place when the replaced soil is decompacted.

H.22 Only the bulldozer is to work and travel on the soil layers. The dump trucks should avoid reversing onto the windrows until they have been surcharged sufficiently to buffer any underlying functional soil layer from compaction (see above BOX H.6).

H.23 The area to be soiled is divided into a series of windrows. Where there is a requirement to treat compaction and/or remove stones/non-soil debris in the basal layer, these need to be carried out in the area to be soiled (including the windrows being formed).

H.24 Where there is a requirement to treat compaction and/or remove stones and non-soil debris in the basal layer, these need to be carried out in the area to receive the subsoil. Decompaction can be by digging with the excavator bucket or by bulldozer drawn tines (**Sheets N & O**). Stone removal may require prior ripping/digging to release them from the soil, followed by the excavator using a stone-rake bucket (to be loaded on a dump truck and removed) (**Sheets L & M**). Where these treatments are deployed, to minimise additional compaction/recompaction, only the bulldozer need to work and traffic the basal layer and the soil surfaces, and the excavator and the dump truck being loaded with the recovered stones/debris stand and travel on the untreated basal layer.

H.25 On completion of the remedial work, the subsoil windrow is formed as described above with the bulldozer pushing out the excess sub-soil to cover the area to the required depth (**Figures H.1**

& H.2). The dump trucks should avoid reversing onto the windrows, particularly until they have been surcharged to buffer any underlying functional basal layer from compaction.

H.26 On completion of the subsoil placement, where there is a requirement to treat compaction and/or remove stones/non-soil debris in the subsoil layer, these need to be carried out prior to the topsoil being laid.

H.27 Where there is a requirement to treat compaction and/or remove stones and non-soil debris in the subsoil, these need to be carried out prior to the topsoil layer of soil being laid. Decompaction can be by digging with the excavator bucket or by bulldozer drawn tines (**Sheets N & O**). Stone removal may require prior ripping/digging to release them from the subsoil, followed by the excavator using a stone-rake bucket (to be loaded on a dump truck and removed) (**Sheets L & M**). Where these treatments are deployed, to minimise additional compaction/recompaction, only the bulldozer need to work and traffic the subsoil layer, and the excavator and the dump truck being loaded with the recovered stones/debris stand and travel on the untreated basal layer.

H.28 The topsoil is replaced by the same windrow procedure as described above (see above H.10 & H.11) with the bulldozer pushing out the excess topsoil to cover the area to the required depth (**Figures H.3 & H.4**). The dump trucks should avoid reversing onto the windrows, particularly until they have been surcharged to buffer any underlying functional sub-soil layer from compaction (Box H.6).

H.29 Where there is a requirement to treat compaction and/or remove stones and non-soil debris in the topsoil, decompaction can be by digging with the excavator bucket or by bulldozer drawn tines (**Sheets N & O**). Stone removal may require prior ripping/digging to release them from the topsoil, followed by the excavator using a stone-rake bucket (to be loaded on a dump truck and removed) (**Sheets L & M**). Where these treatments are deployed, to minimise additional compaction/recompaction, only the bulldozer need to work and traffic the topsoil, and the excavator and the dump

truck being loaded with the recovered stones/debris stand and travel on the untreated basal layer.

H.30 In some circumstances decompaction can be undertaken from the top-soil surface once the placing of the soils is complete (Box H.7, Option 3). Here, stone and non-soil debris removal would be restricted to the topsoil layer.

However, this Option is only advisable where it is certain that it will be effective and will not compromise the achievement of the intended after use, soil functions, and environmental and ecosystem services.

H.31 At the end of each day the current soil placement must be completed if rain is forecast. If during a day it is evident that a full strip cannot be completed, then only start part of a strip; this too must be completed.

H.32 At the end of each day, or during the day if interrupted by rain, make provisions to protect base of restored strip from ponding/runoff by sumps and grips, and also clean and level the basal layer. At the start of each day ensure there is no ponding in the current strip or operating areas, and the basal layer is to level with no ruts.

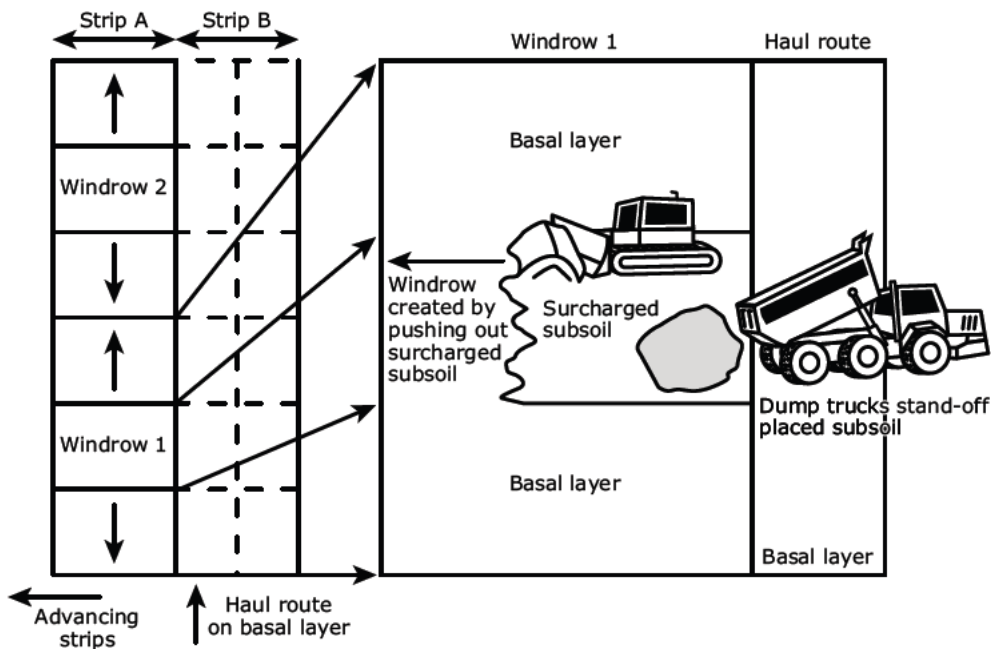

Figure H.1: Advance of subsoil surcharged windrow from dump trucks.

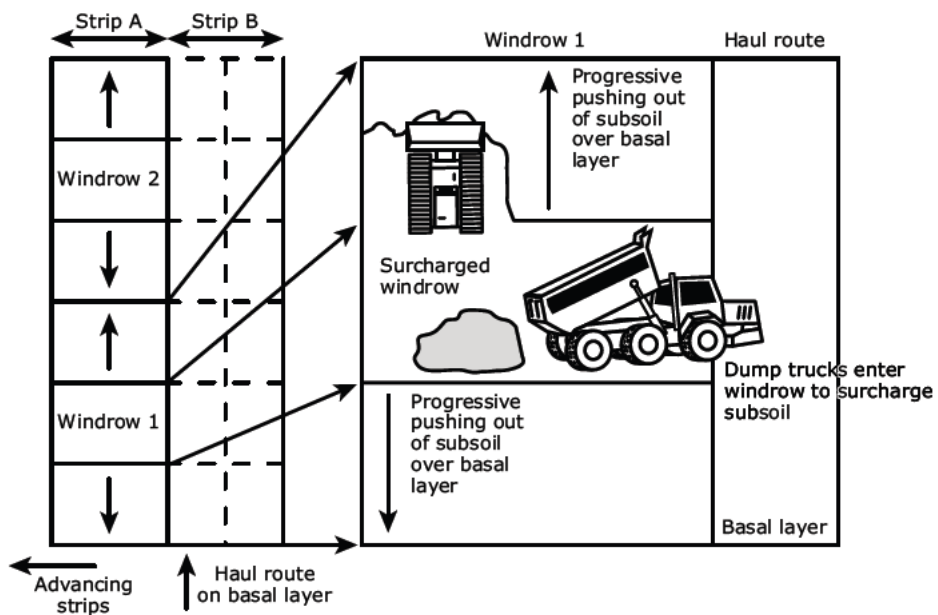

Figure H.2: Spreading of subsoil from surcharged windrow.

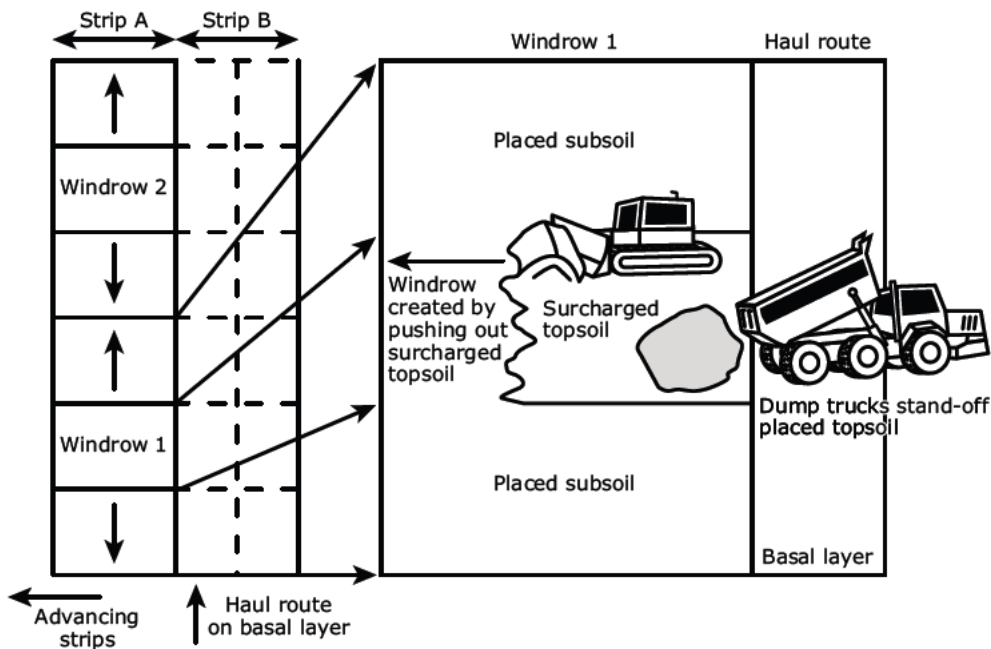

Figure H.3: Advance of topsoil surcharged windrow from dump trucks.

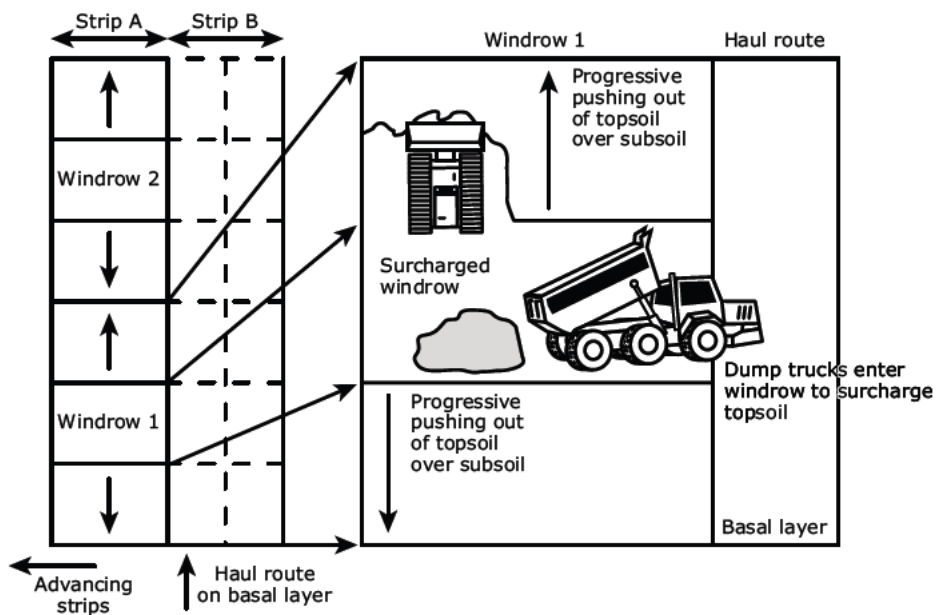

Figure H.4: Spreading of topsoil from surcharged windrow.

GOOD PRACTICE GUIDE FOR HANDLING SOILS

In Mineral Workings

PART TWO: Model Methodology

- Sheet I -

Soil Stripping with Bulldozers and Dump Trucks
- Modified Layer by Layer Practice

Author: Dr R N Humphries CBiol CSci FRSB FBSS FIQ
- Blakemere Consultants Ltd & Celtic Energy Ltd

Supporting artwork was provided by R Shelton (H J Banks & Co)
and D Fisher (Blue Room Graphics Ltd).

Preface

The purpose of Sheet I of the guidance is to provide a model method of best practice where bulldozers and dump trucks are to be used to strip soil using a modified soil layer by layer practice.

The guidance is intended for use by planning officials, statutory consultees, mineral operators and their supporting teams and specialist consultants, and earth-moving contractors, their site supervisors and machine operators.

Successful soil handling schemes are dependent on the soil resources being clearly identified and the conditions in which they are to be handled. This information should be contained in the Soil Resource & Management Plan (SRMP) and communicated to those involved in its implementation.

Key issues to be addressed are:

- i) Avoiding conditions when soils are wet/plastic during handling
- ii) The minimisation of soil compaction caused by trafficking and soil wetness
- iii) Using appropriate remedial treatments where these are necessary
- iv) Minimising soil loss, and mixing of soil layers or different soil types.

The SRMP should specify the type of earth-moving machinery and soil handling practice, and the soil wetness condition (see Part One of the Guidance) to be deployed to achieve the planned after use, soil functioning, and the environmental and ecosystem services. It is to be communicated in full to all involved and in particular to the supervisors and machine operators by appropriate means; including tool-box talks and site demonstrations. Supervision by trained supervisory staff is essential, as are monitoring and reporting.

The guidance does not specify the size or model of equipment as this is left to the mineral operator and contractor to specify and provide. The machines must be of a kind which are appropriate for the task and the outcomes required, and to be able to carry out the work safely and efficiently.

Should the agreed methodology need to be modified or changed significantly, this should be agreed in advance with the mineral planning authority. The SRMP should include a mechanism whereby unexpected less significant changes can be quickly resolved through consultation between the operator, the planning authority and statutory consultee, and soil specialist.

All persons involved in the handling of soils must comply with all relevant legislation with respect to Health and Safety, in particular the Health and Safety at work Act 1974 and in the case of mineral extraction operations, The Quarries Regulations 1999 and its relevant statutory provisions; in particular those aspects which relate to the construction and removal of tips, mounds and similar structures. These requirements take preference over any suggested practice in this Sheet and the SRMP should have taken these into account.

The users of this guidance are solely responsible for ensuring it complies with all safety legislation and good practice, including the manufacturer's specifications for the safe operation of the specific machines being used, and that all machines are in a good condition and well maintained and are suitable for the task. It is important that those involved in the operation of earth moving machines are competent and have the necessary training and certification.

Introduction

In the past soil layers have been stripped in their entirety one by one. Firstly the topsoil, then the subsoil layers by layer until the basal layer is exposed. The method deployed across the entire area is now discredited because of the likely severe compaction caused by the trafficking of the machines over much of the exposed soil surfaces. However, by restricting the extent of the ongoing process to blocks or wide bands of soil, to enable the dump trucks to travel on the basal layer, there may be instances where this ‘modified’ layer by layer approach can be deployed.

In this practice, only the bulldozer works on the exposed soil layers to form soil bunds along the exposed edge for loading by an excavator (usually) standing on the mound. This approach was described and illustrated in MAFF Sheet 13 <https://webarchive.nationalarchives.gov.uk/20090318025435/http://www.defra.gov.uk/farm/environment/land-use/soilguid/sheet13.pdf>.

It is also similar to the bulldozer practice described in **Sheet F**, but without the formation of windrows and the need for the excavator to traffic the surcharged soil to recover and load it into the dump trucks. In this respect it is easier to operate than the windrow practice and likely to cause less compaction.

The following modified guidance can also be adopted where only a single soil horizon is to be stripped.

Advantages & Disadvantages

The advantages of the modified handling practice are:

- i) It is very simple to administer requiring little supervision and skill
- ii) It can be quicker than both the excavator combination with the bed/strip and windrow practices
- iii) It offers flexibility in respect of short soil drying periods and likely wet weather as it is less susceptible to stoppages due to soil rewetting as a transpiring vegetation cover

can be retained later into the stripping programme. It is particularly suited to northerly and western, and upland locations, and particularly when there are uncertain weather patterns.

The disadvantages of the modified handling practice are:

- i) There is risk of compaction of the top- and subsoil layers by the repeated trafficking of the bulldozer, even if a low ground pressure machine is used, as it pushes soil to the windrows. Hence, subsequent remedial treatments are likely to be relied upon
- ii) It is slow react to localised changes in soil types and variation in horizon depth, and can result in the mixing of soil horizons
- iii) It is not suited to the stripping of thin and ‘patterned’ soil layers, and cleanly exposing the top-sub-soil interface.

Suitability

Neither the unmodified or modified practice are suitable for sites requiring archaeological investigations and reporting, or for ‘watching briefs’ during soil stripping.

The layer by layer handling practice, without modification, is not advisable for the conservation of soil resources and functioning. Whilst the modified method is not considered ‘best practice’, it may be acceptable in circumstances where:

- i) The subsoil(s) have a high resilience to further compaction (see **Part One**) and when decompaction treatments can be more relied upon to be effective because of a low risk of soil wetness (low rainfall areas/prolonged dry conditions) or operational limitations (such as the availability of effective decompaction tools)
- ii) The intended after use, and environmental and ecosystem services are less dependent on maintaining functional characteristics such as soil porosity and hence drainage and aeration, plant available water capacity, and low resistance to plant root growth. This may include low productivity agricultural and forestry land, some types of natural

habitats, and where water storage/infiltration is of lesser importance for the risk of flooding. Where the soils are stored prior to replacement, effective remedial treatment may have to be relied upon

iii) The soils are placed into storage stockpiles.

MODEL METHODOLOGY

I.1 Key operational points to minimise the risk of severe soil compaction and soil wetness with the modified layer by layer practice are summarised in Boxes I.1 and I.2.

Box I.1 - To minimise compaction:

- The dump trucks should normally only operate on the basal layer, and their wheels must not in any circumstances run on to the soil layer(s)
- The adoption of the strip by strip system minimises the need for the trucks to travel on the soil layers
- The machines are to only work when ground conditions enable their efficient operation
- The soils are to be stripped by the bulldozer in as thick layer as possible whilst maintaining their efficient operation
- The bulldozer should make the minimal number of passes over the soil as possible
- The soil layers are to be in 'dry' condition.

Box I.2 - To minimize the wetness of the soil and re-wetting of the soil:

- The modified strip by strip system provides a basis to regulate the exposure of lower soil layers to periods of rain and a means of maintaining soil moisture contents. The soil profile within the active strip should be stripped to the basal layer before rainfall occurs and before stripping is suspended.
- Measures are required to protect the face of the soil layer from ponding of water and maintain the basal layer in a condition capable of supporting dump trucks
- The area to be stripped is to be protected from in-flow of water, ponding etc. Wet sites should be drained in advance

- The maintenance of a transpiring crop is important, and an appropriate cropping regime should be established for the year of soil stripping
- Before stripping, excess vegetation should be removed; in the case of grassland it should be cut or grazed short and arable crops should have been harvested.

I.2 The timing of soil handling operations should only take place when the soils are in a 'dry and friable' condition (ie when it breaks and shatters when disturbed rather than smears and deforms) (see **Part One, Supplementary Note 4**). Prior to the start or recommencement of soil handling, they should be tested to confirm they are in suitably dry condition (see Box I.3).

I.3 Soil handling (by any machinery combination and handling practice) is not to take place during rain, sleet or snow and in these conditions should be prohibited due to unsafe machine operating conditions. Prior to commencing operations a medium/long term weather forecast should be obtained which gives reasonable confidence of soil handling being completed without significant interruptions from rainfall events. The soil based criteria set out in BOX I.4 are to be used to determine whether soil handling should cease or be interrupted with the occurrence of rain. The machines are to only work when ground conditions enable safe and efficient operation. Otherwise the operation is to be suspended until suitable remedial measures can be put in place.

I.5 The operation should follow the detailed stripping plan set out in the SRMP showing soil units to be stripped, haul routes and the phasing of vehicle movements. Different soil units to be kept separate are to be marked out and information to distinguish types and layers, and ranges of thickness needs to be conveyed to the operational supervisor/operator. The haul routes and soil storage areas must be defined and should be stripped first in a similar manner. Detailed daily records should be kept of operations undertaken, and site and soil conditions.

I.6 Demarcate an initial width of the 'strip' of soils to be recovered as the modified layer by layer practice.

Box I.3 - Test for Dry and Friable Soils

Soil tests are to be undertaken in the field. Samples shall be taken from at least five locations on the soil handling area and at each soil horizon to the full depth of the profile to be recovered/replaced. The tests shall include visual examination of the soil and physical assessment of soil consistency.

i) Examination

- If the soil is wet, films of water are visible on the surface of soil particles or aggregates (e.g. clods or peds) and/or when a clod or ped is squeezed in the hand it readily deforms into a cohesive 'ball' means **no soil handling to take place**
- If the sample is moist (i.e. there is a slight dampness when squeezed in the hand) but it does not significantly change colour (darken) on further wetting, and clods break up/crumble readily when squeezed in the hand rather than forming into a ball means **soil handling can take place**
- If the sample is dry, it looks dry and changes colour (darkens) if water is added, and it is brittle means **soil handling can take place**

ii) Consistency**First Test**

Attempt to mould soil sample into a ball by hand:

- Impossible because soil is too dry and hard or too loose and dry means soil handling can take place
- Impossible because the soil is too loose and wet means no soil handling to take place
- Possible - GO TO SECOND TEST

Second Test

Attempt to roll ball into a 3mm diameter thread by hand:

- Impossible because soil crumbles or collapses means **soil handling can take place**
- Possible means **no soil handling to take place**

NB: It is impossible to roll most coarse loamy and sandy soils into a thread even when they are wet. For these soils, the Examination Test alone is to be used.

Box I.4 – Rainfall Criteria:

- In light drizzle soil handling may continue for up to four hours unless the soils are already at/near to their moisture limit
- In light rain soil handling must cease after 15 minutes
- In heavy rain and intense showers, handling shall cease immediately.

In all of the above, after rain has ceased, soil tests shall be applied to determine whether handling may re-start, provided that the ground is free from ponding and ground conditions are safe to do so.

Box I.5

Whilst there can be a lower of a risk of compaction when using wide tracked ('low ground pressure' (LGP)) bulldozers, in some circumstances they may require to traffic the soil surface more than standard machines to achieve the same work rate, and therefore the advantage of their use may be less than anticipated. However, the risk of severe compaction and reliance on remedial treatments may be less with the use of LGP machines.

This is the effective push distance of the bulldozer to bund the soil at the edge of the strip (Box I.5).

I.7 Within each soil unit the soil layers above the base/formation layer are to be stripped layer by layer in the retreating strips/blocks until all the soil is removed (**Figure I.1**).

I.8 The bulldozer is only to stand and work on the soil layer when stripping soils and the excavator on the resulting soil mound, otherwise they are to travel only on the basal/formation layer. The dump trucks are to operate only on the basal layer (**Figure I.2**).

I.9 The topsoil is to be pushed towards the retreating edge and heaped for the excavator to load onto the dump trucks (**Figure I.2**). The topsoil should be recovered to the full width of the segment without mixing with subsoil (not more than 20% of the lower horizon should be exposed at the layer junction within the strip). The thickness and identification of the horizon junction must be verified before and

during stripping. The procedure is repeated until all of the topsoil has been removed.

I.10 The above procedure is then repeated for the sub-soil until all the soil layer has been recovered, and then any subsequent lower layer to be recovered until the basal layer is fully exposed (**Figure I.3**).

I.11 Where the soils are to be directly replaced without storage in mounds, the initial strip of the upper horizons will have to be stored temporarily to release the lowest layer and enable the sequential movement of materials. The stored initial soil material would be placed on the lower layer removed from the final strip at the end of the programme or on partially completed profiles if rain was forecast.

I.12 Where the stripping operation is likely to be interrupted by rain or there is likely to be overnight rain, the soil layer is to be 'sealed' by the bulldozer tracking and 'blading' the exposed surface. Make provisions to protect base of current or next strip from ponding/runoff by sumps and grips, and also clean and level the basal layer. At the start of each day ensure there is no ponding in the current strip or operating areas, and the basal layer is to level with no ruts.

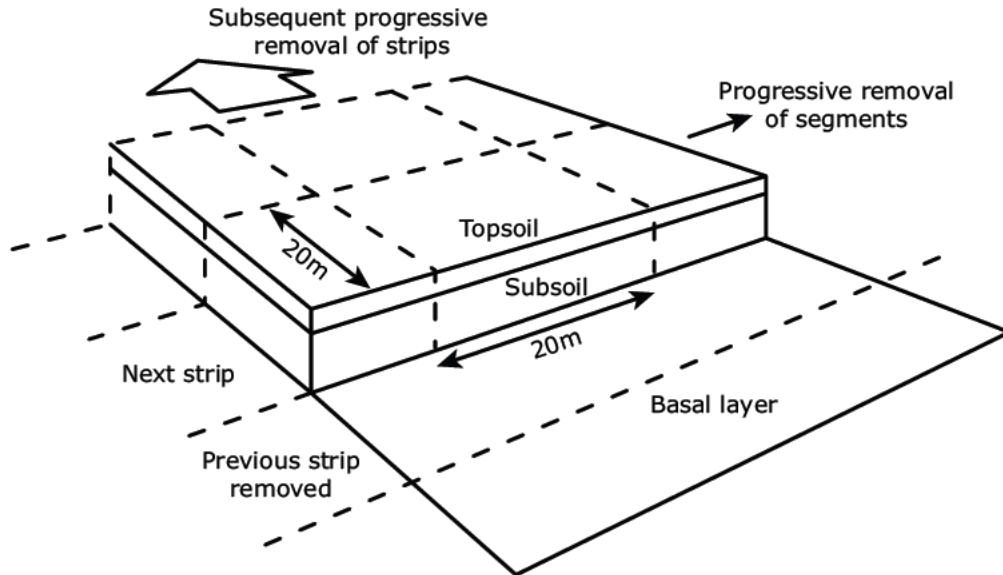

Figure I.1: Soil stripping with bulldozers and dump trucks using modified layer by layer practice.

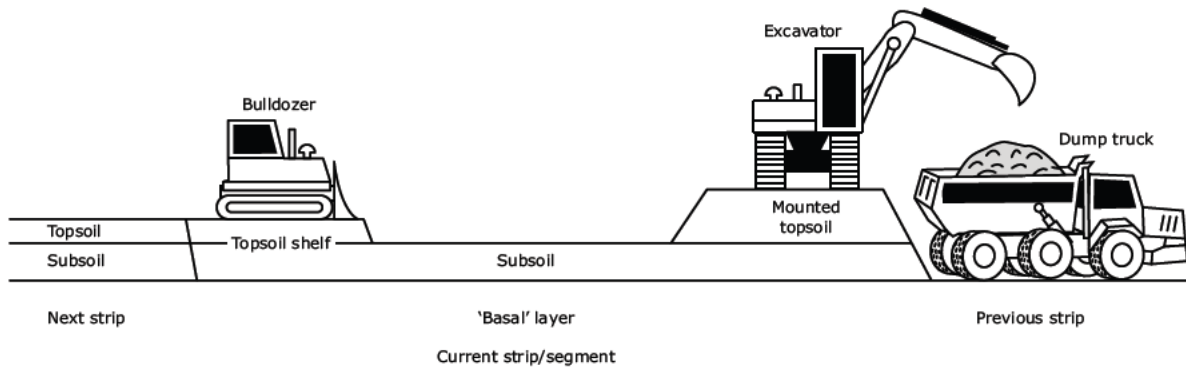

Figure I.2: Soil stripping with bulldozers and dump trucks using modified layer by layer method: Topsoil.

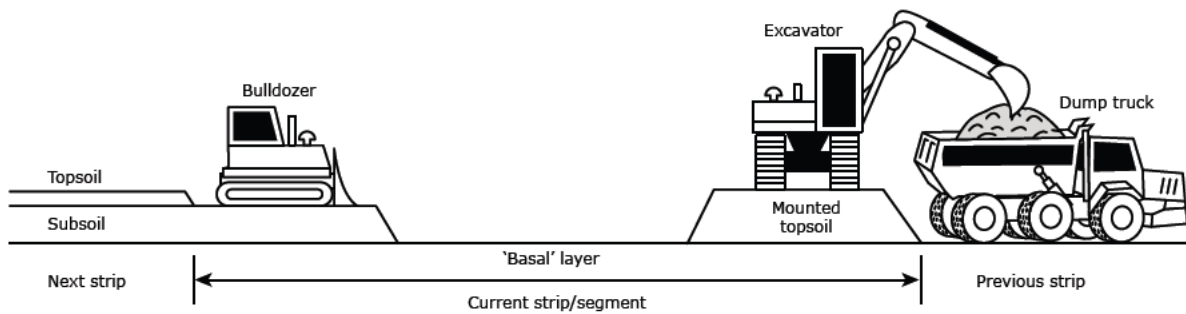

Figure I.3: Soil stripping with bulldozers and dump trucks using modified layer by layer method: Subsoil.

GOOD PRACTICE GUIDE FOR HANDLING SOILS

In Mineral Workings

PART TWO: Model Methodology

- Sheet J -

Soil Replacement with Bulldozers and Dump Trucks
- Modified Layer by Layer Practice

Author: Dr R N Humphries CBiol CSci FRSB FBSS FIQ
- Blakemere Consultants Ltd & Celtic Energy Ltd

Supporting artwork was provided by R Shelton (H J Banks & Co)
and D Fisher (Blue Room Graphics Ltd).

Preface

The purpose of Part Two, Sheet J of the guidance is to provide a model method of best practice where bulldozers and dump trucks are to be used to replace soil using the modified layer by layer practice.

The guidance is intended for use by planning officials, statutory consultees, mineral operators and their supporting teams and specialist consultants, and earth-moving contractors, their site supervisors and machine operators.

Successful soil handling schemes are dependent on the soil resources being clearly identified and the conditions in which they are to be handled. This information should be contained in the Soil Resource & Management Plan (SRMP) and communicated to those involved in its implementation.

Key issues to be addressed are:

- i) Avoiding conditions when soils are wet/plastic during handling
- ii) The minimisation of soil compaction caused by trafficking and soil wetness
- iii) Using appropriate remedial treatments where these are necessary
- iv) Minimising soil loss, and mixing of soil layers or different soil types.

The SRMP should specify the type of earth-moving machinery and soil handling practice, and the soil wetness condition (see Part One of the Guidance) to be deployed to achieve the planned after use, soil functioning, and the environmental and ecosystem services. It is to be communicated in full to all involved and in particular to the supervisors and machine operators by appropriate means; including tool-box talks and site demonstrations. Supervision by trained supervisory staff is essential, as are monitoring and reporting.

The guidance does not specify the size or model of equipment as this is left to the mineral operator and contractor to specify and provide. The machines must be of a kind which are appropriate for the task and the outcomes required, and to be able to carry out the work safely and efficiently.

Should the agreed methodology need to be modified or changed significantly, this should be agreed in advance with the mineral planning authority. The SRMP should include a mechanism whereby unexpected less significant changes can be quickly resolved through consultation between the operator, the planning authority and statutory consultee, and soil specialist.

All persons involved in the handling of soils must comply with all relevant legislation with respect to Health and Safety, in particular the Health and Safety at work Act 1974 and in the case of mineral extraction operations, The Quarries Regulations 1999 and its relevant statutory provisions; in particular those aspects which relate to the construction and removal of tips, mounds and similar structures. These requirements take preference over any suggested practice in this Sheet and the SRMP should have taken these into account.

The users of this guidance are solely responsible for ensuring it complies with all safety legislation and good practice, including the manufacturer's specifications for the safe operation of the specific machines being used, and that all machines are in a good condition and well maintained and are suitable for the task. It is important that those involved in the operation of earth moving machines are competent and have the necessary training and certification.

Introduction

In the past soil layers have been replaced in their entirety one by one. Firstly the subsoil, then the topsoil layer until the basal layer is covered. The method deployed across the entire area is now discredited because of the likely severe compaction caused by the trafficking of the machines over much of the exposed soil surfaces. However, by restricting the extent of the ongoing process to blocks or wide bands of soil, to enable the dump trucks to travel on the basal layer, there may be instances where this ‘modified’ layer by layer approach can be deployed.

In this practice, only the bulldozer works on the exposed soil layers and pushes out the soil from bunds tipped by the dump trucks along the advancing soil edge. This approach was described and illustrated in MAFF Sheet 15 <https://webarchive.nationalarchives.gov.uk/ukgwa/20090318025517/http://www.defra.gov.uk/farm/environment/land-use/soilguid/sheet15.pdf>. It is also similar to the bulldozer practice given in **Sheet H**, but without the formation of windrows and the need for the dump truck to traffic the surcharged soil. In this respect it is easier to operate than the windrow practice and likely to cause less compaction.

The following guidance can be adopted where only a single topsoil horizon is to be placed.

Advantages & Disadvantages

The advantages of the modified handling practice are:

- i) It is very simple to administer requiring little supervision and skill
- ii) It can be quicker than both the excavator combination with the bed/strip and windrow practices
- iii) It offers flexibility in respect of short dry periods and likely wet weather as it is less susceptible to stoppages due to soil rewetting and a vegetation cover can be sequentially established.

The disadvantages of the modified handling practice are:

- i) There is risk of compaction of the top- and subsoil layers by the repeated trafficking of the bulldozer, even if a low ground pressure machine is used, as it pushes out the soil. Hence, subsequent remedial treatments are likely to be relied upon
- ii) It is not suited to the laying of thin and ‘patterned’ soil layers.

Suitability

The layer by layer handling practice, without modification, is not advisable for the conservation of soil resources and functioning. Whilst the modified method is not considered ‘best practice’, it may be acceptable in circumstances where:

- i) The subsoil(s) have a high resilience to further compaction (see **Table 7, Part One**) and when decompaction treatments can be more relied upon to be effective because of a low risk of soil wetness (low rainfall areas/ prolonged dry conditions) or operational limitations (such as the availability of effective decompaction tools)
- ii) The intended after use, and environmental and ecosystem services are less dependent on maintaining functional characteristics such as soil porosity and hence drainage and aeration, plant available water capacity, and low resistance to plant root growth. This may include low productivity agricultural and forestry land, some types of natural habitats, and where water storage/infiltration is of lesser importance for the risk of flooding. Where the soils are stored prior to replacement, effective remedial treatment may have to be relied upon
- iii) The soils have been placed into storage stockpiles
- iv) It is suited to northern and western, and upland locations, and particularly when there are uncertain weather patterns.

MODEL METHODOLOGY

Basic Replacement Operation

The following is the basic model methodology using bulldozers with dump trucks and the modified layer by layer practice. It is presented here, firstly without any remedial interventions to give clarity of the methodology. Further on the methodology is repeated with the interventions to demonstrate how integration is to be achieved.

Box J.1 - To minimize compaction:

- The dump trucks should only operate on the 'basal'/non-soil layer, and their wheels must not in any circumstances run on to the soil layer(s)
- The machines are to only work when ground conditions enable their efficient operation
- The soils are to be replaced by the bulldozer in as thick layer as possible whilst maintaining their operational efficiency
- The bulldozer should make the minimal number of passes over the soil as possible
- The soil layers are to be in 'dry' condition.

Box J.2 - To minimize the wetness of the soil and re-wetting of the soil:

- Measures are required to protect the face of the soil layer from ponding of water and maintain the basal layer in a condition capable of supporting dump trucks.
- The area to be replaced is to be protected from in-flow of water, ponding etc. Wet sites should be drained in advance.

J.1 Key operational points to minimize the risk of severe soil compaction and soil wetness are summarised in Boxes J.1 and J.2.

J.2 The timing of soil handling operations in England and Wales is set out in **Part One, Supplementary Note 4**. For directly placed soils this will use the in situ soil wetness protocol for soil stripping operations to determine the timing for soil replacement (Box J.3). For soil that has been stored, the relaying operation should be governed by the

Box J.3 - Test for Dry and Friable Soils

Soil tests are to be undertaken in the field. Samples shall be taken from at least five locations on the soil handling area and at each soil horizon to the full depth of the profile to be recovered/replaced. The tests shall include visual examination of the soil and physical assessment of soil consistency.

i) Examination

- If the soil is wet, films of water are visible on the surface of soil particles or aggregates (e.g. clods or peds) and/or when a clod or ped is squeezed in the hand it readily deforms into a cohesive 'ball' means **no soil handling to take place**
- If the sample is moist (i.e. there is a slight dampness when squeezed in the hand) but it does not significantly change colour (darken) on further wetting, and clods break up/crumble readily when squeezed in the hand rather than forming into a ball means **soil handling can take place**
- If the sample is dry, it looks dry and changes colour (darkens) if water is added, and it is brittle means **soil handling can take place**

ii) Consistency

First Test

Attempt to mould soil sample into a ball by hand:

- Impossible because soil is too dry and hard or too loose and dry means soil handling can take place
- Impossible because the soil is too loose and wet means no soil handling to take place
- Possible - GO TO SECOND TEST

Second Test

Attempt to roll ball into a 3mm diameter thread by hand:

- Impossible because soil crumbles or collapses means **soil handling can take place**
- Possible means **no soil handling to take place**

NB: It is impossible to roll most coarse loamy and sandy soils into a thread even when they are wet. For these soils, the Examination Test alone is to be used.

weather (rainfall) criteria set out in Box J.4. Here, the operation will generally need to be completed no later than the end of September unless the establishment of a satisfactory vegetation cover can be assured.

J.3 Soil handling is not to take place during rain, sleet or snow and in these conditions should be prohibited if unsafe for machine operations. Prior to commencing operations, a medium/long term weather forecast should be obtained which gives reasonable confidence of soil handling being completed without significant interruptions from rainfall events. The criteria set out in Box J.3 are to be used to determine whether soil handling should cease or be interrupted with the occurrence of rain.

J.4 All machines must be in a safe and efficient working condition at all times. The machines are only to work when ground conditions enable their efficient operation. The work should only be carried out when the basal layer supports the machinery without ruts or is capable of repair/maintenance. Otherwise the operation is to be suspended until suitable remedial measures can be put in place.

Box J.4 - Rainfall Criteria:

- In light drizzle soil handling may continue for up to four hours unless the soils are already at/near to their moisture limit
- In light rain soil handling must cease after 15 minutes
- In heavy rain and intense showers, handling shall cease immediately.

In all of the above, after rain has ceased, soil tests shall be applied to determine whether handling may re-start, provided that the ground is free from ponding and ground conditions are safe to do so.

J.5 The operation should follow the detailed soil plan set out in the SRMP showing soil units to be replaced, haul routes and the phasing of vehicle movements. Different soil units to be kept separate are to be marked out and information to distinguish types and layers, and ranges of thickness needs to be conveyed to the operational supervisor/operator. The haul routes and soil storage areas must be defined and should be replaced in a similar manner.

Detailed daily records should be kept of operations undertaken, and site and soil conditions.

Box J.5

Whilst there can be a lower of a risk of compaction when using wide tracked ('low ground pressure' (LGP)) bulldozers, in some circumstances they may require to traffic the soil surface more than standard machines to achieve the same work rate, and therefore the advantage of their use may be less than anticipated. However, the risk of severe compaction and reliance on remedial treatments may be less with the use of LGP machines.

J.6 Within each soil unit the soil layers above the base/formation layer are to be replaced using a bulldozer to spread the soil layer by layer in advancing strips/blocks until all the soil is replaced. The bulldozer is only to stand and work on the soil layer when replacing the soils, otherwise it is to travel only on the basal layer. The dump trucks in this practice only operate on the basal layer.

Box J.6 - Soil Profiles Greater Than 1m Thickness

When the replaced soil profiles reach about 1m in height from the basal layer it may not be possible to discharge the load from smaller dump trucks directly onto the previously placed lower layers because of the height of the dump truck body. The preferred solution is to tip the soil against the partially completed profile as heaps without the dump trucks rising onto or reversing into the placed material. The soil material is then lifted by the excavator onto the profile. It is considered preferable to accept some limited soil losses rather than to contaminate the topsoil with overburden. The loss of top-soil is minimised if the basal/formation layer is kept to level and clean.

J.7 Demarcate the width of the strip to be soiled and the width of the replaced soil strip is the effective push distance of the bulldozer (Box J.5). Profile boards should be used to control soil horizon thickness being replaced and overall levels achieved verified using soil pits.

J.7 The dump truck tips the soil load on the front of the advancing face and the bulldozer pushes out the tipped subsoil to its full and final thickness with the minimum distance and number of pushes (**Figures J.1 & J.2**). The procedure is repeated until the strip of the subsoil layer is replaced.

Box J.7 - Integration of Decompaction & Stone/Debris Removal

Option 1: is where the basal layer needs to be treated but is left until the subsoil is placed when both are decompacted together, followed by the decompaction of the topsoil and subsoil layers together (and basal layer) using tines that are long enough. This option is not suited to digging where the soil horizons would be mixed.

Option 2: is where each layer is treated separately by either tines or digging.

Option 3: is where the basal layer is treated or left untreated, followed by the placement of the subsoil and topsoil layers, which are to be decompacted by the use of tines. In the case of deep horizons this option can be limited by the capability of the machinery, the tines or bucket used. This option is not suited to digging where the soil horizons would be mixed.

J.8 On completion of the width of the subsoil strip/block, the topsoil is tipped on its leading edge and pushed out to the final thickness with the minimum number of pushes (**Figure J.3**). This is repeated to advance topsoil coverage until the entire strip is soiled (see Box J.6 where soil profile is greater than 1m thickness).

J.9 Where the replacement operation is likely to be interrupted by rain, the topsoil layer should be placed before rain occurs and at the end of each day. Should this not be possible the subsoil layer is

to be 'sealed' by a low ground pressure bulldozer tracking and 'blading' of the exposed surface. Make provisions to protect base of current or next strip from ponding/runoff by sumps and grips, and also clean and level the basal layer. At the start of each day ensure there is no ponding in the current strip or operating areas, and the basal layer is to level with no ruts.

Methodology with Remedial Actions

J.10 The following is the model methodology using bulldozers with dump trucks and the modified layer by layer practice with the remedial interventions to demonstrate how integration is to be achieved. The key operational points to minimize the risk of severe soil compaction and soil wetness are summarised in Boxes J.1 and J.2 above.

J.11 Usually there will be a need for decompaction treatment during the replacement operation with this methodology. The placement of the stripped soils in storage is likely to result in greater compaction. Where compaction occurs, treatment will need integrating into the replacement process as will any need for the removal of stones or non-soil debris. Both decompaction and removal of materials are covered in separate **Sheets L to O**.

J.12 Box J.7 sets out some of the remedial options/combinations to facilitate removal of stones and decompaction.

J.13 Prior to work commencing a weather forecast should be obtained which gives reasonable confidence of soil replacement proceeding without interruptions from rainfall events (see Box J.4).

J.14 If significant rainfall occurs during operations, the replacement must be suspended, and where the soil profile has been started it should be replaced to the topsoil level. Replacement must not restart unless the weather forecast is expected to be dry for at least a full day and the soils are in a dry condition (see above Box J.3).

J.15 All machines must be in a safe and efficient working condition at all times. The machines are only to work when ground conditions enable their efficient operation. The work should only be carried

out when the basal layer supports the machinery without ruts or is capable of repair/maintenance. Otherwise the operation is to be suspended until suitable remedial measures can be put in place.

J.16 The operation should follow the detailed replacement plan in the SRMP showing the soil units to be replaced, haul routes and the phasing of vehicle movements. The soil units should be defined on the site with information to distinguish types and layers, and thickness and conveyed to the operational supervisor/operator. Different soil units to be kept separate are to be marked out and information to distinguish types and layers, and ranges of thickness needs to be conveyed to the operational supervisor/operator. Detailed daily records should be kept of operations undertaken and site and soil conditions (including the removal of stones and other non-soil debris that needs to be removed), and the results of the effectiveness of the work undertaken, and any need for additional remedial treatments.

J.17 Within each soil unit the soil layers above the base/formation layer are to be replaced layer by layer in advancing strips until all the soil is replaced. The haul routes and storage areas must be defined and should be replaced last in a similar manner.

J.18 Profile boards should be used to control soil horizon thickness being replaced and overall levels achieved verified using soil pits. Allowances (ie. bulking factor) should be made for any 'heave' that may take place when the replaced soil is decompacted.

J.19 Only the bulldozer is to stand and work on the soil layer when replacing the soils, otherwise it is to travel on the basal layer.

J.20 Where there is a requirement to treat compaction and/or remove stones/non-soil debris in the basal layer, these need to be carried out prior to the first layer of soils being laid. Decompaction can be done by digging with the excavator bucket or by bulldozer drawn tines (**Sheets N & O**). Stone removal may require prior ripping/digging to release them from the soil, followed by the excavator using a stone-rake bucket (to be loaded on a dump truck and removed)

(**Sheets L & M**).

Where these treatments are deployed, to minimise additional compaction/recompaction, only the bulldozer need to work and traffic the basal layer and the soil surfaces, and the excavator and the dump truck being loaded with the recovered stones/debris stand and travel on the untreated basal layer.

J.21 On completion of the remedial work, the subsoil is spread with the bulldozer pushing out the soil, tipped at the edge of the treated basal layer to cover it to the required depth (**Figures J.1 & J.2**). The dump trucks should avoid reversing onto the treated basal layer to minimize severe recompaction of the basal layer.

J.22 On completion of the subsoil placement and where there is a requirement to treat compaction and/or remove stones and non-soil debris in the subsoil, these need to be carried out prior to the topsoil layer of soil being laid. Decompaction can be done by digging with the excavator bucket or by bulldozer drawn tines (**Sheets N & O**). Stone removal may require prior ripping/digging to release them from the subsoil, followed by the excavator using a stone-rake bucket (**Sheets L & M**). Where these treatments are deployed, to minimise additional compaction/recompaction, only the bulldozer need to work and traffic the subsoil layer, and the excavator and the dump truck being loaded with the recovered stones/debris stand and travel on the untreated basal layer.

J.23 On completion of the subsoil remediation works the topsoil replacement begins. The dump truck tip the topsoil on to the advancing edge of the subsoiled strip (see also Box J.6) for the bulldozer to push out to its final thickness with the minimum distance and number of pushes (**Figure J.3**). The procedure is repeated across the area to be soiled until it is completed.

J.24 Where there is a requirement to treat compaction and/or remove stones and non-soil debris in the topsoil, decompaction can be done by digging with the excavator bucket or by bulldozer drawn tines (**Sheets N & O**).

Stone removal may require prior ripping/digging to release them from the topsoil, followed by the excavator using a stone-rake bucket (to be loaded on a dump truck and removed) (**Sheets L & M**). Where these treatments are deployed, to minimise additional compaction/recompaction, only the bulldozer need to work and traffic the topsoil, and the excavator and the dump truck being loaded with the recovered stones/debris stand and travel on the untreated basal layer.

J.25 Whilst remedial treatment is generally limited to the bulldozer option (**Sheets M & O**), because of the risk of further compaction from the excavator and dump truck option (**Sheets L & N**), it is possible to arrange for the operations so that there is minimal trafficking and the retreating excavator treats any compacted areas.

J.26 There is also the option of ripping with bulldozer tines (**Sheet O**) to treat compaction in the top- and subsoil layers together (Box J.7, Option 3). Here, stone and non-soil debris removal would be restricted to the topsoil layer. However, this Option is only advisable where it is certain that it will be effective.

J.27 On completion of the replacement of the full soil profile in the strip, the next is formed with the process being repeated until the area to be soiled has been completed.

J.28 Where the replacement operation is likely to be interrupted by rain or there is likely to be overnight rain, the exposed subsoil and topsoil layers are to be 'sealed' by the bulldozer tracking and 'blading' the exposed surface. Make provisions to protect base of current or next strip from ponding/runoff by sumps and grips, and also clean and level the basal layer. At the start of each day ensure there is no ponding in the current strip or operating areas, and the basal layer is to level with no ruts.

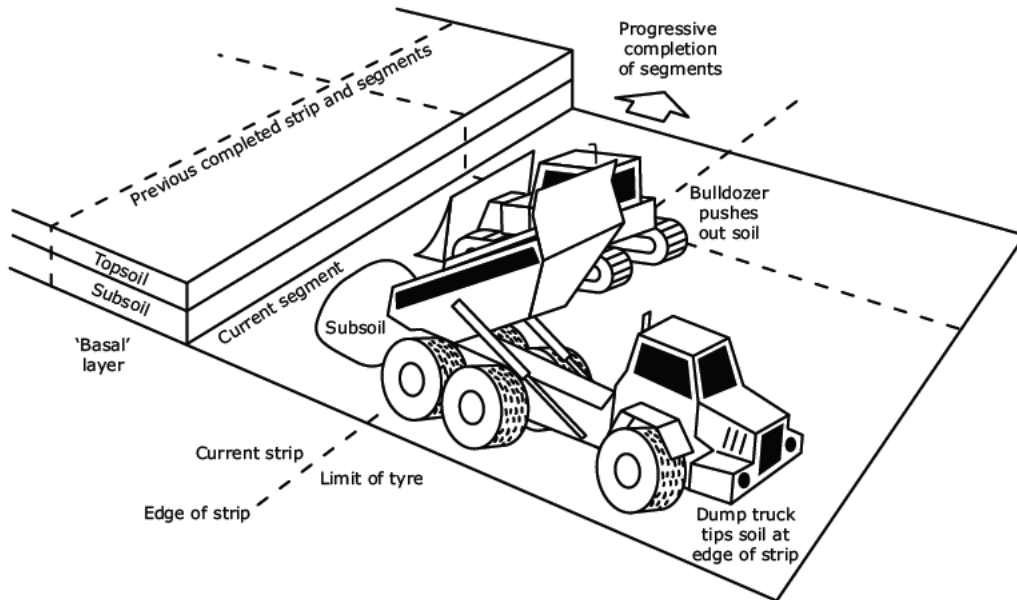

Figure J.1: Soil replacement with bulldozer and dump truck using modified layer by layer method: Subsoil.

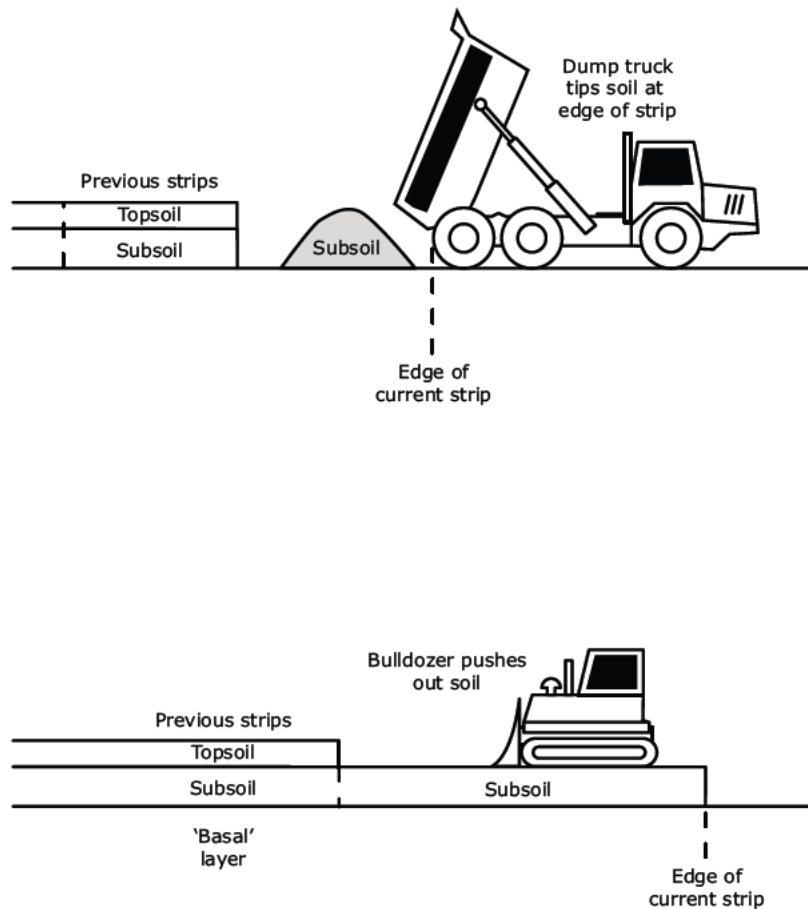

Figure J.2: Soil replacement with bulldozers and dump trucks using modified layer by layer method: Subsoil.

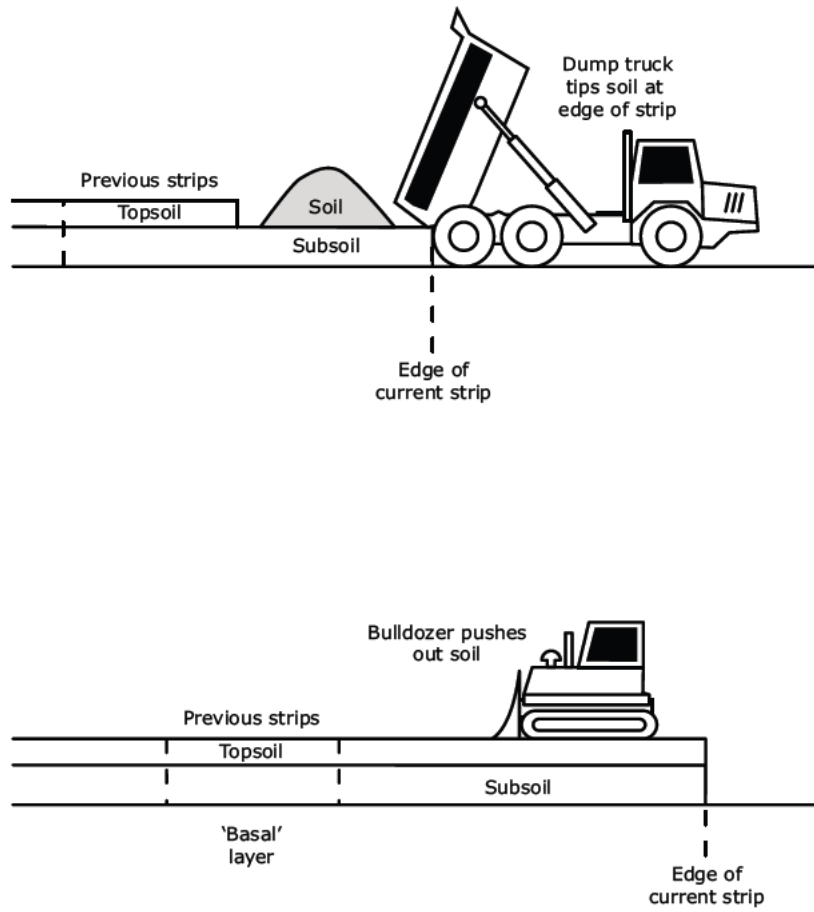

Figure J.3: Soil replacement with bulldozers and dump trucks using modified layer by layer method: Topsoil.

GOOD PRACTICE GUIDE FOR HANDLING SOILS

In Mineral Workings

PART TWO: Model Methodology

- Sheet K -

Hybrid Soil Replacement with Excavators, Bulldozers and Dump Trucks
- Modified Layer by Layer Practice

Author: Dr R N Humphries CBiol CSci FRSB FBSSS FIQ
- Blakemere Consultants Ltd & Celtic Energy Ltd

Supporting artwork was provided by R Shelton (H J Banks & Co)
and D Fisher (Blue Room Graphics Ltd).

Preface

The purpose of Sheet K of the guidance is to provide a model method of best practice where the hybrid combination of excavator and bulldozer with dump trucks are to be used to replace soil using the modified 'layer by layer' practice.

The guidance is intended for use by planning officials, statutory consultees, mineral operators and their supporting teams and specialist consultants, and earth-moving contractors, their site supervisors and machine operators.

Successful soil handling schemes are dependent on the soil resources being clearly identified and the conditions in which they are to be handled. This information should be contained in the Soil Resource & Management Plan (SRMP) and communicated to those involved in its implementation.

Key issues to be addressed are:

- i) Avoiding conditions when soils are wet/plastic during handling
- ii) The minimisation of soil compaction caused by trafficking and soil wetness
- iii) Using appropriate remedial treatments where these are necessary
- iv) Minimising soil loss, and mixing of soil layers or different soil types.

The SRMP should specify the type of earth-moving machinery and soil handling practice, and the soil wetness condition (see Part One of the Guidance) to be deployed to achieve the planned after use, soil functioning, and the environmental and ecosystem services. It is to be communicated in full to all involved and in particular to the supervisors and machine operators by appropriate means; including tool-box talks and site demonstrations. Supervision by trained supervisory staff is essential, as are monitoring and reporting.

The guidance does not specify the size or model of equipment as this is left to the mineral operator and contractor to specify and provide. The machines must be of a kind which are appropriate for the task and the outcomes required, and to be able to carry

out the work safely and efficiently.

Should the agreed methodology need to be modified or changed significantly, this should be agreed in advance with the mineral planning authority. The SRMP should include a mechanism whereby unexpected less significant changes can be quickly resolved through consultation between the operator, the planning authority and statutory consultee, and soil specialist.

All persons involved in the handling of soils must comply with all relevant legislation with respect to Health and Safety, in particular the Health and Safety at work Act 1974 and in the case of mineral extraction operations, The Quarries Regulations 1999 and its relevant statutory provisions; in particular those aspects which relate to the construction and removal of tips, mounds and similar structures. These requirements take preference over any suggested practice in this Sheet and the SRMP should have taken these into account.

The users of this guidance are solely responsible for ensuring it complies with all safety legislation and good practice, including the manufacturer's specifications for the safe operation of the specific machines being used, and that all machines are in a good condition and well maintained and are suitable for the task. It is important that those involved in the operation of earth moving machines are competent and have the necessary training and certification.

Introduction

In this soil handling option, back-acting excavators are used to replace the subsoil resources tipped from dump trucks and, specifically low ground pressure bulldozers, are used to spread the topsoil layer. It is referred to as a version of loose soil tipping in [DEFRA's Construction Code of Practice for the Sustainable Use of Soils on Construction Sites](#).

The practice involves the sequential building up of the soil layer(s) identified in the Soil Resource & Management Plan (SRMP) using an excavator to spread the subsoil to final level and a bulldozer to spread the topsoil.

The subsoil is placed first as a series of advancing strips within the safe and efficient operational reach of the excavator boom which defines the width of each successive subsoil strip. On the completion of each subsoil strip before the next is soiled, the topsoil is tipped onto the subsoil for spreading by the bulldozer later.

This method differs from the standard excavator method (Sheet D) in that the topsoil is spread by a bulldozer and over a layer of subsoil.

The procedure for spreading of the topsoil is similar to the practice set out in [MAFF 2000, Sheet 15](#).

It is a preferable practice to the bulldozer windrow/peninsular method set out in Sheet H as the dump trucks do not traffic the topsoil and risk causing additional severe compaction.

Unlike the stripping and storage practices, the replacement of soils is usually in concert with other work to remediate soil conditions such as compaction (**Sheets N & O**) and removal of stones/non-soil debris (**Sheets L & M**). These actions have their own practices which need to be integrated into this model methodology of soil handling. The need for these will have been specified in the SRMP and/or in the soil replacement conditions attached to the planning consent, or as determined by the soil specialist during the soil stripping/storage/replacement operations.

The following guidance is only relevant to multiple layered soils.

Advantages & Disadvantages

The advantages of this machinery combination and handling practice are several:

- i) Provided the soils are not put into storage mounds, it may result in soil profiles with the less compacted (upper) subsoils which may not require remedial treatment or only minimal of action
- ii) It can be easy to create localised changes in subsoil types and variation in horizon depth
- iii) It is likely to result in less soil loss and mixing than the excavator only practice
- iv) The layer by layer system may be quicker to complete than the bed/strip only practice, provided that remedial treatments are not required of the subsoil
- v) It can be moderately flexible in responding to stoppages and restarts due to wet weather
- vi) There is some certainty that a transpiring vegetation cover can be established during the soil replacement programme.

The disadvantages are several:

- i) The deployment of two different handling methods requires a high level of supervision, skill and discipline in its deployment, and is best suited to experienced operators
- ii) There is risk of compaction of the top- and upper subsoil layers by the repeated trafficking of the bulldozer, even if a low ground pressure machine is used. Hence, subsequent remedial treatments are likely to be relied upon
- iii) It is slower than both the excavator combination with the bed/strip and windrow practices because of the dual handling practices
- iv) Without good control and regular monitoring of soil layer depths, use of profile boards or machine fitted GPS it can be harder to gauge the rate of use of subsoil resource
- v) It is not suited both to the replacement of low bearing strength soils (eg peat & organic topsoil), and thin and 'patterned' topsoil layers
- vi) Where remedial work is relied upon, the

- sequential tipping of topsoil and the laying of the next subsoil strip will have to be delayed until the strip in question is treated
- vii) Steep gradient/complex topographies may limit the safe and practical deployment of this handling practice.

- replacement, effective remedial treatment may have to be relied upon
- iv) The soils have been placed into storage stockpiles
- v) It is more suited to southern and eastern, and lowland locations, and particularly when there are the more certain weather patterns.

Suitability

The hybrid excavator-bulldozer and dump truck combination with the modified layer by layer handling practice methodology is considered by DEFRA as an acceptable alternative practice to loose tipping. However, there is a risk of compaction in the topsoil layer and in the underlying (upper) subsoil, and the implementation of remedial treatments may be restrictive. As it is more reliant on remedial treatment than the standard excavator method (**Sheet D**), it is also more dependent on the soils being in a dry condition. Because of this it is considered only suitable for medium and highly resilient soils (see **Table 7 in Part One and Supplementary Notes 3 & 4**), and should not be considered an alternative to the excavator only practice (**Sheet D**) without justifiable reasons.

Whilst the hybrid method is not considered to be the 'best practice', it may be acceptable in circumstances where

- i) The subsoil(s) are of medium to high resilience to compaction (see **Table 7 in Part One, and Supplementary Notes 3 & 4**) and when decompaction treatments can be more relied upon to be effective because of i) a lower risk of soil wetness (low rainfall areas/prolonged dry conditions) and/or ii) the availability of effective decompaction tools
- ii) The limitations of compaction and stones/debris is restricted to the topsoil layer
- iii) The intended after use, and environmental and ecosystem services are less dependent on maintaining functional characteristics such as soil porosity and hence drainage and aeration, plant available water capacity, and low resistance to plant root growth. This may include the less productivity agricultural and forestry land, some types of natural habitats, and where water storage/infiltration is of less importance for the risk of flooding. Where the soils are stored prior to

MODEL METHODOLOGY

Basic Soil Replacement Operation

K.1 The following is the basic model methodology using the hybrid method of excavators, bulldozers and dump trucks with a modified layer by layer practice. It is presented here, firstly without any remedial interventions to give clarity of the methodology. Later the methodology is repeated to demonstrate how the interventions can be integrated into the soil replacement process.

K.2 Key operational points to minimise the risk of severe soil compaction and soil wetness are summarised in Boxes K.1 and K.2.

Box K.1 - To minimize compaction:

- The bulldozer is to only operate on the topsoil
- The dump trucks should only operate on the 'basal'/non-soil layer and not run on the replaced soil layer(s)
- The excavator must only operate on the basal layer
- The machines are to only work when ground conditions enable their efficient operation
- The bulldozer should make the minimal number of passes over the soil as possible
- If compaction has been caused, then measures are required to treat it (see **Sheets N & O**)

Box K.2 - To minimise soil wetness and re-wetting:

- The modified layer by layer system provides a basis to regulate the exposure of lower soil layers to periods of rain and a means of maintaining soil moisture contents. The soil profile within the active strip should be completed including the topsoil layer before rainfall occurs and before replacement is

suspended

- measures are required to protect the face of the soil layer from ponding of water and maintain the basal layer in a condition capable of supporting dump trucks
- The area to be restored is to be protected from in-flow of water, ponding etc. Wet sites must be drained in advance. Before the operation starts the basal layer should be to level and clean.

K.3 The timing of soil handling operations in England and Wales is set out in **Part One, Supplementary Note 4**. For directly placed soils this will use the in situ soil wetness protocol for soil stripping operations to determine the timing for soil replacement (Box K.3). For soil that has been stored, the relaying operation should be governed by the weather (rainfall) criteria set out in Box K.4. Here, the operation will generally need to be completed no later than the end of September unless the establishment of a satisfactory vegetation cover can be assured.

K.4 Soil handling is not to take place during rain, sleet or snow and in these conditions should be prohibited if unsafe for machine operations. Prior to commencing operations, a medium/long term weather forecast should be obtained which gives reasonable confidence of soil handling being completed without significant interruptions from rainfall events. The criteria set out in Box K.4 are to be used to determine whether soil handling should cease or be interrupted with the occurrence of rain.

K.5 All machines must be in a safe and efficient working condition at all times. The machines are to only work when ground conditions enable their efficient operation. The work should only be carried out when the basal layer supports the machinery without ruts or is capable of repair/maintenance. Otherwise the operation is to be suspended until suitable remedial measures can be put in place.

K.6 The operation should follow the detailed SRMP replacement plan showing the soil units to be replaced, haul routes and the phasing of vehicle movements. The soil units should be defined on the site with information to distinguish types and layers, and thickness and conveyed to the operational supervisor/operator. Different soil units to be kept

Box K.3 - Test for Dry and Friable Soils

Soil tests are to be undertaken in the field. Samples shall be taken from at least five locations on the soil handling area and at each soil horizon to the full depth of the profile to be recovered/replaced. The tests shall include visual examination of the soil and physical assessment of soil consistency.

i) Examination

- If the soil is wet, films of water are visible on the surface of soil particles or aggregates (e.g. clods or peds) and/or when a clod or ped is squeezed in the hand it readily deforms into a cohesive 'ball' means **no soil handling to take place**
- If the sample is moist (i.e. there is a slight dampness when squeezed in the hand) but it does not significantly change colour (darken) on further wetting, and clods break up/crumble readily when squeezed in the hand rather than forming into a ball means **soil handling can take place**
- If the sample is dry, it looks dry and changes colour (darkens) if water is added, and it is brittle means **soil handling can take place**

ii) Consistency

First Test

Attempt to mould soil sample into a ball by hand:

- Impossible because soil is too dry and hard or too loose and dry means soil handling can take place
- Impossible because the soil is too loose and wet means no soil handling to take place
- Possible - GO TO SECOND TEST

Second Test

Attempt to roll ball into a 3mm diameter thread by hand:

- Impossible because soil crumbles or collapses means **soil handling can take place**
- Possible means **no soil handling to take place**

NB: It is impossible to roll most coarse loamy and sandy soils into a thread even when they are wet. For these soils, the Examination Test alone is to be used.

Box K.4 - Rainfall Criteria:

- In light drizzle soil handling may continue for up to four hours unless the soils are already at/near to their moisture limit
- In light rain soil handling must cease after 15 minutes
- In heavy rain and intense showers, handling shall cease immediately.

In all of the above, after rain has ceased, soil tests shall be applied to determine whether handling may re-start, provided that the ground is free from ponding and ground conditions are safe to do so.

separate are to be marked out and information to distinguish types and layers, and ranges of thickness needs to be conveyed to the operational supervisor/machine operator. Detailed daily records should be kept of operations undertaken and site and soil conditions.

K.7 Profile boards should be used to control soil horizon thickness in each strip and overall levels achieved verified using soil pits. Allowances (i.e. a bulking factor) should be made for any settlement that may take place of the replaced loose soil.

K.8 The excavator and dump trucks are only to stand, work and travel on the basal/formation layer, and the bulldozer is to only operate on the topsoil after it is tipped onto the subsoil.

K.9 The excavator placed strip width and axis is to be demarcated. The strip width is determined by excavator boom length less the stand-off to operate; typically, about 3-4m (Box K.5). Excavators with long booms ('long reach') can be used, but may be more restricted by gradient limitations, and require skilled and experienced operators.

K.10 The type of bucket to be used largely depends on the nature of the soil (Box K.6).

K.11 The number of subsoil strips to be soiled before the sequentially tipped topsoil (**Figure K.3**) is spread to final level over the subsoil layer depends on the

Box K.5 - Orientation of the Excavator

Usually, the excavator is orientated and operates with its tracks at 90° to the axis of the strip being replaced as this is the most stable operating position.

Whilst the reach of the boom and hence the width of the bed/strip can be significantly increased by orientating it with the tracks parallel to edge of the soil being spread, this may affect the stability of the excavator, particularly on a gradient or where the basal layer has a low bearing capacity. Hence, its safe deployment needs to be checked before its adoption.

Box K.6 - Choice of Bucket Type

For hard /stony soils toothed buckets are needed. Where the mixing of soil layers at their interface is to be minimized, a bucket with a 'blade' is preferable where the soil is 'soft' and free of large stones or particularly stony stone free. Where there is a watching archaeological brief, the use of bladed buckets will normally be required.

Similarly, the choice of bucket type, whether it is a standard 'digging'/bulking or wide ditching type will depend on the soil strength and stoniness. The preferred type of bucket to place the subsoils is usually a digging/bulking bucket with an attached blade or a wide ditching bucket, but a toothed bucket can be used.

soiling capacity for the day's work as no subsoil should be left uncovered.

K.12 The dump truck reverses up to edge of the first strip to be subsoiled and tips the subsoil, without the wheels riding onto the basal layer (**Figures K.1 & K.2**). The dump truck should not drive away until all the subsoil is deposited within the strip without spillage; this may require assistance from the excavator to 'dig away' some of the tipped soil. The excavator is to spread the tipped subsoil to full thickness by digging, and using the pushing and pulling action of bucket.

K.13 Each load of subsoil should be spread following tipping before another is tipped. Should the spread soil comprise of large blocks (>300mm), normally these should be broken down by using the excavator bucket into smaller pieces before the next load is spread. The process is repeated until the strip is completely covered with the required depth of the subsoil layer.

K.14 On completion of the first subsoil strip, the topsoil needed to cover the soiled strip is to be tipped onto the subsoil. The dump truck reverses up to edge of the subsoil strip and tips the topsoil, without the wheels riding onto the subsoil (**Figure K.3**). The dump truck should not drive away until all the soil is deposited within the strip without spillage (see Box K.7); this may require assistance from the excavator to 'dig away' some of the tipped soil. The topsoil is to be spread to final depth after the completion of the further strips of subsoil (**Figure K.3**).

Box K.7 - Soil Profiles Greater Than 1m Thickness

When the replaced soil profiles reach about 1m in height from the basal layer it may not be possible to discharge the load from smaller dump trucks directly onto the previously placed lower layers because of the height of the dump truck body. The preferred solution is to tip the soil against the partially completed profile as heaps without the dump trucks rising onto or reversing into the placed material. The soil material is then lifted by the excavator onto the profile. It is considered preferable to accept some limited soil losses rather than to contaminate the topsoil with overburden. The loss of top-soil is minimised if the basal/formation layer is kept to level and clean.

K.15 On completion of the first subsoil strip and tipping the topsoil, repeat the process until sufficient strips have been placed to provide an adequate area for the bulldozer to work efficiently in spreading the topsoil to the final depth (**Figure K.3**).

K.16 At the end of each day the current strips should be completed if rain is forecast. If during a day it is evident that a full strip cannot be completed, then

complete the part of a strip that has been started to final topsoil level.

K.17 At the end of each day, or during the day if interrupted by rain, make provisions to protect base of restored strip from ponding/runoff by sumps and grips, and also clean and level the basal layer. At the start of each day ensure there is no ponding in the current strip or operating areas, and the basal layer is to level with no ruts.

Method with Integration of Remedial Actions

K.18 The following is the model methodology using the hybrid excavator, bulldozer and dump truck practice with the remedial interventions to demonstrate how integration is to be achieved. The key operational points to minimize the risk of severe soil compaction and soil wetness are summarised in Boxes K.1 and K.2 above.

K.19 Usually there will be a need for remedial treatment during the replacement operation with this machinery combination and handling practice. The placement of the stripped soils in storage is very likely to result in the need for remedial treatment. Where compaction occurs, treatment will need integrating into the replacement process as will any need for the removal of stones or non-soil debris. Both decompaction and removal of materials are covered in separate **Sheets L to O**. Where required, the early installation of under drainage can either be integrated sequentially during the replacement of the soils or later during the aftercare period.

K.20 Box K.8 sets out some of the remedial options/combinations to facilitate decompaction, and where necessary, the removal of stones and non-soil debris for a final profile comprising a basal layer, subsoil and topsoil layers. Except for Option 3, these actions need to be undertaken sequentially as each soil strip is placed.

K.21 Prior to commencing operations a weather forecast should be obtained which gives reasonable confidence of soil replacement proceeding without interruptions from rainfall events (Box K.4).

Box K.8 - Integration of Decompaction & Stone/Debris Removal

Option 1: is where the basal layer needs to be treated but is left until the subsoil is placed when both are decompacted together, followed by the decompaction of the topsoil and subsoil layers together (and basal layer) using tines that are long enough. This option is not suited to digging where the soil horizons would be mixed.

Option 2: is where each layer is treated separately by either tines or digging.

Option 3: is where the basal layer is treated or left untreated, followed by the placement of the subsoil and topsoil layers, which are to be decompacted by the use of tines. In the case of deep horizons this option can be limited by the capability of the machinery, the tines or bucket used. This option is not suited to digging where the soil horizons would be mixed.

K.22 If significant rainfall occurs during operations, the replacement must be suspended, and where the soil profile has been started it should be replaced to top-soil level. Replacement should not restart unless the weather forecast is expected to be dry for at least a full day and the soils are in a dry condition (Box K.3).

K.23 The operation should follow the detailed replacement plan in the SRMP showing the soil units to be replaced, haul routes and the phasing of vehicle movements. The soil units should be defined on the site with information to distinguish types and layers, and thickness and conveyed to the operational supervisor/operator. Different soil units to be kept separate are to be marked out and information to distinguish types and layers, and ranges of thickness needs to be conveyed to the operational supervisor/operator. Detailed daily records should be kept of operations undertaken and site and soil conditions (including the removal of stones and other non-soil debris that needs to be removed), and the results of the effectiveness of the work undertaken, and any need for additional remedial treatments.

K.24 Profile boards should be used to control soil horizon thickness in each strip and overall levels achieved verified using soil pits to verify. Allowances (i.e. a bulking factor) should be made for any settlement that may take place of the replaced loose soil.

K.25 The excavator and dump trucks are only to stand, work and travel on the basal/formation layer. Only where the remedial work involve the use of a bulldozer does machinery have to traffic the basal layer and subsoil(s) being treated, as the excavators work from the basal layer.

K.26 The initial strip width and axis is to be demarcated. Strip width is determined by excavator boom length less the stand-off to operate; typically, about 3-4m (see Box K.5). Excavators with long booms ('long reach') can be used, but may be more restricted by gradient limitations, and require skilled and experienced operators.

K.27 Where there is a requirement to treat compaction and/or remove stones/non-soil debris in the basal layer, these need to be carried out along the demarcated strip prior to the laying of subsoil.

K.28 Decompaction of the basal layer can be by digging with the excavator bucket (**Sheet N**) or by bulldozer drawn tines (**Sheet O**). Stone removal may require prior ripping/digging to release them from the basal material, followed by the excavator using a stone-rake bucket (the stone to be loaded on a dump truck and removed (**Sheet L**) or bulldozer with an excavator on the untreated basal layer loading the dump truck (**Sheet M**).

K.29 On completion of treating the basal layer, the loaded dump trucks reverse up to edge of the strip and tip the subsoil without the wheels riding onto the treated basal strip (**Figures K.1 & K.2**). The dump truck should not drive away until all the soil is deposited within the strip without spillage over the basal layer; this may require assistance from the excavator to 'dig away' some of the tipped soil. The excavator is to spread the tipped subsoil to full thickness by digging, and using the pushing and pulling action of bucket.

K.30 Each load of subsoil should be spread following tipping before another is tipped. Should the spread soil comprise of large blocks (>300mm), normally these should be broken down by using the excavator bucket to break the blocks into smaller pieces before the next load is spread. The process is repeated until the strip is completely covered with the required depth of the subsoil layer (**Figure K.2**).

K.31 The process of remedial treatment of the basal layer is repeated prior to each successive subsoil strip being soiled.

K.32 Where remedial treatment of the subsoil is required, either this is achieved one strip at a time (as for the basal layer) using excavators standing on the untreated basal strip (**Sheets L & N**) or by bulldozer methods (**Sheets M & O**) working on the subsoil surface where several strips are placed (see K.34 below).

K.33 Following the completion of the subsoil remedial treatments strip by strip, the topsoil is either tipped strip by strip when using the excavator options (**Sheets L & N**) or if several strips of subsoil are placed the topsoil is tipped along the final leading edge of the treated subsoil layer when using the bulldozer treatment options (**Sheets M & O**). In the latter the maximum number of subsoil strips to be soiled depends on the effective distance the low ground pressure bulldozer can push and spread the topsoil to depth the soil (with the minimal number of passes) from the advancing edge of the strips.

K.34 Where the remedial treatments are to be undertaken on the finished subsoil surface it is generally limited to the bulldozer option (**Sheets M & O**) because of the risk of further compaction from the excavator and dump truck option (**Sheets L & N**), although it is possible to arrange for the operations so that there is minimal trafficking and the retreating excavator treats any compacted areas. There is also the option of ripping with bulldozer tines (**Sheet O**) to treat compaction in the top- and subsoil layers together.

K.35 The sequentially tipped topsoil on the strips is pushed out to the final level of the subsoil by the minimal number of passes possible (**Figure K.3**) or

from the mound on the leading edge of a series of subsoil and treated strips.

K.36 Where there is a requirement for remedial treatments in the topsoil layer, this is undertaken on the finished topsoil surface.

Whilst it is generally limited to the bulldozer option (**Sheets M & O**) because of the risk of further compaction from the excavator and dump truck option (**Sheets L & N**), it is possible to arrange for the operations so that there is minimal trafficking and the retreating excavator treats any compacted areas. There is also the option of ripping with bulldozer tines (**Sheet O**) to treat compaction in the top- and subsoil layers together.

K.37 On completion of the topsoil layer the processes outlined above should be repeated for the next block of strips until the whole area to be restored is completed. Before the operation starts the basal layer should be to level and clean.

K.38 At the end of each day the current strip must be completed if rain is forecast. If during a day it is evident that a full strip cannot be completed, then complete the part of a strip that has been started.

K.39 At the end of each day, or during the day if interrupted by rain, make provisions to protect base of restored strip from ponding/runoff by sumps and grips, and also clean and level the basal layer. At the start of each day ensure there is no ponding in the current strip or operating areas, and the basal layer is to level with no ruts.

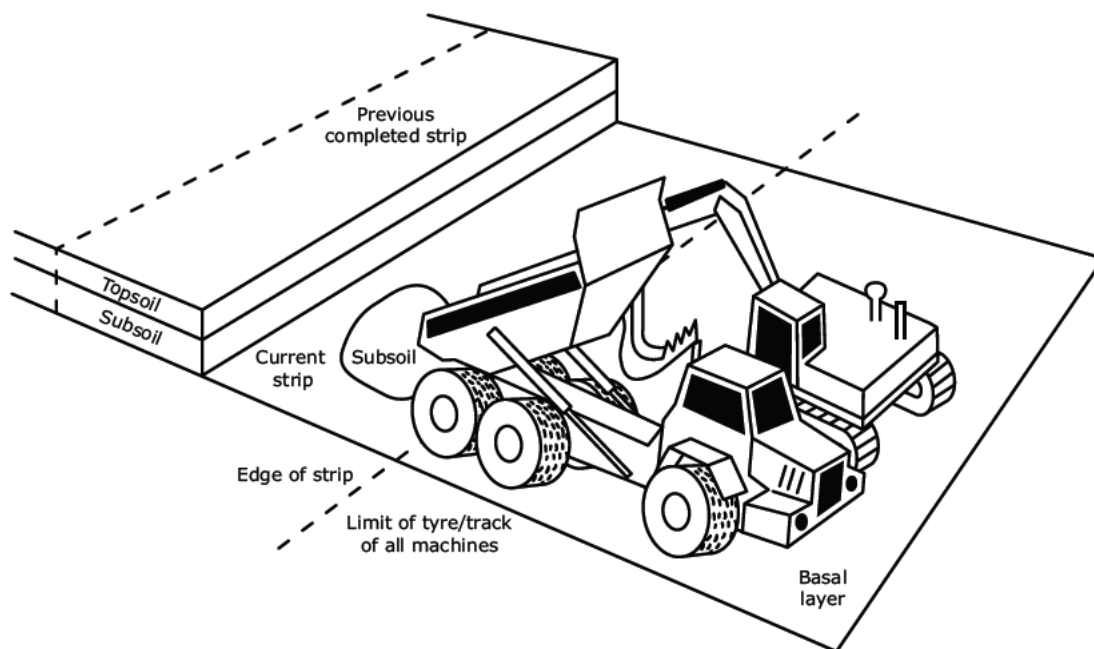

Figure K.1: Soil replacement with excavators and bulldozers using hybrid method: Subsoil.

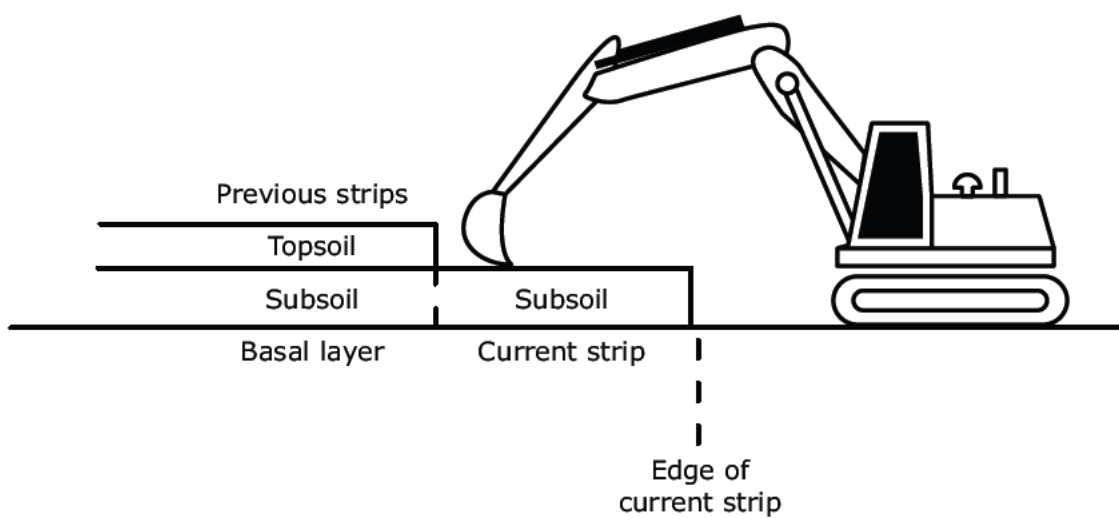

Figure K.2: Soil replacement with excavators and bulldozers using hybrid method: Subsoil.

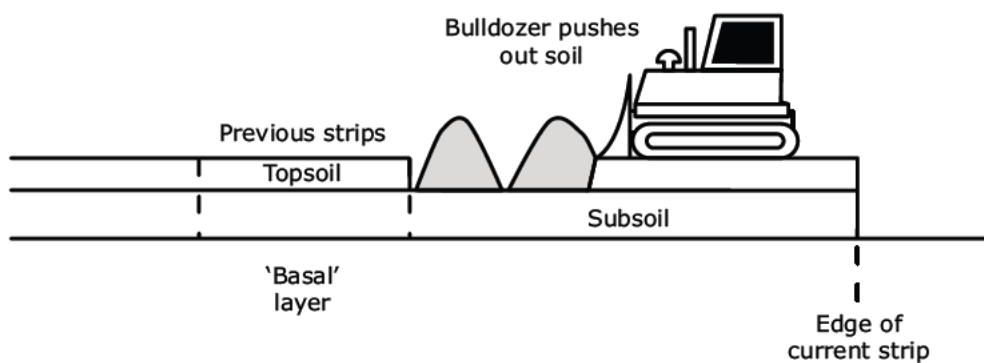
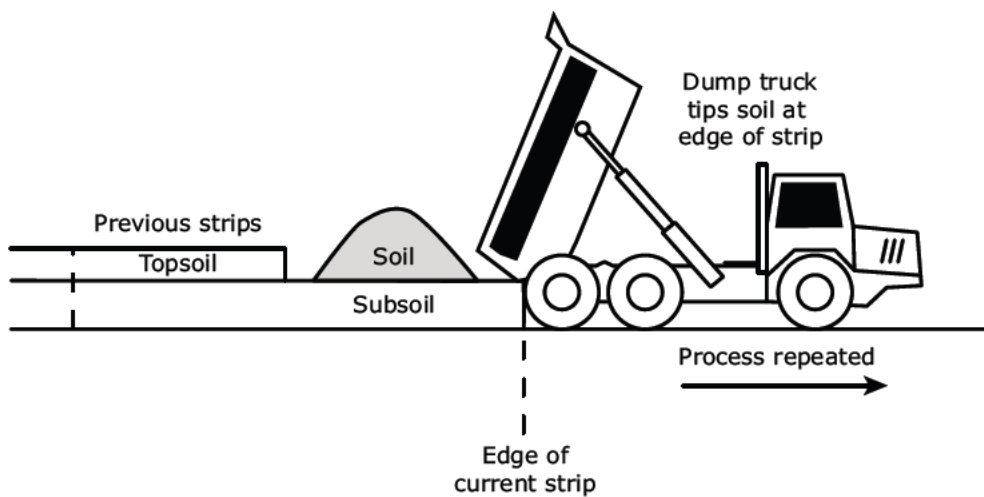

Figure K.3: Soil replacement with excavators and bulldozers using hybrid method: Topsoil.

GOOD PRACTICE GUIDE FOR HANDLING SOILS

In Mineral Workings

PART TWO: Model Methodology

- Sheet L -

Release & Removal of Stones and Non-Soil Debris
by Excavator & Stone-Rake

Author: Dr R N Humphries CBiol CSci FRSB FBSSS FIQ
- Blakemere Consultants Ltd & Celtic Energy Ltd

Supporting artwork was provided by R Shelton (H J Banks & Co)
and D Fisher (Blue Room Graphics Ltd).

Preface

The purpose of Sheet L of the guidance is to provide a model method of best practice where excavators are to be used to release and remove stones and non-soil debris from the basal layer and replaced soils.

The guidance is intended for use by planning officials, statutory consultees, mineral operators and their supporting teams and specialist consultants, and earth-moving contractors, their site supervisors and machine operators.

Successful soil handling schemes are dependent on the soil resources being clearly identified and the conditions in which they are to be handled. This information should be contained in the Soil Resource & Management Plan (SRMP) and communicated to those involved in its implementation.

Key issues to be addressed are:

- i) Avoiding conditions when soils are wet/plastic during handling
- ii) The minimisation of soil compaction caused by trafficking and soil wetness
- iii) Using appropriate remedial treatments where these are necessary
- iv) Minimising soil loss, and mixing of soil layers or different soil types.

The SRMP should specify the type of earth-moving machinery and soil handling practice, and the soil wetness condition (see Part One of the Guidance) to be deployed to achieve the planned after use, soil functioning, and the environmental and ecosystem services. It is to be communicated in full to all involved and in particular to the supervisors and machine operators by appropriate means; including tool-box talks and site demonstrations. Supervision by trained supervisory staff is essential, as are monitoring and reporting.

The guidance does not specify the size or model of equipment as this is left to the mineral operator and contractor to specify and provide. The machines must be of a kind which are appropriate for the task and the outcomes required, and to be able to carry out the work safely and efficiently.

Should the agreed methodology need to be modified or changed significantly, this should be agreed in advance with the mineral planning authority. The SRMP should include a mechanism whereby unexpected less significant changes can be quickly resolved through consultation between the operator, the planning authority and statutory consultee, and soil specialist.

All persons involved in the handling of soils must comply with all relevant legislation with respect to Health and Safety, in particular the Health and Safety at work Act 1974 and in the case of mineral extraction operations, The Quarries Regulations 1999 and its relevant statutory provisions; in particular those aspects which relate to the construction and removal of tips, mounds and similar structures. These requirements take preference over any suggested practice in this Sheet and the SRMP should have taken these into account.

The users of this guidance are solely responsible for ensuring it complies with all safety legislation and good practice, including the manufacturer's specifications for the safe operation of the specific machines being used, and that all machines are in a good condition and well maintained and are suitable for the task. It is important that those involved in the operation of earth moving machines are competent and have the necessary training and certification.

Introduction

The purpose of this Guidance Sheet is to provide a model method for best practice where stones and/or non-soil debris (e.g. wire rope, concrete blocks) are to be released using an excavator with a ripper claw and/or specialist stone-rake buckets from the basal layer and/or soils during replacement. The methodology can be deployed in combination with the machinery and practices presented in Sheets D, H, J and K.

Advantages & Disadvantages

The advantages are:

- i) It is an efficient means of removal of stones; and
- ii) It is very flexible with the quick interchange with digging bucket where needed for the removal of intransigent buried material
- iii) It can be an effective means of decompaction and cultivation of cloddy replaced soil
- iv) It serves to level the soil surfaces.

The disadvantages are:

- i) The effective reach of the excavator may limit the width of strips being treated or soils being placed
- ii) The effective release of stones from clayey soils is dependent on the soils being in a sufficiently 'dry' condition
- iii) The depth of release of material will be dependent on the length of the bucket's 'tines' (elongated teeth).
- iv) The size of stones is limited to the spacing of the bucket's 'tines' and may need different bucket sizes where a range of sizes are to be removed in successive soil layers
- v) There is a risk of removal of significant amounts of soil adhered to the stones and soil clods when they are hard and dry
- vi) There is a risk the removal of stones with dump trucks will result in the recompaction where trafficking the soil layers.

Suitability

This practice is the most suitable for a wide range of after uses and ecosystem services where stones are to be removed or the stone content is to be reduced, and it can be deployed on steep and complex landforms. The occurrence of large hard stones and non-soil debris can affect the agricultural potential of the restoration through interfering with/preventing cultivations and installation of underdrainage. The SRMP will have specified the need and particular requirements, within the soil replacement procedures, site conditions and after use aims.

Alternative methods to that described below can be considered. For example, there is often a preference to use agricultural tractor drawn stone rakes for the topsoil. There may be circumstances that it is economically viable to use soil screens to remove large stones and debris, particularly when the soils have been stockpiled.

Many former mineral workings have been backfilled with inert-waste. Remedial treatments of the infill, by digging or ripping, may not be advisable where these are not to be part of the replaced soil profile and this should be covered in the SRMP. The treatment of former silt-lagoons needs careful consideration and consultation with a geotechnical specialist where there is a possibility of breaking through the dewatered and stabilised upper material into the saturated underlying lower material.

MODEL METHODOLOGY

The Release & Removal Operation

L.1 The key operational points to minimise the risk of severe soil compaction and soil wetness are summarised in Boxes L.1 and L.2.

Box L.1 - To minimize compaction:

- Wherever possible the excavator and dump trucks receiving the released stones/non-soil debris are to operate on the basal layer
- The excavator with ripped claw or stone rake is only to work when soil conditions enable effective operation when the soils are in a 'dry' condition.

Box L.2

- The soil profile within the active strip should be completed to the topsoil layer before rainfall occurs and before replacement is suspended.
- Measures are required to protect the face of the soil layer from ponding of water and maintain the basal layer in a condition capable of supporting dump trucks.

L.2 The timing of soil handling operations should only take place when the soils are in a 'dry and friable' condition (ie when it breaks and shatters when disturbed rather than smears and deforms) (see **Part One, Supplementary Note 4**). Prior to the start or recommencement of soil handling they should be tested to confirm they are in suitably dry condition (see Box L.3).

L.3 Soil handling is not to take place during rain, sleet or snow and in these conditions should be prohibited due to unsafe machine operating conditions. Prior to commencing operations, a medium/long term weather forecast should be obtained which gives reasonable confidence of soil handling being completed without significant interruptions from rainfall events. The soil based criteria set out in Box L.4 are to be used to determine whether soil handling should cease or be interrupted with the occurrence of rain.

L.4 All machines must be in a safe and efficient working condition at all times. The machines are to only work when ground conditions enable safe and efficient operation. Otherwise the operation is to be suspended until suitable remedial measures can be put in place.

L.5 The operation should follow the detailed replacement plan set out in the SRMP showing soil units to be stripped, haul routes and the phasing of vehicle movements. Different soil units to be kept separate are to be marked out and information to distinguish types and layers, and ranges of thickness needs to be conveyed to the operational supervisor/operator. The haul routes and soil storage areas must be defined and should be stripped first in a similar manner. Detailed daily

Box L.3 - Test for Dry and Friable Soils

Soil tests are to be undertaken in the field. Samples shall be taken from at least five locations on the soil handling area and at each soil horizon to the full depth of the profile to be recovered/replaced. The tests shall include visual examination of the soil and physical assessment of soil consistency.

i) Examination

- If the soil is wet, films of water are visible on the surface of soil particles or aggregates (e.g. clods or peds) and/or when a clod or ped is squeezed in the hand it readily deforms into a cohesive 'ball' means **no soil handling to take place**
- If the sample is moist (i.e. there is a slight dampness when squeezed in the hand) but it does not significantly change colour (darken) on further wetting, and clods break up/crumble readily when squeezed in the hand rather than forming into a ball means **soil handling can take place**
- If the sample is dry, it looks dry and changes colour (darkens) if water is added, and it is brittle means **soil handling can take place**

ii) Consistency**First Test**

Attempt to mould soil sample into a ball by hand:

- Impossible because soil is too dry and hard or too loose and dry means soil handling can take place
- Impossible because the soil is too loose and wet means no soil handling to take place
- Possible - GO TO SECOND TEST

Second Test

Attempt to roll ball into a 3mm diameter thread by hand:

- Impossible because soil crumbles or collapses means **soil handling can take place**
- Possible means **no soil handling to take place**

NB: It is impossible to roll most coarse loamy and sandy soils into a thread even when they are wet. For these soils, the Examination Test alone is to be used.

records should be kept of operations undertaken, and site and soil conditions.

L.6 The excavator and dump trucks are to stand, work and travel on the soil or basal/formation layer according to the soil replacement practice being used (i.e. **Sheets, D, H, J & K**).

Box L.4 - Rainfall Criteria:

- In light drizzle soil handling may continue for up to four hours unless the soils are already at/near to their moisture limit
- In light rain soil handling must cease after 15 minutes
- In heavy rain and intense showers, handling shall cease immediately

In all of the above, after rain has ceased, soil tests shall be applied to determine whether handling may restart, provided that the ground is free from ponding and ground conditions are safe to do so.

L.7 The depth to which stones/damaging material can be dislodged and removed and the size of stones/materials depends on the configuration of the 'stone-rake', and the depth to which the soil/basal layer is dug in the procedure (Box L.5). For inert backfilled basal layers, the stone-rake probably can only be used when it has been decompacted first, either by an excavator with a standard bucket (see **Sheet N**) or ripping with tines (see **Sheet O**).

L.8 Where the removal of materials (wire rope, drums, tree roots, concrete lintels, etc) damaging to aftercare operations (e.g. cultivation, under-drainage installation) is not effective with the above stone-rake method, the operation is to be undertaken using digging buckets/ripper claw or tine equipment (see also **Sheets M & O**) to release the material and draw it aside for collection and disposal.

L.9 The release of stones is facilitated by the combing action of the excavator boom/tines on the stone-rake through the soil layer and to a depth required in the SRMP. For 'tines' 150-200 mm long a working depth of about 200-250 mm can be achieved.

Box L.5

There is a large range of stone-rake buckets and similar tools available for a range of stone sizes typically from 50mm to 150mm. Tine centres of less than 150mm tend to be more prone to clogging when used with clayey sub-soils, making this a practical size limit for stone removal. Where the stones to be removed from top-soils are less than 150mm, but greater than 20mm, 'finer' rakes can be used or a specialist stone picking machine. The removal of these smaller stones may only be required for certain after uses such as horticulture.



L.10 The 'radial' combing action (**Figure L.1**) is used to draw the stones towards the excavator for windrowing and loading into a dump truck for disposal or utilisation elsewhere. The radius is determined by the length of the excavator boom less the standoff to safely operate; typically, about 3-4m. Excavators with long booms ('long reach') can be used, but may be more restricted by gradient limitations, and require skilled and experienced operators.

L.11 Where the soil is a very fine texture (clayey) and has a relatively high moisture content, it can be difficult to break down soil clods and release the stones. In these circumstances the soil layer being treated may require cultivation with a bulldozer/tractor drawn heavy duty discs slightly offset from

the axis of travel.

L.12 Stone removal from the topsoil layer may be delayed until the whole area has been restored. If this option is adopted the use of the bucket method is not appropriate, and a tine cultivation method (e.g. **Sheet M**) should be used followed by removal of the stones by a specialist stone removal machine. If they are only few and large stones, these may be hand-picked and loaded into a tractor drawn trailer.

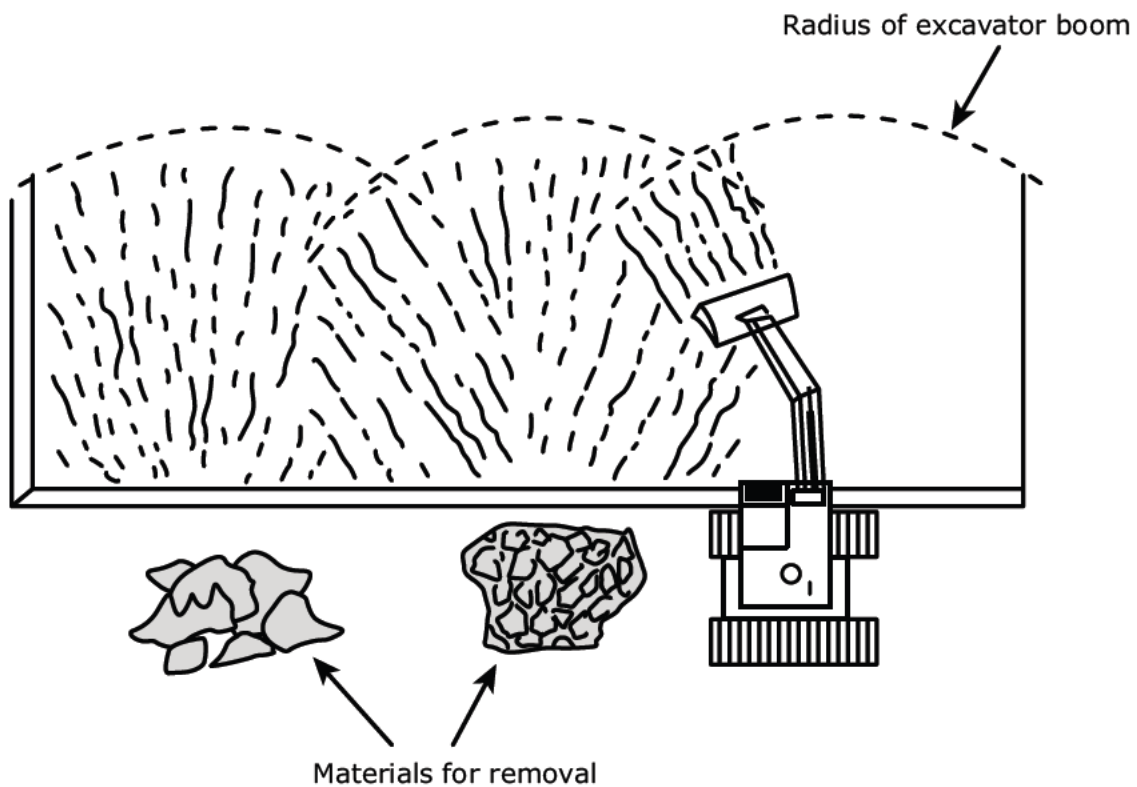

Figure L.1 Radial combing of soil surface to remove stones/damaging materials

GOOD PRACTICE GUIDE FOR HANDLING SOILS

In Mineral Workings

PART TWO: Model Methodology

- Sheet M -

Release of Stones and Non-Soil Debris
by Bulldozer Drawn Tines

Author: Dr R N Humphries CBiol CSci FRSB FBSSS FIQ
- Blakemere Consultants Ltd & Celtic Energy Ltd

Supporting artwork was provided by R Shelton (H J Banks & Co)
and D Fisher (Blue Room Graphics Ltd).

Preface

The purpose of Sheet M of the guidance is to provide a model method of best practice where bulldozer drawn tines are to be used to release stones and non-soil debris from replaced soils and the basal layer.

The guidance is intended for use by planning officials, statutory consultees, mineral operators and their supporting teams and specialist consultants, and earth-moving contractors, their site supervisors and machine operators.

Successful soil handling schemes are dependent on the soil resources being clearly identified and the conditions in which they are to be handled. This information should be contained in the Soil Resource & Management Plan (SRMP) and communicated to those involved in its implementation.

Key issues to be addressed are:

- i) Avoiding conditions when soils are wet/plastic during handling
- ii) The minimisation of soil compaction caused by trafficking and soil wetness
- iii) Using appropriate remedial treatments where these are necessary
- iv) Minimising soil loss, and mixing of soil layers or different soil types.

The SRMP should specify the type of earth-moving machinery and soil handling practice, and the soil wetness condition (see Part One of the Guidance) to be deployed to achieve the planned after use, soil functioning, and the environmental and ecosystem services. It is to be communicated in full to all involved and in particular to the supervisors and machine operators by appropriate means; including tool-box talks and site demonstrations. Supervision by trained supervisory staff is essential, as are monitoring and reporting.

The guidance does not specify the size or model of equipment as this is left to the mineral operator and contractor to specify and provide. The machines must be of a kind which are appropriate for the task and the outcomes required, and to be able to carry out the work safely and efficiently.

Should the agreed methodology need to be modified or changed significantly, this should be agreed in advance with the mineral planning authority. The SRMP should include a mechanism whereby unexpected less significant changes can be quickly resolved through consultation between the operator, the planning authority and statutory consultee, and soil specialist.

All persons involved in the handling of soils must comply with all relevant legislation with respect to Health and Safety, in particular the Health and Safety at work Act 1974 and in the case of mineral extraction operations, The Quarries Regulations 1999 and its relevant statutory provisions; in particular those aspects which relate to the construction and removal of tips, mounds and similar structures. These requirements take preference over any suggested practice in this Sheet and the SRMP should have taken these into account.

The users of this guidance are solely responsible for ensuring it complies with all safety legislation and good practice, including the manufacturer's specifications for the safe operation of the specific machines being used, and that all machines are in a good condition and well maintained and are suitable for the task. It is important that those involved in the operation of earth moving machines are competent and have the necessary training and certification.

Introduction

The purpose of this Guidance Sheet is to provide a model method for best practice where stones and/or non-soil debris (e.g. wire rope, concrete blocks) are to be released using bulldozer drawn tines from the basal layer and/or soils during replacement. The methodology can be deployed in combination with the machinery and practices presented in Sheets D, H, J and K.

Advantages & Disadvantages

The advantages are:

- i) It is an efficient means of removal of damaging materials
- ii) It is quick to deploy
- iii) It can be an effective means of decompaction (if it follows **Sheet O**).

The disadvantages are:

- i) The method requires excavators to load the collected stones/materials and to gather released stones the deployment
- ii) The need for excavators and dump trucks add another level of complexity and discipline needed in the soil replacement procedure
- iii) Ripping with tines is not an efficient means of releasing buried stones at depth (the tines tend to push them aside)
- iv) Effective release of stones from clayey soils is dependent on the soils being in a sufficiently 'dry' condition
- v) The depth of release of damaging material will be dependent on the effective length of the 'tines' (see **Sheet O**)
- vi) The size of stones dislodged is limited to the spacing of the 'tines' and pattern of ripping (see **Sheet O**)
- vii) There is a risk the removal of stones with dump trucks will result in the recompaction where trafficking the soil layers.

Suitability

The occurrence of large hard stones and non-soil debris can affect the agricultural potential of the restoration through interfering with/preventing cultivations and installation of underdrainage.

The SRMP will have specified the need and particular requirements, within the soil replacement procedures. The bulldozer drawn tines practice is the most commonly used method to release large stones/damaging materials for a wide range of after uses and ecosystem services where the content is to be reduced. It can be deployed on steep and complex landforms.

Alternative methods to that described below can be considered. For example, there is often a preference to use agricultural tractor drawn stone rakes for the topsoil. There may be circumstances that it is economically viable to use soil screens to remove large stones and debris, particularly when the soils have been stockpiled.

Many former mineral workings have been backfilled with inert waste. Remedial treatments of the infill, by digging or ripping, may not be advisable where these are not to be part of the replaced soil profile and this should be covered in the SRMP. The treatment of former silt lagoons needs careful consideration and consultation with a geotechnical specialist where there is a possibility of breaking through the dewatered and stabilised upper material into the saturated underlying lower material.

MODEL METHODOLOGY

The Release & Removal Operation

M.1 The key operational points to minimise the risk of severe soil compaction and soil wetness are summarised in Boxes M.1 and M.2.

Box M.1 - To minimize compaction:

- Wherever possible the bulldozer, excavator and dump trucks receiving the released stones/damaging material to operate on the basal layer
- The bulldozer used to release the stones/non-soil debris is only to work when soil conditions enable efficient operation
- If compaction is caused, then measures are required to treat it (see **Sheets N & O**)
- The operation should only be carried out when the soils are in a 'dry' condition.

Box M.2

- The soil profile within the active strip should be completed to the topsoil layer before rainfall occurs and before replacement is suspended
- Measures are required to protect the face of the soil layer from ponding of water and maintain the basal layer in a condition capable of supporting dump trucks.

M.2 The timing of soil handling operations should only take place when the soils are in a 'dry and friable' condition (ie when it breaks and shatters when disturbed rather than smears and deforms) (see Part One, Supplementary Note 4). Prior to the start or recommencement of soil handling they should be tested to confirm they are in suitably dry condition (see Box M.3).

M.3 Soil handling is not to take place during rain, sleet or snow and in these conditions should be prohibited due to unsafe machine operating conditions. Prior to commencing operations, a medium/long term weather forecast should be obtained which gives reasonable confidence of soil handling being completed without significant interruptions from rainfall events. The soil based criteria set out in Box M.4 are to be used to determine whether soil handling should cease or be interrupted with the occurrence of rain.

M.4 All machines must be in a safe and efficient working condition at all times. The machines are to only work when ground conditions enable safe and efficient operation. Otherwise the operation is to be suspended until suitable remedial measures can be put in place.

M.5 The operation should follow the detailed replacement plan set out in the SRMP showing soil units to be replaced, haul routes and the phasing of vehicle movements. Different soil units to be kept separate are to be marked out and information to distinguish types and layers, and ranges of thickness needs to be conveyed to the operational supervisor/operator. The haul routes

Box M.3 - Test for Dry and Friable Soils

Soil tests are to be undertaken in the field. Samples shall be taken from at least five locations on the soil handling area and at each soil horizon to the full depth of the profile to be recovered/replaced. The tests shall include visual examination of the soil and physical assessment of soil consistency.

i) Examination

- If the soil is wet, films of water are visible on the surface of soil particles or aggregates (e.g. clods or peds) and/or when a clod or ped is squeezed in the hand it readily deforms into a cohesive 'ball' means **no soil handling to take place**
- If the sample is moist (i.e. there is a slight dampness when squeezed in the hand) but it does not significantly change colour (darken) on further wetting, and clods break up/crumble readily when squeezed in the hand rather than forming into a ball means **soil handling can take place**
- If the sample is dry, it looks dry and changes colour (darkens) if water is added, and it is brittle means **soil handling can take place**

ii) Consistency**First Test**

Attempt to mould soil sample into a ball by hand:

- Impossible because soil is too dry and hard or too loose and dry means soil handling can take place
- Impossible because the soil is too loose and wet means no soil handling to take place
- Possible - GO TO SECOND TEST

Second Test

Attempt to roll ball into a 3mm diameter thread by hand:

- Impossible because soil crumbles or collapses means **soil handling can take place**
- Possible means **no soil handling to take place**

NB: It is impossible to roll most coarse loamy and sandy soils into a thread even when they are wet. For these soils, the Examination Test alone is to be used.

Box M.4 - Rainfall Criteria:

- In light drizzle soil handling may continue for up to four hours unless the soils are already at/near to their moisture limit
- In light rain soil handling must cease after 15 minutes
- In heavy rain and intense showers, handling shall cease immediately

In all of the above, after rain has ceased, soil tests shall be applied to determine whether handling may restart, provided that the ground is free from ponding and ground conditions are safe to do so.

and soil storage areas must be defined and should be stripped first in a similar manner. Detailed daily records should be kept of operations undertaken, and site and soil conditions.

M.6 The excavator and dump trucks used to collect and dispose of the material, are to stand, work and travel on the soil or basal/formation layer according to the SMP and soil replacement practice being used (i.e. **Sheets D, H, J & K**).

M.7 Ripping with bulldozer drawn tines can be used to release large stones (typically >150mm) and damaging materials (wire rope, tree roots, drums, concrete lintels etc) from the replaced soils and basal/formation layers. Where the stones to be removed are less than 150mm, but greater than 20mm, a specialist stone-rake or stone picking machine will have to be used. The use of the latter equipment is generally only applicable to the topsoil layer. The removal of these smaller stones should be part of the cultivation phase for cropping and is outside the scope of this guidance.

M.8 Where large stones and non-soil debris are damaging to aftercare operations (e.g. cultivations, underdrainage installation) they are to be removed, the equipment and practices set out here (Figure M.1) can be used and integrated into the procedures listed in **Sheets D, H, J and K**.

M.9 On completion of each soil layer or as required by the SRMP), and prior to the replacement of the

next layer the surface (as a strip/layer) available according to the handling methodology being used (see **Sheets D, H, J & K**), the area to be treated is ripped (**Figure M.1**) and where necessary with overlapping passes (**Figure O.4, Sheet O**). Generally, effective release is only achieved from the 300mm of the soil/basal layer (i.e. the height of the 'heave' above the pre-ripped ground surface caused by the ripping tool).

M.10 Bulldozers with closely spaced (0.3-0.5 m) 'stub' tines (400 mm from tip to tool bar base) are often more effective in releasing stones than deep ripping equipment designed to alleviate severe compaction at depth. Where non-soil debris is to be removed, straight legged tines without wings (see **Sheet O.2**) are the most suitable equipment; particularly in the case of basal/formation materials. Alternatively, high powered rubber-tyre tractors pulling heavy duty multi-tine cultivators can be used (depending on soil texture and moisture content).

M.11 Traditionally, large (>150 mm) stones released are collected by hand and loaded into tractor-drawn trailers travelling and standing on the soil/basal layer. Where there is a quantity of stone to be removed, the excavator with stone-rakes methodology may have to be deployed (see Sheet L) thereby, possibly negating the need of this methodology using tines.

M.12 The tines are used to release and lift non-soil debris to the surface and drag them to the edge of the strip for collection and disposal. Any equipment/machinery used for the latter is only to travel and stand on the basal/formation layer.

M.13 Where the soil is a very fine texture (clayey) and has a relatively high moisture content, it can be difficult to break down soil clods and release the stones. In these circumstances the soil layer being treated may require cultivation with a bulldozer/tractor drawn heavy duty discs slightly offset to run along the axis of travel.

M.14 Stone removal from the topsoil layer can be delayed until the whole area has been restored. A shallower ripping (300mm) and/or discing with heavy duty disc cultivators of the topsoil will be needed to

release the stone followed by removal of the stones by a specialist stone removal machine. If they are only few and large stones, these may be hand-picked and loaded into a tractor drawn trailer. If this option is adopted, trafficking of the topsoil layer will take place during the collection of the stones and remedial treatment of the recompaction will be required.

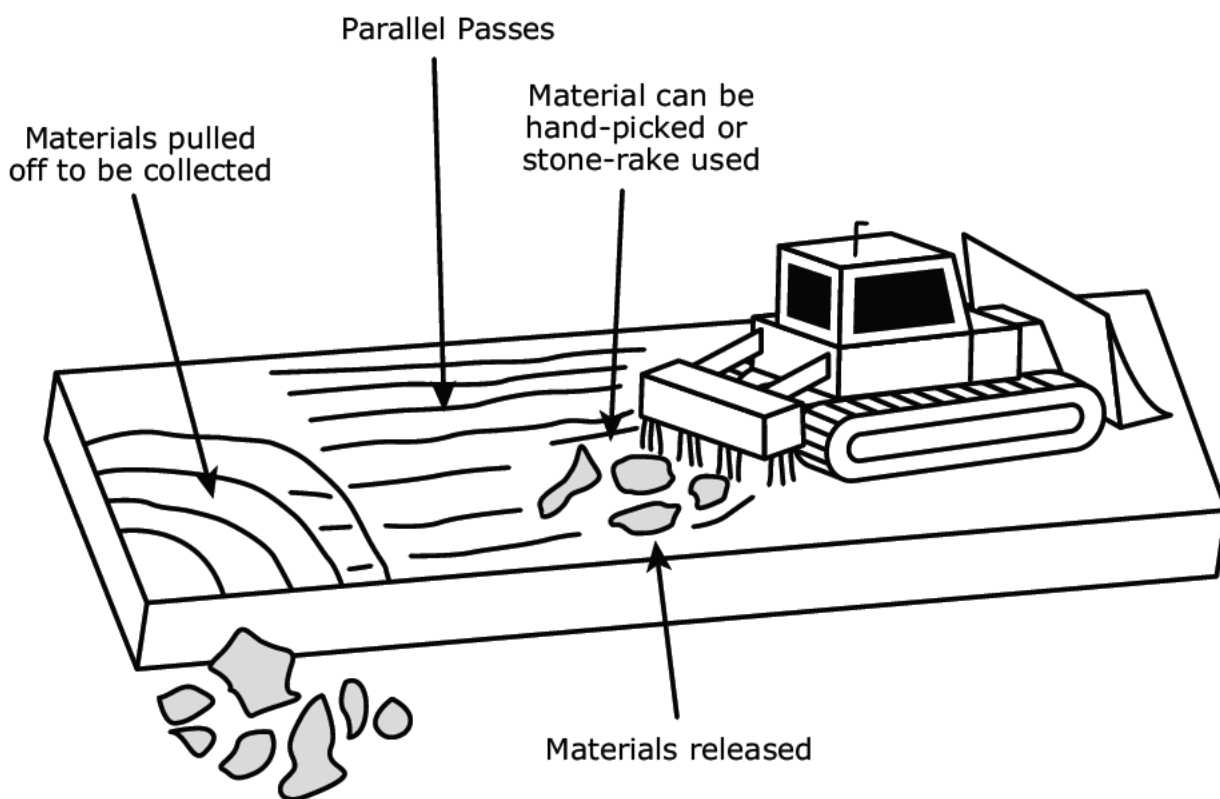

Figure M.1 Ripping with tines to release large stones and damaging materials.

GOOD PRACTICE GUIDE FOR HANDLING SOILS

In Mineral Workings

PART TWO: Model Methodology

- Sheet N -

Soil Decomaction by Excavator Bucket

Author: Dr R N Humphries CBiol CSci FRSB FBSSS FIQ
- Blakemere Consultants Ltd & Celtic Energy Ltd

Supporting artwork was provided by R Shelton (H J Banks & Co)
and D Fisher (Blue Room Graphics Ltd).

Preface

The purpose of Sheet N of the guidance is to provide a model method of best practice where excavators are to be used to decompact replaced soils and the basal layer by digging with a bucket.

The guidance is intended for use by planning officials, statutory consultees, mineral operators and their supporting teams and specialist consultants, and earth-moving contractors, their site supervisors and machine operators.

Successful soil handling schemes are dependent on the soil resources being clearly identified and the conditions in which they are to be handled. This information should be contained in the Soil Resource & Management Plan (SRMP) and communicated to those involved in its implementation.

Key issues to be addressed are:

- i) Avoiding conditions when soils are wet/plastic during handling
- ii) The minimisation of soil compaction caused by trafficking and soil wetness
- iii) Using appropriate remedial treatments where these are necessary
- iv) Minimising soil loss, and mixing of soil layers or different soil types.

The SRMP should specify the type of earth-moving machinery and soil handling practice, and the soil wetness condition (see Part One of the Guidance) to be deployed to achieve the planned after use, soil functioning, and the environmental and ecosystem services. It is to be communicated in full to all involved and in particular to the supervisors and machine operators by appropriate means; including tool-box talks and site demonstrations. Supervision by trained supervisory staff is essential, as are monitoring and reporting.

The guidance does not specify the size or model of equipment as this is left to the mineral operator and contractor to specify and provide. The machines must be of a kind which are appropriate for the task and the outcomes required, and to be able to carry out the work safely and efficiently.

Should the agreed methodology need to be modified or changed significantly, this should be agreed in advance with the mineral planning authority. The SRMP should include a mechanism whereby unexpected less significant changes can be quickly resolved through consultation between the operator, the planning authority and statutory consultee, and soil specialist.

All persons involved in the handling of soils must comply with all relevant legislation with respect to Health and Safety, in particular the Health and Safety at work Act 1974 and in the case of mineral extraction operations, The Quarries Regulations 1999 and its relevant statutory provisions; in particular those aspects which relate to the construction and removal of tips, mounds and similar structures. These requirements take preference over any suggested practice in this Sheet and the SRMP should have taken these into account.

The users of this guidance are solely responsible for ensuring it complies with all safety legislation and good practice, including the manufacturer's specifications for the safe operation of the specific machines being used, and that all machines are in a good condition and well maintained and are suitable for the task. It is important that those involved in the operation of earth moving machines are competent and have the necessary training and certification.

Introduction

The purpose of this Guidance Sheet is to provide a model method for best practice where an excavator is used to decompact soils and basal/formation layers. Excavators are most likely to be used for this purpose where soils are replaced by excavator (Sheet D), however the methodology can be deployed in combination with the machinery and practices presented in Sheets H, J and K.

Advantages & Disadvantages

The advantages of the methodology are:

- i) It is an efficient means of decompaction
- ii) The equipment is standardized and readily available
- iii) It is flexible with the quick interchange with a stone-rake for the need remove stones or level/cultivate a final surface
- iv) It is suited to single shallow soil layer.

The disadvantages are:

- i) The deployment adds another level of complexity needed in the soil replacement and skill and discipline in the decompaction procedures
- ii) The methodology is significantly slower than the alternative of ripping (**Sheet S**)
- iii) The effective decompaction is dependent on the soils being in a sufficiently 'dry' condition
- iv) There is a risk of mixing of soil horizons.

Suitability

This practice is the most suitable for a wide range of and uses, soil functions, and environmental and ecosystem services where decompaction is required. It can be deployed on steep and complex landforms. Like with the use of tines (**Sheet O**), to be effective the soil must be dry enough to shatter. The SRMP will have specified the need and particular requirements, within the soil replacement procedures, site conditions land and use aims.

Many former mineral workings have been backfilled with inert waste. Remedial treatments of the infill, by digging or ripping, may not be advisable where these are not to be part of the replaced soil profile and this should be covered in the SRMP. The

treatment of former silt lagoons needs careful consideration and consultation with a geotechnical specialist where there is a possibility of breaking through the dewatered and stabilised upper material into the saturated underlying lower material.

MODEL METHODOLOGY

The Decompaction Operation

N.1 Key operational points to minimize the risk of severe soil compaction and soil wetness are summarised in Boxes N.1 and N.2.

Box N.1 - To minimize compaction:

- Wherever possible the excavator is to operate on the basal layer
- The excavator is only to work when ground conditions enable efficient operation
- The operation should only be carried out when the soils are in a 'dry' condition.

Box N.2

- The soil profile within the active strip should be completed to the topsoil layer before rainfall occurs and before replacement is suspended
- Measures are required to protect the face of the soil layer from ponding of water and maintain the basal layer in a condition capable of supporting dump trucks.

N.2 The timing of soil handling operations should only take place when the soils are in a 'dry and friable' condition (i.e. when it breaks and shatters when disturbed rather than smears and deforms) (see **Part One, Supplementary Note 3**). Prior to the start or recommencement of soil handling they should be tested to confirm they are in suitably dry condition (see Box N.3).

N.3 Soil handling is not to take place during rain, sleet or snow and in these conditions should be prohibited due to unsafe machine operating conditions. Prior to commencing operations, a medium/long term weather forecast should be obtained which gives reasonable confidence of soil handling being completed without significant interruptions from rainfall events. The soil based

Box N.3 - Test for Dry and Friable Soils

Soil tests are to be undertaken in the field. Samples shall be taken from at least five locations on the soil handling area and at each soil horizon to the full depth of the profile to be recovered/replaced. The tests shall include visual examination of the soil and physical assessment of soil consistency.

i) Examination

- If the soil is wet, films of water are visible on the surface of soil particles or aggregates (e.g. clods or peds) and/or when a clod or ped is squeezed in the hand it readily deforms into a cohesive 'ball' means **no soil handling to take place**
- If the sample is moist (i.e. there is a slight dampness when squeezed in the hand) but it does not significantly change colour (darken) on further wetting, and clods break up/crumble readily when squeezed in the hand rather than forming into a ball means **soil handling can take place**
- If the sample is dry, it looks dry and changes colour (darkens) if water is added, and it is brittle means **soil handling can take place**

ii) Consistency**First Test**

Attempt to mould soil sample into a ball by hand:

- Impossible because soil is too dry and hard or too loose and dry means soil handling can take place
- Impossible because the soil is too loose and wet means no soil handling to take place
- Possible - GO TO SECOND TEST

Second Test

Attempt to roll ball into a 3mm diameter thread by hand:

- Impossible because soil crumbles or collapses means **soil handling can take place**
- Possible means **no soil handling to take place**

NB: It is impossible to roll most coarse loamy and sandy soils into a thread even when they are wet. For these soils, the Examination Test alone is to be used.

criteria set out in BOX N.4 are to be used to determine whether soil handling should cease or be interrupted with the occurrence of rain.

N.3 Soil handling is not to take place during rain, sleet or snow and in these conditions should be prohibited due to unsafe machine operating conditions. Prior to commencing operations, a medium/long term weather forecast should be obtained which gives reasonable confidence of soil handling being completed without significant interruptions from rainfall events. The soil based criteria set out in Box N.4 are to be used to determine whether soil handling should cease or be interrupted with the occurrence of rain.

Box N.4 - Rainfall Criteria:

- In light drizzle soil handling may continue for up to four hours unless the soils are already at/ near to their moisture limit
- In light rain soil handling must cease after 15 minutes
- In heavy rain and intense showers, handling shall cease immediately

In all of the above, after rain has ceased, soil tests shall be applied to determine whether handling may restart, provided that the ground is free from ponding and ground conditions are safe to do so.

N.4 All machines must be in a safe and efficient working condition at all times. The machines are to only work when ground conditions enable safe and efficient operation. Otherwise the operation is to be suspended until suitable remedial measures can be put in place.

N.5 The operation should follow the detailed replacement plan set out in the SRMP showing soil units to be stripped, haul routes and the phasing of vehicle movements. Different soil units to be kept separate are to be marked out and information to distinguish types and layers, and ranges of thickness needs to be conveyed to the operational supervisor/operator. The haul routes and soil storage areas must be defined and should be stripped first in a similar manner. Detailed daily records should be kept of operations undertaken, and site and soil conditions.

N.6 The digging radius is determined by excavator boom length less the stand-off to operate; typically, about 3-4m. Excavators with long booms ('long reach') can be used, but may be more restricted by gradient limitations, and require skilled and experienced operators. The excavator bucket is to be maximum capacity of 2.5m³ and 1.0 m to 1.5m wide cutting edge (blade) with armoured teeth at about 150 mm spacing, 150 mm long and 50mm in section.

N.7 The excavator should stand on and work from the basal/formation layer wherever possible.

N.8 Where the soil layer to be decompacted as a single layer and is less than about 0.5m thick the following procedure is to be adopted. The area to be treated is decompacted as a series of sequential 'trenches' to the depth required (**Figure N.1**).

N.9 Each trench is to be the effective working length of the excavator boom (nominally 3-4m). The trench is started by inserting the bucket 'blade' downwards into the soil to the depth required and keeping this vertical attitude pulled towards the excavator (**Figure N.1**). When the bucket is almost filled it is lifted and the soil tipped into the 'trench' created. The bucket's tines have a ripping action and the pushing of the soil into the bucket has a shattering effect if the soil is dry enough, otherwise it will compress the soil material with no resulting beneficial effect. If the replaced soil in the trench is cloddy, it can be 'chopped' using the bucket's blade. The process is repeated until the trench has been decompacted, then another trench is treated until the whole area to be treated is completed. It is essential each successive bucket 'dig' overlaps with the former both to the back and sides of the trenches. Finally, the bucket cutting edge can be used to lightly grade the finished surface.

N.10 Where the soil layer is deeper than the capability of the bucket (about 0.5m), a 'double-digging' approach is needed. The process is similar to above, but the upper material in the trench is to be cast aside over the adjacent untreated strip ('double digging'). The exposed lower layer is then treated as above and on completion the cast aside upper material is replaced with any necessary

cultivation/levelling with the bucket taking place. This method is relatively slow.

N.11 The alternative for deep profiles than 0.5m to be decompacted by the excavator method is to place the soil layer in several successive sub-layers each up to 0.5m in thickness, and to sequentially decompact each replaced layer as described above. The process is repeated until the full soil horizon is replaced to the required thickness and has been completely 'dug over'. This method is also slow.

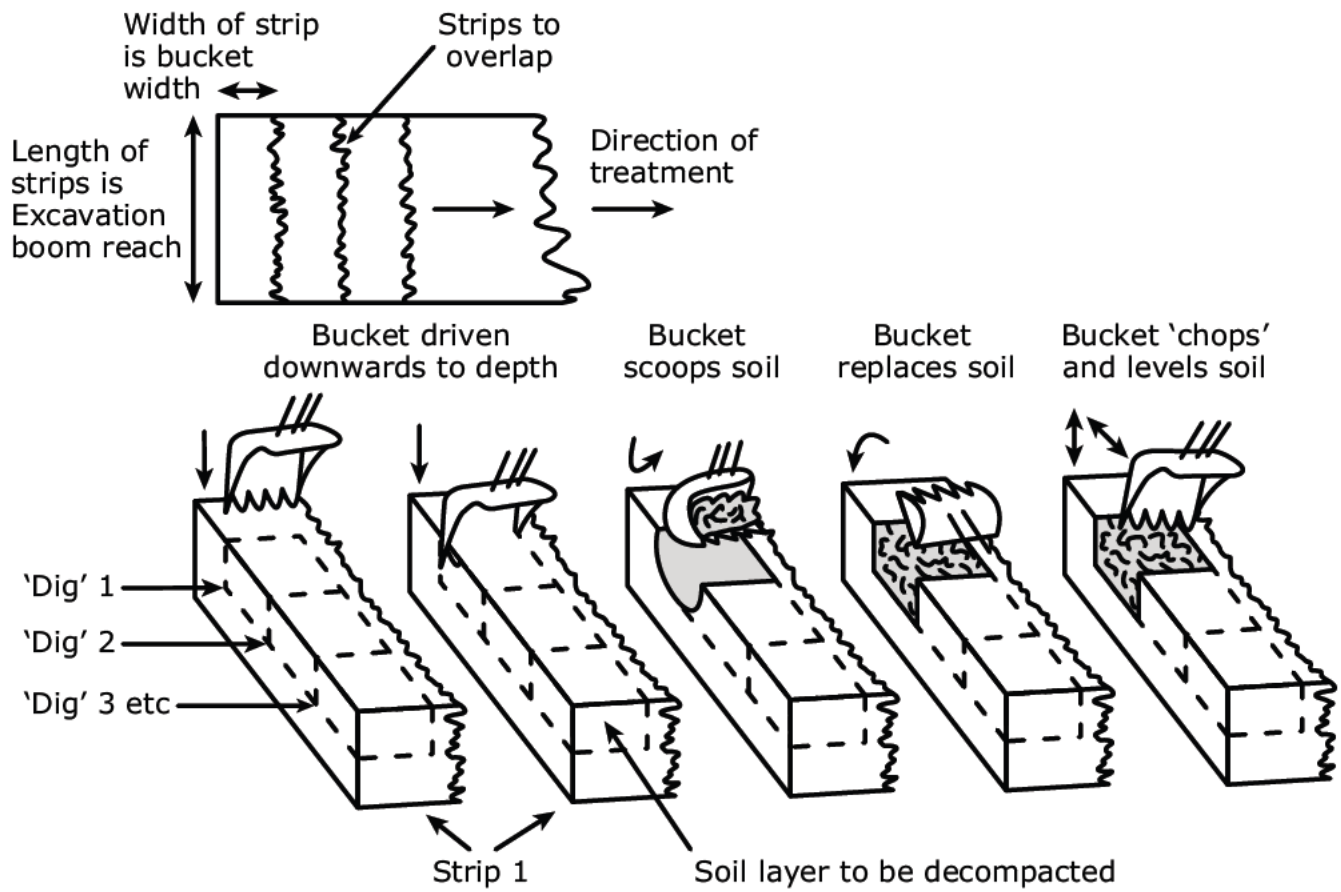

Figure N.1 Decompaction by excavator bucket..

GOOD PRACTICE GUIDE FOR HANDLING SOILS

In Mineral Workings

PART TWO: Model Methodology

- Sheet O -

Soil Decompaction by
Bulldozer Drawn Tines

Author: Dr R N Humphries CBiol CSci FRSB FBSS FIQ
- Blakemere Consultants Ltd & Celtic Energy Ltd

Supporting artwork was provided by R Shelton (H J Banks & Co)
and D Fisher (Blue Room Graphics Ltd).

Preface

The purpose of Sheet O of the guidance is to provide a model method of best practice where bulldozer drawn tines are to be used to decompact soils.

The guidance is intended for use by planning officials, statutory consultees, mineral operators and their supporting teams and specialist consultants, and earth-moving contractors, their site supervisors and machine operators.

Successful soil handling schemes are dependent on the soil resources being clearly identified and the conditions in which they are to be handled. This information should be contained in the Soil Resource & Management Plan (SRMP) and communicated to those involved in its implementation.

Key issues to be addressed are:

- i) Avoiding conditions when soils are wet/ plastic during handling
- ii) The minimisation of soil compaction caused by trafficking and soil wetness
- iii) Using appropriate remedial treatments where these are necessary
- iv) Minimising soil loss, and mixing of soil layers or different soil types.

The SRMP should specify the type of earth-moving machinery and soil handling practice, and the soil wetness condition (see Part One of the Guidance) to be deployed to achieve the planned after use, soil functioning, and the environmental and ecosystem services. It is to be communicated in full to all involved and in particular to the supervisors and machine operators by appropriate means; including tool-box talks and site demonstrations. Supervision by trained supervisory staff is essential, as are monitoring and reporting.

The guidance does not specify the size or model of equipment as this is left to the mineral operator and contractor to specify and provide. The machines must be of a kind which are appropriate for the task and the outcomes required, and to be able to carry out the work safely and efficiently.

Should the agreed methodology need to be modified or changed significantly, this should be agreed in advance with the mineral planning authority. The SRMP should include a mechanism whereby unexpected less significant changes can be quickly resolved through consultation between the operator, the planning authority and statutory consultee, and soil specialist.

All persons involved in the handling of soils must comply with all relevant legislation with respect to Health and Safety, in particular the Health and Safety at work Act 1974 and in the case of mineral extraction operations, The Quarries Regulations 1999 and its relevant statutory provisions; in particular those aspects which relate to the construction and removal of tips, mounds and similar structures. These requirements take preference over any suggested practice in this Sheet and the SRMP should have taken these into account.

The users of this guidance are solely responsible for ensuring it complies with all safety legislation and good practice, including the manufacturer's specifications for the safe operation of the specific machines being used, and that all machines are in a good condition and well maintained and are suitable for the task. It is important that those involved in the operation of earth moving machines are competent and have the necessary training and certification.

Introduction

The purpose of this Guidance Sheet is to provide a model method for best practice where bulldozer drawn tines are used to decompact soils and basal/formation layers. Tines are most likely to be used for this purpose where soils are replaced by bulldozers and dump truck combinations (Sheets H, J & K), however, the methodology can be deployed in the excavator machinery combinations and practices presented (Sheet D).

Advantages & Disadvantages

The advantages of the methodology are:

- i) The practice is relatively simple to deploy when there are suitable ripping tools and experience in their proper use
- ii) The procedure is relatively quick to administer
- iii) Significant mixing of soil horizons can be minimized
- iv) It can be deployed on steep and complex landforms.

The disadvantages are:

- i) The deployment adds another level of complexity needed in the soil replacement and skill and discipline in the decompaction procedures
- ii) Whilst there is wide familiarity with the technique, there is little understanding of its limitations
- iii) Adequate ripping tools in a good condition can be difficult to locate
- iv) The method is sensitive to soil being too wet (plastic)

Suitability

Where conditions are suitable, the practice can be deployed for a wide range of after uses, soil functions, and environmental and ecosystem services, where decompaction is required. Like with the use of excavators (**Sheet N**), to be effective the soil must be dry enough to shatter. The SRMP will have specified the need and particular requirements, within the particular soil replacement procedures, site conditions and land use aims.

Many former mineral workings have been backfilled with inert waste. Remedial treatments of the infill, by digging or ripping, may not be advisable where these are not to be part of the replaced soil profile and this should be covered in the SRMP. The treatment of former silt lagoons needs careful consideration and consultation with a geotechnical specialist where there is a possibility of breaking through the dewatered and stabilised upper material into the saturated underlying lower material.

MODEL METHODOLOGY

The Decompaction Operation

O.1 Key operational points to minimize the risk of severe soil compaction and soil wetness are summarised in Boxes O.1 and O.2.

Box O.1 - To maximize the effectiveness of decompaction treatments:

- The moisture content of the soils should be at least 5% below their plastic limit, or greater if so advised
- The ripping pattern must be overlapping parallel passes and recompaction at depth must be treated in the ripping strategy
- The tines should be sufficiently closely spaced to ensure that full lateral decompaction is achieved with overlapping passes
- The use of winged straight tines is recommended
- the tine length and width must be compatible with the proposed depth of decompaction and allow for soil 'heave'
- Tine and wings must have wear plates and be in good operating condition. Worn and deformed tools must not be used
- The towing unit must be capable of pulling the tine combination in an operationally efficient manner, without undue weaving and track slippage.

O.2 The timing of soil handling operations should only take place when the soils are in a 'dry and friable' condition (ie when it breaks and shatters when disturbed rather than smears and deforms) (see **Part One, Supplementary Notes 3 & 4**).

Box O.2 - To minimize re-wetting:

- The ripping should not be undertaken if significant rainfall is forecast
- Where the soil profile is partly raised to ground level, the uppermost soil layer should be left in an unripped state. Where the subsoil layer has been ripped, but the topsoil not placed, it should be sealed by blading with a bulldozer. On resumption of operations, the upper and lower layers will require decompacting

Prior to the start or recommencement of soil handling they should be tested to confirm they are in suitably dry condition (see Box O.3).

O.3 Soil handling is not to take place during rain, sleet or snow and in these conditions should be prohibited due to unsafe machine operating conditions. Prior to commencing operations, a medium/long term weather forecast should be obtained which gives reasonable confidence of soil handling being completed without significant interruptions from rainfall events. The soil based criteria set out in BOX O.4 are to be used to determine whether soil handling should cease or be interrupted with the occurrence of rain.

O.4 All machines must be in a safe and efficient working condition at all times. The machines are to only work when ground conditions enable safe and efficient operation. Otherwise the operation is to be suspended until suitable remedial measures can be put in place.

O.5 The operation should follow the detailed replacement plan set out in the SRMP showing soil units to be stripped, haul routes and the phasing of vehicle movements. Different soil units to be kept separate are to be marked out and information to distinguish types and layers, and ranges of thickness needs to be conveyed to the operational supervisor/operator. The haul routes and soil storage areas must be defined and should be stripped first in a similar manner. Detailed daily records should be kept of operations undertaken, and site and soil conditions.

Box O.3 - Test for Dry and Friable Soils

Soil tests are to be undertaken in the field. Samples shall be taken from at least five locations on the soil handling area and at each soil horizon to the full depth of the profile to be recovered/replaced. The tests shall include visual examination of the soil and physical assessment of soil consistency.

i) Examination

- If the soil is wet, films of water are visible on the surface of soil particles or aggregates (e.g. clods or peds) and/or when a clod or ped is squeezed in the hand it readily deforms into a cohesive 'ball' means **no soil handling to take place**
- If the sample is moist (i.e. there is a slight dampness when squeezed in the hand) but it does not significantly change colour (darken) on further wetting, and clods break up/crumble readily when squeezed in the hand rather than forming into a ball means **soil handling can take place**
- If the sample is dry, it looks dry and changes colour (darkens) if water is added, and it is brittle means **soil handling can take place**

ii) Consistency**First Test**

Attempt to mould soil sample into a ball by hand:

- Impossible because soil is too dry and hard or too loose and dry means soil handling can take place
- Impossible because the soil is too loose and wet means no soil handling to take place
- Possible - GO TO SECOND TEST

Second Test

Attempt to roll ball into a 3mm diameter thread by hand:

- Impossible because soil crumbles or collapses means **soil handling can take place**
- Possible means **no soil handling to take place**

NB: It is impossible to roll most coarse loamy and sandy soils into a thread even when they are wet. For these soils, the Examination Test alone is to be used.

Box O.4 - Rainfall Criteria:

- In light drizzle soil handling may continue for up to four hours unless the soils are already at/near to their moisture limit
- In light rain soil handling must cease after 15 minutes
- In heavy rain and intense showers, handling shall cease immediately

In all of the above, after rain has ceased, soil tests shall be applied to determine whether handling may restart, provided that the ground is free from ponding and ground conditions are safe to do so.

Ripping Strategies

O.6 Ripping to decompact soils is a necessary part of the soil replacement procedures using bulldozer-dump truck combinations. The primary aim of the ripping strategy is to ensure that there is no significant compaction within the soil profile which might impede root growth or drainage. There are two basic ripping strategies that can be used:

- When the soil profile is ripped sequentially as the soil layers are built up; and
- When it is ripped only after the full profile is complete.

O.7 Sequential ripping of each layer before next is placed has to be carried out during the replacement operations (**Figure O.1a**). The ripping of the final surface layer can be delayed until all the topsoil layer has been replaced. It is appropriate when:

- The soil profile/horizon thickness exceeds the effective depth of the tine or capacity of the towing unit being used; a number of sequential rips are required, each layer ripped before the next is placed
- The depth of subsequent sequential ripping must relieve any recompaction of the lower layers following the placement of the new overlying layer or other surface operations
- Stones and/or damaging materials are to be released and removed from sub-surface horizons.

O.8 Single deep ripping on completion of profile (**Figure O.1b**): It is appropriate when:

- The profile thickness is equivalent to or less than the effective depth of tine and capabilities of towing unit
- Large stones and/or non-soil debris are absent or need not be removed from sub-surface horizons
- Debris or stones need only to be removed from surface topsoil layer, where a shallower surface cultivation would be carried out prior to final ripping
- Sequential ripping has been undertaken and there is still recompaction at depth
- Final ripping can be delayed until all strips and final works complete, or later in aftercare period.

O.9 Both strategies have their limitations and the selection should be compatible with the land use, soil function, environmental and ecosystem services objectives, the soil profile in question and the capability of the equipment to be used. It may not be possible to treat deep compaction or even compaction at moderate depth once the profile has been completed. Hence, it is essential that the correct strategy is adopted. In some circumstances it may be necessary to adopt a combination of both strategies to achieve satisfactory results.

Equipment

O.10 Bulldozer units of a minimum 300hp are usually required to be able to carry out the operations effectively (Box O.5).

O.11 There are two types of ripping units:

- Frame-mounted on a bulldozer unit and often hydraulic operated
- Mounted on towed trailers/tool carriers and either cable or hydraulic operated.

Control mechanisms have to be compatible between the bulldozer unit and tool carriers

Box O.5

Approximately 30hp/leg or shank on multiple tine beam cultivator to 750mm depth and 100hp/tine three leg or shank to 750mm depth.

O.12 There are two types of tines: straight leg and curved leg. The former is the most commonly used and is the principal tool for decompaction. Straight tines are to be used where there are obstructions, or the soils/formation layer is excessively stony. Curved tines are typically used, in combination with straight tines, and set to operate at shallower depth for the purpose of reducing the 'drag' resistance of the following straight tines. Often the straight tine is operated in a raked mode (about 10 degrees forwards) rather than in an upright stance to promote decompaction by creating uplift and also to reduce drag.

O.13 Straight tines (leg) should have a wedge foot (**Figure O.2**) at the base to reduce drag, aid penetration and assist with the upward displacement of the soil and shattering effect.

O.14 There are two forms of straight tines: those with and those without wings (**Figure O.2**). Wings of 250-400mm total span (outer tip to outer tip) are welded either side of the tine leg or foot at angle 20-30 degrees. This is to promote upward displacement and lateral shatter, but also has the effect of significantly increasing drag. Straight tines without wings will require either more overlapping passes or closer spaced tines (the closer spacing will increase drag).

O.15 There are two critical dimensions which determine the potential effectiveness of the tines and hence the ripping operation are: i) Tine length (which determines the potential depth of decompaction); ii) Tine thickness (which determines the potential amount of heave and therefore shatter and decompaction). The achievement of the potential of the ripping tools is dependent on the moisture content of the soil/formation material (it must be dry enough to shatter otherwise the soil material simply deforms around the tool).

O.16 The length of the tine is the most common limiting dimension of the tool. The length of the tine from the heel of the foot to the base of the tool bar/carrier less 200/250mm or 30%, whichever is the lesser, is the potential maximum effective ripping depth of the tine (**Figure O.3**). This is to allow for upward displacement of the soil as the tool is drawn

through the profile. Without this allowance the soil heave will rise to or above the tool bar and increase drag and reduce the decompaction achieved (**Figure O.3**), cause compaction, overheat the bulldozer hydraulics etc.

O.17 The most commonly used tines of between 300-700mm below the tool bar have maximum effective depths of about 150-500mm (Box O.6).

O.18 Longer tines can be provided but these may cause problems with mobility of the bulldozer unit. One exception is the British Coal specification SIMBA MK IV Ripper with 1.2m carrier borne tines which has a potential effective depth of 900mm.

O.19 The width of the tine (front to back) co-determines the potential effective ripping/decompaction depth, with a ratio of 5 times the width of the tine (**Figure O.2**). Typically, the width of the tine is 300-400mm, giving a potential effective depth of 1500-2000mm, which operationally is not usually the limiting factor. The thickness and width of the tine used is usually determined by other factors, the mechanical stresses imposed by the work undertaken (i.e. its strength) and the slot dimensions in the tool bar carrier.

Box O.6 - Allowance for Soil Heave

Length of tine below tool bar mm	Potential maximum effective length mm
200	100
300	150
400	200
500	300
600	400
700	500

O.20 The thickness of the tine (typically 40-80mm) contributes significantly to its strength but also to its drag. The tine should have a welded wear plate on the leading edge to reduce wear, as should the

leading edge of the attached wings (**Figure O.2**).

O.21 The minimum number of tines must be two, each following the mid-point of the tracks of the bulldozer unit (**Figure O.4**). Generally, the most common configuration is three with a tine central to the bulldozer unit. The tines may be arranged in a straight line or as a triangle where the central tine is set further forward to reduce drag. The tines may or may not have wings, often the central tine may be without wings to reduce drag. Three winged tines are likely to be required where only single passes are made. Straight tines without wings are often more appropriate where there are significant damaging obstructions and where soils are excessively stony.

O.22 Mixed combinations of curved tines leading straight tines (as a double beam configuration) are an alternative and can potentially achieve more effective lateral shatter.

Decompaction Operations

O.23 Ripping to decompact materials must only to be undertaken when the soils are dry enough to shatter (i.e. not in a plastic condition) and must be suspended before the soil become plastic. Ripping should only be undertaken in dry weather and is to be suspended when the tractor unit loses traction/ weaves under normal operating conditions. If the soils are inherently wet consideration should be given to deep ripping later following the establishment of a crop to dry out the upper horizons; this may require several successive years of treatment to progressively decompact the profile.

O.24 The tines are to be drawn through the basal/formation or soil layer at the required depth according to the decompaction strategy and capability of the bulldozer and towed/fixed equipment. The tines are to be drawn at sufficient and constant speed, and at their optimum angle (rake) to achieve maximum heave with the least drag, and without track slippage or the bulldozer unit 'weaving'.

O.25 The ripping is only to be undertaken along one axis and usually at an orientation to promote down-slope drainage (see Box O.7), but never crosswise

or across slope unless it is specifically in the SRMP to retain water (as is the practice in dry climates). When ripping is down slope on steep gradients, the machinery is to travel back only on unripped ground.

O.26 The ripping must achieve the required depth in the first pass without the heave rising above the base of the tool bar (Figure O.3), the tine is to enter to its full depth on the first pass and all subsequent passes. The area should not be ripped to a shallow depth first and then re-ripped to a greater depth. However, in some cases and on the basal layer this may be unavoidable in the first pass in order to 'break' ground and reduce resistance to be able to achieve the required penetration. Headlands are to be ripped first to enable quick and full penetration of the tines; this is essential at the base of slopes. Ripping must extend into and out of the sides of existing ditches or if installed later the ditches are to be cut across the lower rip-lines.

Box O.7 – Subsoil 'Piping' Caused by Ripping

Particularly with sandy soils, ripping up/down slope can facilitate the creation of subsurface 'pipes' through the preferential drainage. These can lead to 'soil busts' in wet weather and local collapses/washouts. To minimize this, either cross slope grips or drains can be installed.

O.27 Where the final profile thickness is equivalent to or less than the effective depth of the tine, the ripping operation can be undertaken after all the horizon(s) have been laid (**Figure O.1b**), except where it is necessary for stones or non-soil debris to be removed.

O.28 Where the profile thickness exceeds the effective depth of the tine, the profile must be ripped in a sequence of successive layers. The ripping is to be undertaken sequentially following the placement of each layer and before the next layer can be laid. This usually takes place after the placement of each horizon (ie lower subsoil, upper subsoil and topsoil) (**Figure O.1b**). If the proposed horizon thickness exceeds the effective depth of the ripper tine, then the soil horizon needs to be laid in sub-layers, with

each of these being ripped to the required depth before the next is laid.

O.29 In the ripping of successive replaced horizons/layers, allowance must be given to recompaction caused in the lower layers by the laying and spreading of the soil by bulldozers, and dump trucks transporting stones and damaging materials for disposal. The allowance necessary depends on the soil type and moisture content. For dump trucks, bulldozers with narrow tracks and large excavators, recompaction to 400-600mm should be allowed for in specifying the thickness of the next layer of soil to be placed and its decompaction. A minimum of 300mm should be allowed for bulldozers with standard tracks and as a precaution the same for wide tracked machines. The recompacted soil layer must be decompacted along with the thickness of the new layer laid. This requires the depth of decompaction of the next layer to include the thickness of the recompacted soil layers. The thickness of the new layer that can be laid over the recompacted layer(s) will be governed by the potential effective depth of the tine. Hence, after the laying and decompaction of the first soil layer, subsequent soil layers will have to be laid at shallower thickness (**Figure O.3**).

O.30 The final decompaction of the topsoil layer should be to the full effective depth of the tine.

O.31 In carrying out the ripping operation, each successive pass is to overlap, with the tine on the ripped side bisecting the pass of the outer and central tine of the previous pass (**Figure O.4**). Where full depth or lateral consistency of decompaction is not achieved, the overlap should be increased.

O.32 The degree and consistency of loosened soil must be checked as the ripping is taking place, especially across the junctions between laid strips of soil (which may require inspection by pits). Routine qualitative assessment can be made with a 15mm diameter steel probe with a blunt convex end.

O.33 The probe is pressed in soils at 150mm intervals along a number of transects across the line of ripping, and the depth to penetration and feel

of resistance recorded (**Figure O.5**). Alternatively, more sophisticated (recording) soil penetrometers may be used. Both methods should only be used in conjunction with a method of on-site 'calibration' of compactness; this is essential as soil water content and stoniness have a major influence on interpretation.

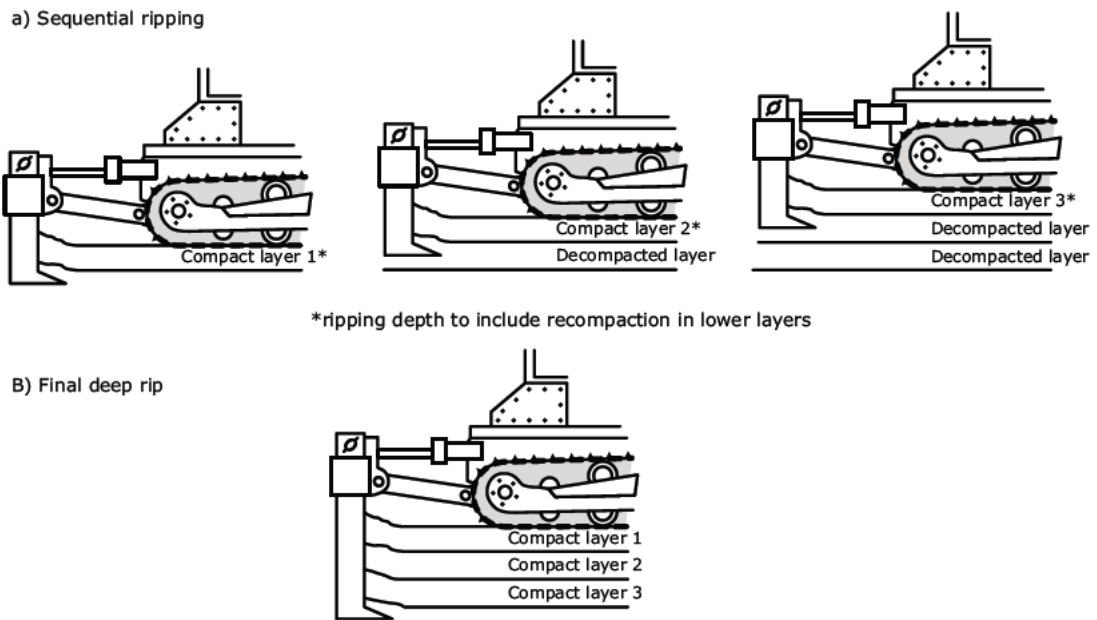

Figure O.1: Decompaction by bulldozer drawn tines.

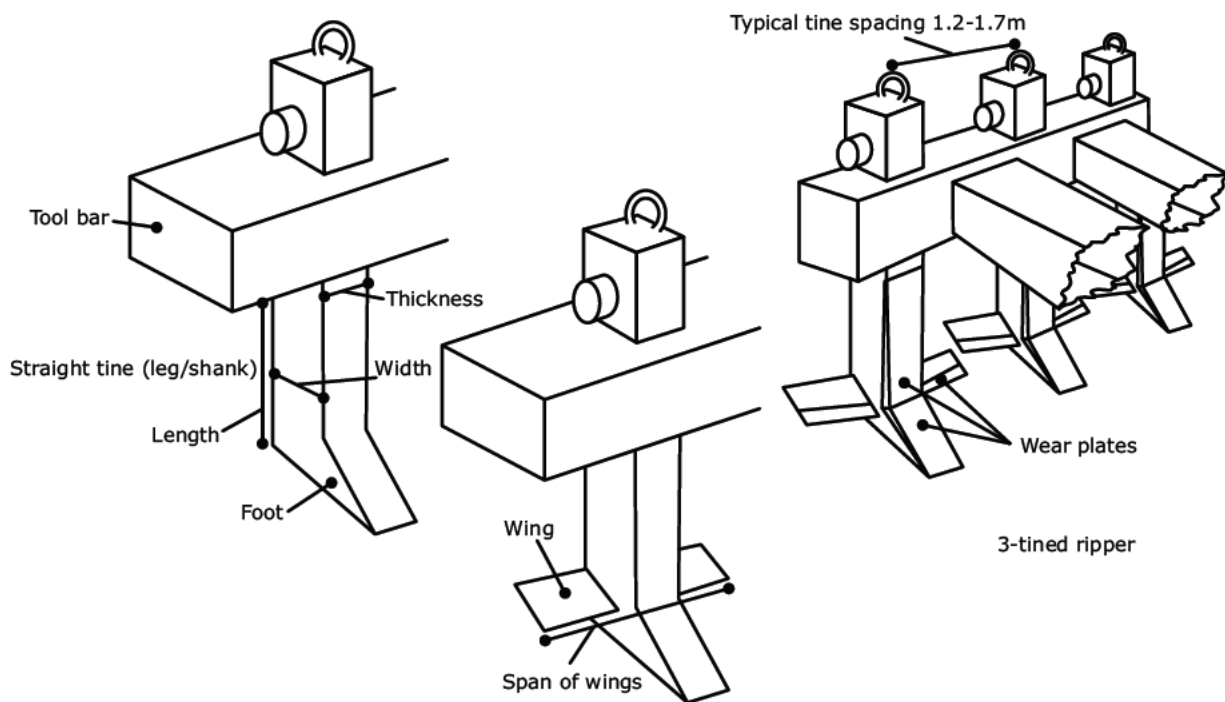
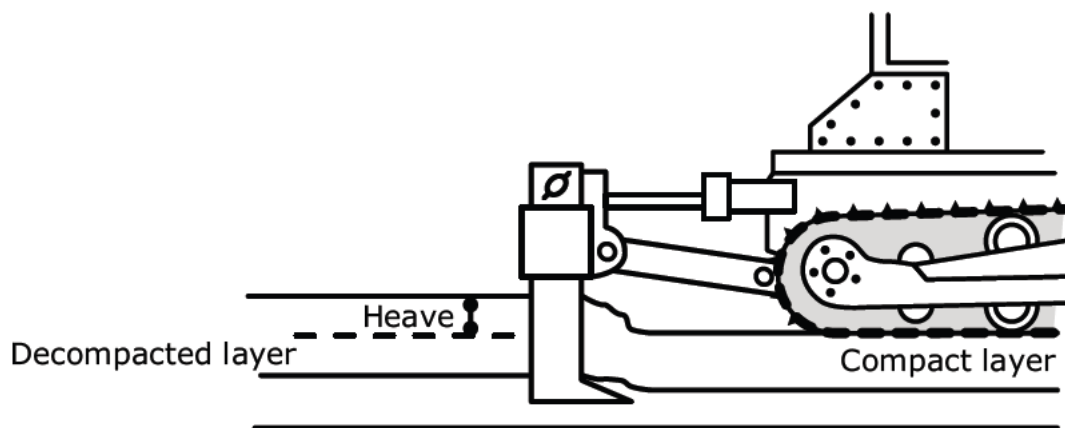
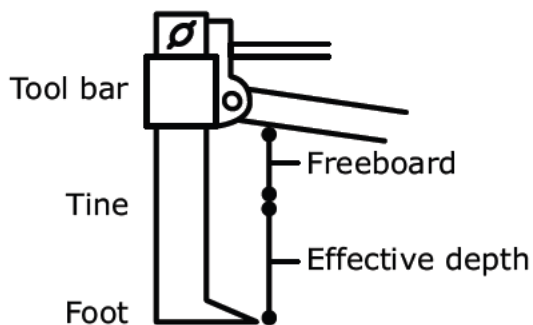

Figure O.2: Features and critical dimensions of bulldozer drawn tines.



Heave = freeboard required below tool bar



Calculation of effective depth of tine of 300mm width & 900mm in length below tool bar:

- i) potential maximum depth of decompaction is 1500mm with tine of 300mm width and 900mm with tine of 900mm length
- ii) potential effective operating depth for first soil layer is $900 - 200$ (freeboard) = 700mm
- iii) potential effective operating depth subsequent soil layer is $900 - (200 + 300$ [eg depth of recompacted lower material]) = 400mm

Figure O.3: Effective decompaction depth by tines.

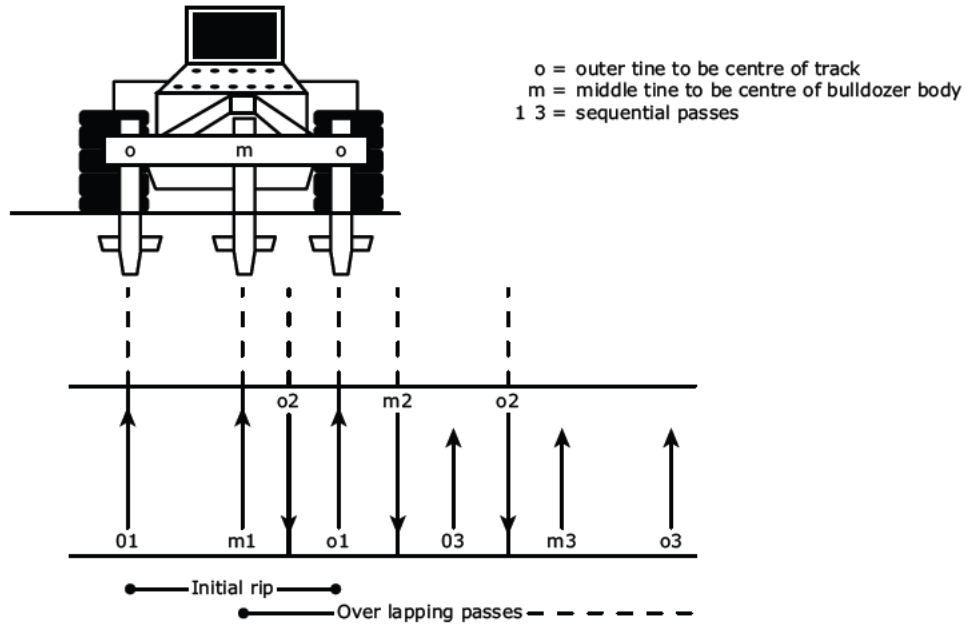

Figure O.4: Decompaction by overlapping passes of bulldozer drawn tines.

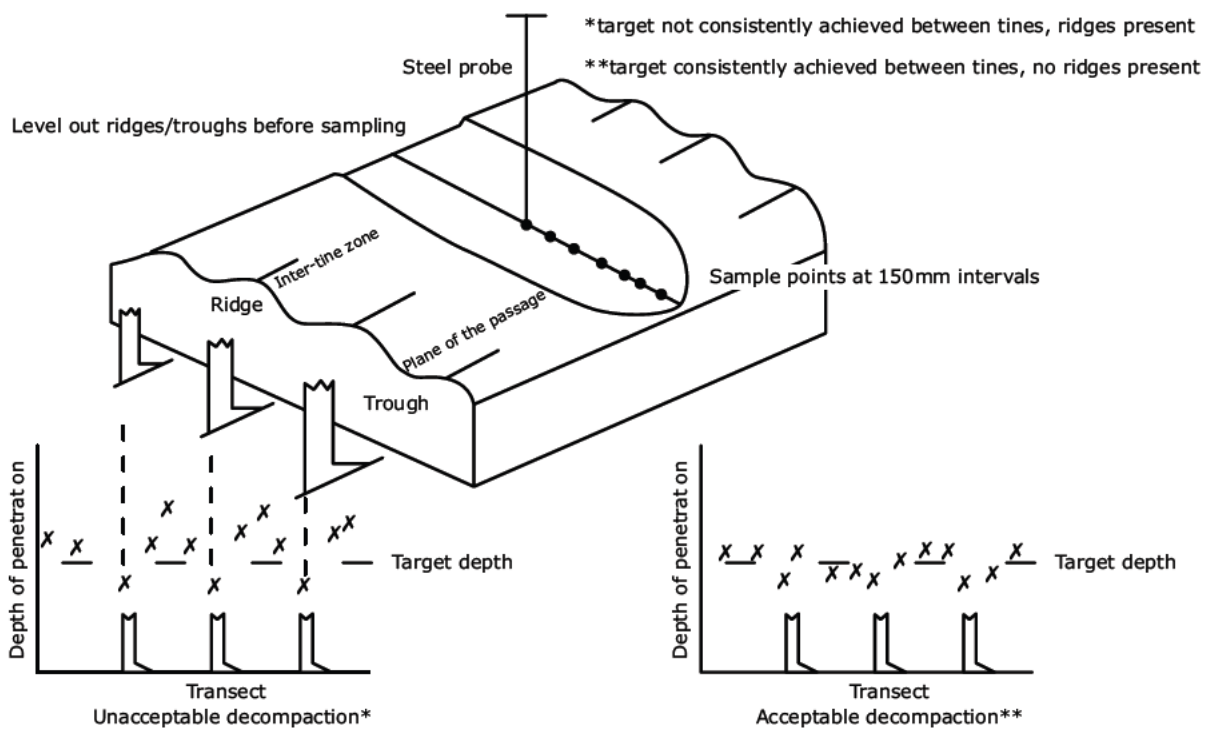

Figure O.5: Assessment of decompaction achieved.



Appendix C

Agricultural Good Practice Guidance for Solar Farms (2013)

Agricultural Good Practice Guidance for Solar Farms



EUROPEAN UNION
Investing in Your Future
European Regional
Development Fund 2007-2013

BRE
NATIONAL
SOLAR
CENTRE

Principal Author and Editor Dr Jonathan Scurlock, National Farmers Union

This document should be cited as: BRE (2014) Agricultural Good Practice Guidance for Solar Farms. Ed J Scurlock

BRE National Solar Centre would like to sincerely thank colleagues from the following organisations who have made significant contributions to the development of this guidance:



With thanks to:

Marcus Dixon and Neil Macdonald of British Solar Renewables; Liza Gray of Lightsource; Julie Rankin and Amy Thorley of Lark Energy; Kate Covill of Orta Solar; Ben Cosh of TGC Renewables; Ben Thompson of Foresight Group; Simon Stonehouse of Natural England; Leonie Greene of the Solar Trade Association; and Tom Fullick, Gary Ford and Richard Wordsworth of the NFU.

With thanks to NSC Founding Partners:



Context

This document describes experience and principles of good practice to date for the management of small livestock in solar farms established on agricultural land, derelict/marginal land and previously-developed land.

Proposed for publication as an appendix to existing best practice guidelines by the BRE National Solar Centre¹, it should be read in conjunction with BRE (2014) Biodiversity Guidance for Solar Developments (eds. G.E. Parker and L. Greene).

The guidance presented here has been developed with, and endorsed by, a number of leading UK solar farm developers and organisations concerned with agriculture and land management.

Introduction

Field-scale arrays of ground-mounted PV modules, or “solar farms”, are a relatively recent development, seen in Britain only since 2011, although they have been deployed in Germany and other European countries since around 2005. In accordance with the “10 Commitments” of good practice established by the Solar Trade Association², the majority of solar farm developers actively encourage multi-purpose land use, through continued agricultural activity or agri-environmental measures that support biodiversity, yielding both economic and ecological benefits.

It is commonly proposed in planning applications for solar farms that the land between and underneath the rows of PV modules should be available for grazing of small livestock. Larger farm animals such as horses and cattle are considered unsuitable since they have the weight and strength to dislodge standard mounting systems, while pigs or goats may cause damage to cabling, but sheep and free-ranging poultry have already been successfully employed to manage grassland in solar farms while demonstrating dual-purpose land use.

Opportunities for cutting hay or silage, or strip cropping of high-value vegetables or non-food crops such as lavender, are thought to be fairly limited and would need careful layout with regard to the proposed size of machinery and its required turning space. However, other productive options such as bee-keeping have already been demonstrated. In some cases, solar farms may actually enhance the agricultural value of land, where marginal or previously-developed land (e.g. an old airfield site) has been brought back into more productive grazing management. It is desirable that the terms of a solar farm agreement should include a grazing plan that ensures the continuation of access to the land by the farmer, ideally in a form that that enables the claiming of Basic Payment Scheme agricultural support (see page 2).



¹ BRE (2013) Planning guidance for the development of large scale ground mounted solar PV systems. www.bre.co.uk/nsc

² STA “Solar Farms: 10 Commitments” <http://www.solar-trade.org.uk/solarFarms.cfm>

Conservation grazing for biodiversity

As suggested in the Biodiversity Guidance described above, low intensity grazing can provide a cost-effective way of managing grassland in solar farms while increasing its conservation value, as long as some structural diversity is maintained. A qualified ecologist could assist with the development of a conservation grazing regime that is suited to the site's characteristics and management objectives, for incorporation into the biodiversity management plan.

Avoiding grazing in either the spring or summer will favour early or late flowering species, respectively, allowing the development of nectar and seeds while benefiting invertebrates, ground nesting birds and small mammals. Hardy livestock breeds are better suited to such autumn and winter grazing, when the forage is less nutritious and the principal aim is to prevent vegetation from overshadowing the leading (lower) edges of the PV modules (typically about 800-900mm high). Other habitat enhancements may be confined to non-grazed field margins (if provision is made for electric or temporary fencing) as well as hedgerows and selected field corners.

Agricultural grazing for maximum production

The developer, landowner and/or agricultural tenant/licensee may choose to graze livestock at higher stocking densities throughout the year over much of the solar farm, especially where the previous land use suggested higher yields or pasture quality. Between 4 and 8 sheep/hectare may be achievable (or 2-3 sheep/ha on newly-established pasture), similar to stocking rates on conventional grassland, i.e. between about March and November in the southwest and May to October in North-East England.

The most common practice is likely to be the use of solar farms as part of a grazing plan for fattening/finishing of young hill-bred 'store' lambs for sale to market. Store lambs are those newly-weaned animals that have not yet put on enough weight for slaughter, often sold by hill farmers in the Autumn for finishing in the lowlands. Some hardier breeds of sheep may be able to produce and rear lambs successfully under the shelter of solar farms, but there is little experience of this yet. Pasture management interventions such as 'topping' (mowing) may be required occasionally or in certain areas, in order to avoid grass getting into unsuitable condition for the sheep (e.g. too long, or starting to set seed).

Smaller solar parks can provide a light/shade environment for free-ranging poultry (this is now recognised by the RSPCA Freedom Foods certification scheme) – experience to date suggests there is little risk of roosting birds fouling the modules. Broiler (meat) chickens, laying hens and geese will all keep the grass down, and flocks may need to be rotated to allow recovery of vegetation. Stocking density of up to 2000 birds per hectare is allowed, so a 5 megawatt solar farm on 12 hectares would provide ranging for 24,000 birds.

Solar farm design and layout

In most solar farms, the PV modules are mounted on metal frames anchored by driven or screw piles, causing minimal ground disturbance and occupying less than 1% of the land area. The rest of the infrastructure typically disturbs less than 5% of the ground, and some 25-40% of the ground surface is over-shaded by the modules or panel. Therefore 95% of a field utilised for solar farm development is still accessible for vegetation growth, and can support agricultural activity as well as wildlife, for a lifespan of typically 25 years.

As described above, the layout of rows of modules and the width of field margins should anticipate future maintenance costs, taking into account the size, reach and turning circle of machinery and equipment that might be used for 'topping' (mowing), collecting forage grass, spot-weeding (e.g. of 'injurious' weeds like ragwort and dock) and re-seeding. Again, in anticipation of reverting the field to its original use after 25 years, many agri-environmental measures may be better located around field margins and/or where specifically recommended by local ecologists. All European farmers are obliged to maintain land in "good agricultural and environmental condition" under the Common Agricultural Policy rules of 'cross compliance', so it is important to demonstrate sound stewardship of the land for the lifetime of a solar farm project, from initial design to eventual remediation.

The depth of buried cables, armouring of rising cables, and securing of loose wires on the backs of modules all need to be taken into consideration where agricultural machinery and livestock will be present. Cables need to be buried according to national regulations and local DNO requirements, deep enough to avoid the risk of being disturbed by farming practice – for example, disc harrowing and re-seeding may till the soil to a depth of typically 100-150 mm, or a maximum of 200 mm. British Standard BS 7671 ("Wiring Regulations") describes the principles of appropriate depth for buried cables, cable conduits and cable trench marking. Note also that stony land may present a risk of stone-throw where inappropriate grass management machinery is used (e.g. unguarded cylinder mowers).

Eligibility for CAP support and greening measures

From 2015, under the Common Agricultural Policy, farmers will be applying for the new Basic Payment Scheme (BPS) of area-based farm support funding. It has been proposed that the presence of sheep grazing could be accepted as proof that the land is available for agriculture, and therefore eligible to receive BPS, but final details are still awaited from Defra at the time of writing. Farmers must have the land "at their disposal" in order to claim BPS, and solar farm agreements should be carefully drafted in order to demonstrate this (BPS cannot be claimed if the land is actually rented out). Ineligible land taken up by mountings and hard standing should be deducted from BPS claims, and in the year of construction larger areas may be temporarily ineligible if they are not available for agriculture.

Defra has not yet provided full details on BPS 'greening' measures, but some types of Ecological Focus Areas may be possibly located within solar farms, probably around the margins, including grazed buffer strips and ungrazed fallow land, both sown with wildflowers. Note that where the agreed biodiversity management plan excludes all forms of grazing, the land will become ineligible for BPS, and this may have further implications for the landowner, such as for inheritance tax.

Long-term management, permanent grassland and SSSI designation

Since solar farms are likely to be in place typically for 25 years, the land could pass on to a succeeding generation of farmers or new owners, and the vegetation and habitat within the fenced area is expected to gradually change with time. According to Natural England, there is little additional risk that the flora and fauna would assume such quality and interest that the solar farm might be designated a SSSI (Site of Special Scientific Interest) compared with a similarly-managed open field. However, there could be a possible conflict with planning conditions to return the land to its original use at the end of the project, e.g. if this is specified as 'cropland' rather than more generically as 'for agricultural purposes'. If the pasture within a solar farm were considered to have become a permanent grassland, it may be subject to regulations requiring an Environmental Impact Assessment to restore the original land use, although restoration clauses in the original planning consent may take precedence here. It is proposed that temporary (arable) grassland should be established on the majority of the land area that lies between the rows of modules. This would be managed in 'improved' condition by periodic harrowing and re-seeding (e.g. every 5 years), typically using a combination disc harrow and seed drill.

Other measures to maintain the productivity of grassland, without the need for mechanised cultivations or total reseedling, could include: maintaining optimum soil fertility and pH to encourage productive grass species; seasonally variable stocking rates to prevent over/under-grazing with the aim of preventing grass from seeding and becoming unpalatable. Non-tillage techniques to optimise grass sward content might include the use of a sward/grass harrow and air-seeder to revive tired pastures. When applying soil conditioners (e.g. lime), fertilisers or other products, consideration should be taken to prevent damage to or soiling of the solar modules.

Good practice in construction and neighbourliness

Consideration should also be given to best practice during construction and installation, and ensuring that the future agricultural management of the land (such as a change from arable cropping to lamb production) fits into the local rural economy. Site access should follow strictly the proposed traffic management plan, and careful attention to flood and mud management in accordance with the Flood Risk Assessment (e.g. controlling run-off by disrupting drainage along wheelings), will also ensure that the landowner remains on good terms with his/her neighbours.

Time of year should be taken into account for agricultural and biodiversity operations such as prior seeding of pasture grasses and wildflowers. Contractors should consider avoiding soil compaction and damage to land drains, e.g. by using low ground pressure tyres or tracked vehicles. Likewise, when excavating cable trenches, storing and replacing topsoil and subsoil separately and in the right order is important to avoid long-term unsightly impacts on soil and vegetation structure. Good practice at this stage will yield longer-term benefits in terms of productivity and optimal grazing conditions.

Evidence base and suggested research needs

A number of preliminary studies on the quantity and quality of forage available in solar farms have suggested that overall production is very little different from open grassland under similar conditions. A more comprehensive and independent evidence base could be established through a programme of directed research, e.g. by consultants (such as ADAS) or interested university groups (e.g. Exeter University departments of geography and biosciences), perhaps in association with seed suppliers and other stakeholders. Productivity of grasses could be compared between partial shade beneath the solar modules and unshaded areas between the rows. Alternatively daily live weight gain could be compared between two groups of fattening lambs (both under the same husbandry regime) on similar blocks of land, with and without solar modules present.



Case Steiger Quadtrac used to deliver inverters and other heavy equipment to site under soft ground conditions (photo courtesy of British Solar Renewables)



Cable trenching, showing topsoil stripped and set to one side, with subsoil placed on the other side ready for reinstatement (photo courtesy of British Solar Renewables)

Agricultural case studies

Benbole Farm, Wadebridge, Cornwall

One of the first solar farms developed in Britain in 2011, this 1.74 megawatt installation on a four-hectare site is well screened by high hedges and grazed by a flock of more than 20 geese. A community scheme implemented by the solar farm developers enabled local residents to benefit from free domestic solar panels and other green energy projects.



Higher Hill, Butleigh, Somerset

Angus Macdonald, a third-generation farmer, installed a five megawatt solar farm on his own land. Located near Glastonbury, the site has been grazed by sheep since its inception in 2011.



Eastacombe Farm, Holsworthy, Devon

This farm has been in the Petherick family for four generations, but they were struggling to survive with a small dairy herd. In 2011/12, a solar developer helped them convert eight hectares of the lower-grade part of their land into a 3.6 megawatt solar farm with sheep grazing, which has diversified the business, guaranteeing its future for the next generation of farmers.



Newlands Farm, Axminster, Devon

Devon sheep farmer Gilbert Churchill chose to supplement his agricultural enterprise by leasing 13 hectares of grazing land for a 4.2 megawatt solar PV development, which was completed in early 2013. According to Mr Churchill, the additional income stream is "a lifeline" that "will safeguard the farm's survival for the future".



Trevemper Farm, Newquay, Cornwall

In 2011, the Trewithen Estate worked with a solar developer to build a 1.7 megawatt solar farm on 6 hectares of this south-facing block of land, which had good proximity to a grid connection. During the 25-year lease, the resident tenant farmer is still able to graze the land with sheep at his normal stocking density, and is also paid an annual fee to manage the pasture.



Yeewood Solar Farm, North Somerset

Completed in 2012, this 1.3 megawatt installation on 4 hectares of land surrounds a poultry farm of 24,000 laying hens, which are free to roam the land between and underneath the rows of solar modules, as well as other fields. The Ford family, farm owners, also grow the energy crop miscanthus to heat their eco-friendly public swimming pool and office units.



Wyld Meadow Farm, Bridport, Dorset

Farmers Clive and Jo Sage continue to graze their own-brand Poll Dorset sheep on this 4.8 megawatt solar farm, established on 11 hectares in 2012. The solar farm was designed to have very low visual impact locally, with an agreement to ensure livestock grazing throughout the project's lifetime.



Wymeswold Solar Farm, Leicestershire

The author pictured in July 2014 at Britain's largest connected solar farm. At 33 megawatts, this development provides enough energy to power 8,500 homes. Built on a disused airfield in 2013, this extensive installation over 61 hectares (150 acres) received no objections during planning and is grazed by the landowner's sheep – just visible in the background.



BRE National Solar Centre

Foundation Building, Eden Project,
Bodelva, St Blazey
PL24 2SG

T +44 (0)1726 871830
E nsc@bre.co.uk
www.bre.co.uk/nsc
Twitter @natsolarcentre

BRE Trust

The BRE Trust uses profits made by BRE Group to fund new research and education programmes, that will help it meet its goal of 'building a better world together'.

The BRE Trust is a registered charity in England & Wales:
No. 1092193, and Scotland: No. SC039320.

Appendix D

**Defra Construction Code of Practice for the Sustainable Use of soils on Construction Sites
(extracts only)**

www.defra.gov.uk

Construction Code of Practice for the Sustainable Use of Soils on Construction Sites



BIS | Department for Business
Innovation & Skills



Material change for
a better environment

defra 
Department for Environment
Food and Rural Affairs

Soil management during construction

5.4 Soil stockpiling

Why?

1. Soil often has to be stripped or excavated during the construction process. In order to enable its reuse on site at a later stage, soil needs to be stored in temporary stockpiles to minimise the surface area occupied, and to prevent damage from the weather and other construction activities.



How?

2. The main aim when temporarily storing soil in stockpiles is to maintain soil quality and minimise damage to the soil's physical (structural) condition so that it can be easily reinstated once respread. In addition, stockpiling soil should not cause soil erosion, pollution to watercourses or increase flooding risk to the surrounding area.
3. When soil is stored for longer than a few weeks, the soil in the core of the stockpile becomes anaerobic and certain temporary chemical and biological changes take place. These changes are usually reversed when the soil is respread to normal depths. However, the time it takes for these changes to occur very much depends on the physical condition of the soil.
4. Handling soil to create stockpiles invariably damages the physical condition of the soil to a greater or lesser extent. If stockpiling is done incorrectly the physical condition of the soil can be damaged irreversibly, resulting in a loss of a valuable resource and potentially significant costs to the project. The Soil Resource Survey and Soil Resource Plan should set out any limitations that the soil may possess, with respect to handling, stripping and stockpiling.
5. The size and height of the stockpile will depend on several factors, including the amount of space available, the nature and composition of the soil, the prevailing weather conditions at the time of stripping and any planning conditions associated with the development. Stockpile heights of 3-4m are commonly used for topsoil that can be stripped and stockpiled in a dry state but heights may need to be greater where storage space is limited.
6. Soil moisture and soil consistency (plastic or non-plastic) are major factors when deciding on the size and height of the stockpile, and the method of formation. As a general rule, if the soil is dry (e.g. drier than the plastic limit) when it goes into the stockpile, the vast majority of it should remain dry during storage, and thereby enable dry soil to be excavated and respread at the end of the storage period. Soil in a dry and non-plastic state is less prone to compaction, tends to retain a proportion of its structure, will respread easily and break down into a suitable tilth for landscaping. Any anaerobic soil also usually becomes re-aerated in a matter of days.
7. Soil stockpiled wet or when plastic in consistency is easily compacted by the weight of soil above it and from the machinery handling it. In a compacted state, soil in the core of the stockpile remains wet and anaerobic for the duration of the storage period, is difficult to handle and respread and does not usually break down into a suitable tilth. A period of further drying and cultivation is then required before the soil becomes re-aerated and acceptable for landscaping.

Soil management during construction

Stockpiling methods

8. There are two principal methods for forming soil stockpiles, based on their soil moisture and consistency.
9. Method 1 should be applied to soil that is in a dry and non-plastic state. The aim is to create a large core of dry soil, and to restrict the amount of water that can get into the stockpile during the storage period. Dry soil that is stored in this manner can remain so for a period of years and it is reuseable within days of respreading.
10. Method 2 should be applied if the construction programme or prevailing weather conditions result in soil having to be stockpiled when wet and/or plastic in consistency. This method minimises the amount of compaction, while at the same time maximising the surface area of the stockpile to enable the soil to dry out further. It also allows the soil to be heaped up into a 'Method 1' type stockpile, once it has dried out.

Soil stockpiling

Soil should be stored in an area of the site where it can be left undisturbed and will not interfere with site operations. Ground to be used for storing the topsoil should be cleared of vegetation and any waste arising from the development (e.g. building rubble and fill materials). Topsoil should first be stripped from any land to be used for storing subsoil.

Method 1 – Dry non-plastic soils

The soil is loose-tipped in heaps from a dump truck (a), starting at the furthest point in the storage area and working back toward the access point. When the entire storage area has been filled with heaps, a tracked machine (excavator or dozer) levels them (b) and firms the surface in order for a second layer of heaps to be tipped. This sequence is repeated (c & d) until the stockpile reaches its planned height. To help shed rainwater and prevent ponding and infiltration a tracked machine compacts and re-grades the sides and top of the stockpile (e) to form a smooth gradient.

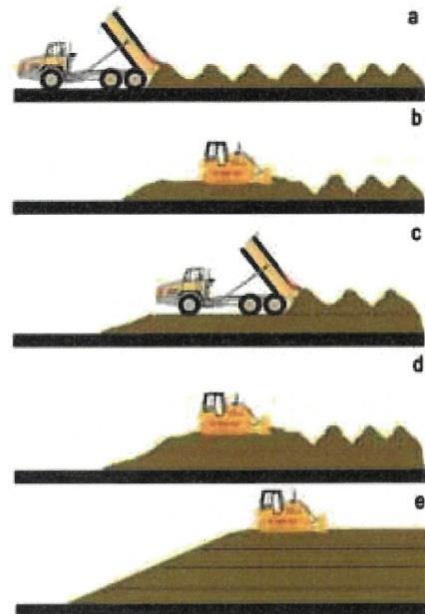

Soil management during construction

Method 2 – Wet plastic soils

The soil is tipped in a line of heaps to form a 'windrow', starting at the furthest point in the storage area and working back toward the access point (a). Any additional windrows are spaced sufficiently apart to allow tracked plant to gain access between them so that the soil can be heaped up to a maximum height of 2m (b). To avoid compaction, no machinery, even tracked plant, traverses the windrow.

Once the soil has dried out and is non-plastic in consistency (this usually requires several weeks of dry and windy or warm weather), the windrows are combined to form larger stockpiles, using a tracked excavator (d). The surface of the stockpile is then regraded and compacted (e) by a tracked machine (dozer or excavator) to reduce rainwater infiltration.

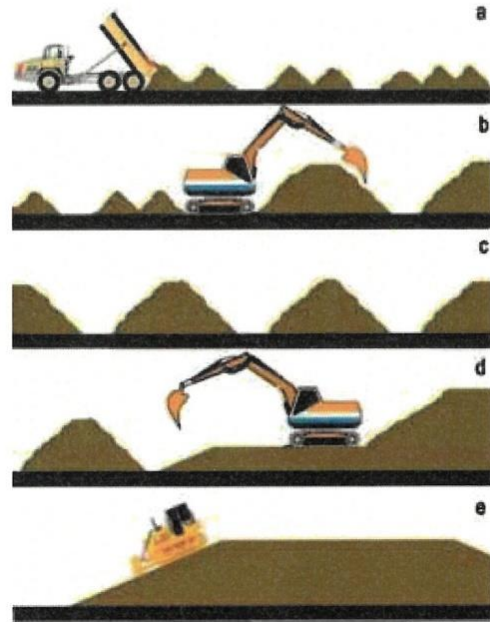

Stockpile location and stability

11. Stockpiles should not be positioned within the root or crown spread of trees, or adjacent to ditches, watercourses or existing or future excavations. Soil will have a natural angle of repose of up to 40° depending on texture and moisture content but, if stable stockpiles are to be formed, slope angles will normally need to be less than that. For stockpiles that are to be grass seeded and maintained, a maximum side slope of 1 in 2 (25°) is appropriate.

Stockpile protection and maintenance

12. Once the stockpile has been completed the area should be cordoned off with secure fencing to prevent any disturbance or contamination by other construction activities. If the soil is to be stockpiled for more than six months, the surface of the stockpiles should be seeded with a grass/clover mix to minimise soil erosion and to help reduce infestation by nuisance weeds that might spread seed onto adjacent land.
13. Management of weeds that do appear should be undertaken during the summer months, either by spraying to kill them or by mowing or strimming to prevent their seeds being shed.



Clearly defined stockpiling of different soil materials



Long term stockpile of stripped topsoil left with only weed vegetation

Appendix E
Outline Excavated materials Management Plan



MALLARDS PASS SOLAR FARM
OUTLINE EXCAVATED MATERIAL MANAGEMENT PLAN



Prepared By:

Arcus Consultancy Services

7th Floor
144 West George Street
Glasgow
G2 2HG

T +44 (0)141 221 9997 | **E** info@arcusconsulting.co.uk
w www.arcusconsulting.co.uk

Registered in England & Wales No. 5644976

TABLE OF CONTENTS

1	INTRODUCTION	1
1.1	Purpose of Document	1
1.2	The Order limits.....	1
1.3	The Proposed Development	2
2	DETAILED EMMPS	3
2.1	Use on Site of Origin.....	3
2.2	Detailed EMMPs.....	3
2.3	Verification Plan and Verification Report.....	4
2.4	Qualified Person Assessment	4
3	POTENTIAL MATERIAL GENERATION AND REUSE.....	6
3.1	Overview	6
3.2	Waste Arisings.....	6
3.2.1	Topsoil	6
3.2.2	Aggregate	7
3.2.3	Subsoil	7
3.2.4	Contaminated Soil	7
3.3	Movement of Materials.....	7
3.4	Record Keeping	7
4	WASTE MANAGEMENT	8
4.1	Waste Hierarchy	8
4.2	Waste Prevention	8
4.3	Waste Separation for Reuse and Recycle.....	8
4.4	Waste Storage, Disposal and Transportation.....	8

APPENDIX 1 – Example MMP Record

1 INTRODUCTION

1.1 Purpose of Document

This document provides an outline Excavated Materials Management Plan (oEMMP) to support the **outline Soil Management Plan (oSMP) [EN010127/APP/7.12]** for the Mallard Pass Solar Farm (hereby referred to as 'the Proposed Development'). Detailed EMMPs (based on this oEMMP) will be prepared alongside the SMPs, both of which will be produced for each phase (or more than one phase) of the Proposed Development pursuant to a Requirement of the Development Consent Order (DCO) prior to commencing construction.

The measures proposed within the oEMMP will be agreed prior to commencement of construction works with the relevant local planning authority. The EMMPs will be prepared following the appointment of a principal construction contractor, prior to the start of works and in accordance with this oEMMP.

This oEMMP has been prepared with the objective of compliance with the relevant legislation and mitigation measures identified through the Environmental Impact Assessment (EIA) process (see **Chapter 3: Description of Order limits** of the ES [EN010127/APP/6.1].)

This oEMMP provides the likely structure of the EMMPs and controls which might be included within the EMMPs to deliver the construction phase of the Proposed Development.

The appointed construction contractor will be responsible for working within the environmental controls documented in this oEMMP, pursuant to the DCO. The overall responsibility for implementation of the EMMPs will lie with the appointed contractor as a contractual responsibility to the Applicant, as the Applicant is ultimately responsible for compliance with the Requirements of the DCO.

1.2 The Order limits

The Order limits are described in **Chapter 3: Description of Order limits** of the ES.

They comprise the Solar PV Site, Mitigation and Enhancement Areas, Highway Works Site and the Grid Connection Corridor.

The Order limits' topography ranges between 16 – 67m above ordnance datum (AOD) with the lowest elevation running through the centre of the Order limits, partly along the route of the railway line. The highest elevation is present in the north-western extent of the Order limits.

The Order limits is currently accessible from a number of existing field accesses capable of accommodating large agricultural machinery.

In terms of the Strategic Road Network (SRN), the A1, which connects Grantham and Stamford, is located approximately 5.5km west of the centre of the Order limits, identified as being generally the centre of the village of Essendine. The A15, which connects Bourne and Peterborough, is located approximately 6.5km east of the centre of the Order limits, while the A1175 is located approximately 4.5km south of the centre of the Order limits, which provides a vehicular link between Stamford and Market Deeping and a link between Stamford and Oakham along the A606. The A6121, which connects Ryhall, Essendine and Carlby, separates the north-western extent of the Order limits from the remainder of the Order limits, routing on a general north-east to south-west alignment. The B1176 segments the north-westernmost extent of the Order limits and is routed on a general north-south direction.

The Macmillan Way recreational route follows the south-western boundary of the Order limits before crossing the south-central area and continuing along the northern boundary of the south-western extent of the Order limits.

The West Glen River runs through the Order limits on a general north-west – south-east alignment and separates the north-western extent from the remainder of the Order limits. A network of drains and streams, which follow field boundaries are present. The Order limits is predominantly located in Flood Zone 1, which is an area classed as having a low risk from fluvial and tidal flooding (less than 1 in 1,000 annual probability, as indicated by the Environment Agency Flood Map for Planning). The Order limits is predominantly located within an area of very low risk from surface water flooding. Areas of low to high surface water flood risk are located in the northern and western and central areas of the Order limits, associated with the West Glen River and its tributaries.

The Order limits predominantly comprises freely draining shallow lime-rich soils over chalk or limestone with an area of slowly permeable, seasonally wet, slightly acid but base-rich loamy and clayey soil type which has an impeded drainage characteristic in the eastern extent of the Order limits. Published British Geological Survey (BGS)¹ data information on superficial soils indicates the majority of the Project to be unrecorded. However, portions of the Order limits are underlain by Alluvium (clay, silt, sand, and gravel) and River Terrace Deposits (sand and gravel).

Published BGS mapping information on solid geology indicates the Project to be underlain by the following formations:

- a. Upper Lincolnshire Limestone Member – Limestone;
- b. Rutland Formation - Argillaceous Rocks With Subordinate Sandstone and Limestone;
- c. Blisworth Limestone Formation – Limestone;
- d. Blisworth Clay Formation – Mudstone;
- e. Kellaways Clay Member – Mudstone;
- f. Kellaways Sand Member - Sandstone and Siltstone, Interbedded;
- g. Cornbrash Formation – Limestone; and
- h. Oxford Clay Formation – Mudstone.

Published BGS Geosure mapping² indicates that no faulting exists on or within 5 km of the Order limits.

1.3 The Proposed Development

The Proposed Development is described in **Chapter 5: Project Description** of the ES.

¹ BGS (2019): <http://mapapps.bgs.ac.uk/geologyofbritain/home.html> (Accessed 06/07/2022)

² BGS (2019): <https://mapapps2.bgs.ac.uk/geoindex/home.html> (Accessed 04/08/2022)

2 DETAILED EMMPS

The Proposed Development should comply with good practice in accordance with CL:AIRE 'The Definition of Waste: Development Industry Code of Practice' (CoP). This document discusses the preparation of EMMPs which is synonymous for Material Management Plans set out in CL:AIRE. CL:AIRE provides three main scenarios for material excavation and management:

- a. Use on Site of Origin;
- b. Direct Transfer; and
- c. Cluster Projects

2.1 Use on Site of Origin

The definition of Use on Site of Origin within CL:AIRE includes a single site or area covered by a single planning permission or a number of parcels of land in close proximity to one another forming a larger development scheme. Excavated materials can be excavated and re-used in reinstatement at the Site of Origin on the provision that it is suitable for use. With regard to the Proposed Development, the Site of Origin is defined as the Order limits.

Where a Site of Origin approach is utilised and a cluster or direct transfer approach is not possible, surplus material should be removed offsite to an authorised waste management site.

Whenever it is envisaged that materials would be temporarily stored on site, and the use of those materials would occur more than one year from being stored, a time limit for such storage would be agreed with the Environment Agency (EA). The period of storage would take account of the extant consent or agreed programme of works. Given the presumed 2 year construction period for the Proposed Development, it is considered unlikely that this would be required.

2.2 Detailed EMMPs

The CL:AIRE CoP describes how the EMMPs will be prepared and is open to verification and sign-off by a Qualified Person (QP) and a declaration made to confirm that the materials are to be dealt with in accordance with the EMMPs. The QP must be chartered through a relevant professional body and be registered with CL:AIRE.

The principles for the use of site-won materials as 'non waste' require to comply with the CL:AIRE Protocol meaning the excavated materials must:

- a. Not be a risk to human health;
- b. Be suitable for their intended use without further processing (chemically and geotechnically);
- c. Be suitable for use following treatment under an appropriate Environmental Permit;
- d. Have a certainty of use (specified in planning, remediation strategies); and
- e. Be only the quantity that is absolutely necessary.

The EMMPs would be developed to include the above information, together with details of planning, site ownership, contractor details, consultations with statutory consultees, tracking systems and verification.

The Construction Code of Practice for the Sustainable Use of Soils on Construction Sites³. provides best practice guidance for the excavation, handling, storage and final placement of soils and which would be taken into account in the EMMPs and SMPs.

³ Construction Code of Practice for the Sustainable Use of Soils on Construction Sites. Defra 2009. Available at: <http://defraweb/environment/land/soil/index.htm>

Whilst this oEMMP provides a base standard for good practice, where avoidance or further minimisation of risks to the environment can be demonstrated through use of alternative methods or improvements to current practices, this will be reflected in the EMMPs

Each EMMP will require approval by the relevant local authorities, although it is intended that it will be maintained and updated by the contractor throughout the construction of the Proposed Development as a live document. It will be augmented by design specifications and construction documentation such as the Principal Contractor's construction phasing, and therefore at any given time will provide comprehensive information on the management of excavated materials appropriate to the stage of development.

2.3 Verification Plan and Verification Report

The Verification Plan included within the EMMPs would identify how the placement of materials would be recorded and the quantity of materials to be used. A Verification Report is produced and kept up to date throughout the construction period to provide an audit trail to show that materials and waste have gone to the correct destination(s). The Verification Report must also document any changes that may have been made to the EMMPs due to unforeseen alterations to the Proposed Development

2.4 Qualified Person Assessment

Each EMMP would be subject to review and declaration by a QP, who must be registered with CL:AIRE. The declaration serves as notification the QP is satisfied having reviewed the evidence relating to the proposed use of materials on site the CL:AIRE Code of Practice can be utilised appropriately.

All Declarations are added to the CL:AIRE Declaration management system for review by CL:AIRE before they issue a Declaration receipt to the QP. This carries a copy of the submitted information and is copied to the EA. The regulators add the information to their respective systems which informs local area teams.

Once the Declaration has been made, the organisation commissioning the QP must then follow the EMMPs and produce a Verification Report on the works, which would form part of the audit trail upon completion of the Proposed Development.

The QP would be required to review the various documents relating to the excavation and movement of materials. They must be suitably qualified and experienced to undertake the review and be confident in signing the Declaration.

The QP assessment process would include the following main lines of evidence:

- a. Has the source site of the excavated materials been adequately described and appropriate information provided that confirms that these materials will not cause harm to the environment or harm to human health in the proposed location of future use;
- b. Have all parties involved with the excavation and treatment of materials been identified;
- c. Have all the materials been adequately characterised and fall within the scope of the CoP;
- d. Has the EMMP been completed using the correct CL:AIRE template;
- e. Have all lines of evidence been followed and the appropriate regulators consulted and that they have no objection; and
- f. Is there enough evidence to demonstrate certainty of use of the excavated materials and of the correct quantity.

Subject to acceptance and sign off of the EMMP by the QP, there would be no requirement for the EA to have any input to the process other than for auditing purposes. This could

involve visiting the site and reviewing the EMMP documentation, operation and management at the site and at any site(s) receiving the material.

The EMMP should follow the layout of the example CL:AIRE template as included in **Appendix 1**.

3 POTENTIAL MATERIAL GENERATION AND REUSE

3.1 Overview

The construction of the Proposed Development will result in the excavation of materials, including topsoil and subsoil (clay, heavy clay loam, medium clay loam and sandy clay loam) and potentially even bedrock. During construction there will also be a requirement for the importation of aggregate materials.

Activities that will require the management of excavated materials are as follows:

- a. Temporary access areas and tracks;
- b. Construction compounds;
- c. Horizontal Directional Drilling;
- d. Watercourse crossings;
- e. Onsite Substation;
- f. Access tracks and Solar Stations;
- g. On-site trenching for cabling;

3.2 Waste Arisings

The construction of temporary access areas and compounds will primarily involve soil stripping which will mainly impact the topsoil. The construction of Solar Stations and trenching for the installation of cabling is likely to involve the excavation of subsoil as well as topsoil.

The preferred method for restoration of excavated or disturbed areas is to replicate, where practical, the principal habitat communities found within the area. Reinstatement will be undertaken by re-use of onsite vegetation and soil using turf/clodding methods. Vegetation monitoring will be carried out by the ECoCoW who will determine if re-seeding is required. Should re-seeding be required, species appropriate to the surrounding vegetation will be selected.

The sections below detail how different types of excavated materials will be stored and used in the reinstatement process.

3.2.1 Topsoil

Topsoil will be stored beside the construction area for use in re-instatement. Consideration will be given to the potential for entrapment of water in their placement.

For temporary works areas, such as temporary access tracks and construction compounds, soils should be stripped in layers when the soil is sufficiently dry to a depth of 10 – 15cm and stockpiled adjacent to the work area for use in reinstatement. In areas where permanent infrastructure is proposed, 30cm is considered an acceptable maximum depth for topsoil in most cases.

In areas of trenching, the vegetation layer and topsoil will be removed and segregated from the removed subsoil for use in reinstatement. If necessary, where depth allows, further segregation of the vegetation layer and topsoil will be undertaken to prevent burying of the upper vegetation layers in deeper soil on replacement.

The stripped turfs /topsoil will be stored adjacent to the compounds, the quantities of soil involved are limited and topsoil bunds of circa 2m. The soil will be used for future restoration in areas of fixed equipment, while surplus topsoil would be used to restore affected areas after construction or removed from the Order limits.

3.2.2 Aggregate

Aggregates will be stored either in construction compound storage areas, designated storage areas within the Order limits or local to working zones with 'on-time' delivery planned where required, but within the constraints of the CEMP and the CTMP. Aggregates will be used in construction of access tracks and preparation of compounds and substation or in the structural fill for foundations.

Aggregate will also be required in the construction of temporary infrastructure, including access tracks and construction compounds. Upon completion of construction, the aggregate is dug up and removed before the area is reinstated with the subsoils and topsoil previously excavated from the area.

3.2.3 Subsoil

Any subsoil which requires to be removed wherever possible and stored separately from other materials, and ideally adjacent to the removal areas for future reinstatement.

These storage areas will be managed at least annually to prevent the growth of woody vegetation, such as brambles or shrubs.

3.2.4 Contaminated Soil

Any materials deemed contaminated during excavation will not be suitable for reuse if they are contaminated – they will be regarded as waste materials. Section 4 details the waste management strategy for the Order limits.

3.3 Movement of Materials

Soils will only be moved within the Order limits when the conditions are suitable, bunds of excavated soils should be allowed time to dry out after the winter. Bunds will not be disturbed before the beginning of May and wherever possible, trafficking would be avoided between the beginning of December and mid-March for the medium clay loam areas, or mid-November and early April for the heavy clay and clay areas.

3.4 Record Keeping

The movement of materials within and between sites will be tracked with an audit trail. The system will include:

- a. Annotated plans indicating the excavation areas, stockpiles and proposed placement areas;
- b. Inspection and testing methods and certificates; and
- c. Records of movements, from and to, delivery tickets.

A Materials Management Plan Form provided by CL:AIRE is included in **Appendix 1** as an example of record keeping of the movement of materials during the advancement of the Proposed Development.

4 WASTE MANAGEMENT

4.1 Waste Hierarchy

The 'Waste Hierarchy' provides an outline approach of how waste management should be assessed within the oEMMP, see Plate 1. The Waste (England and Wales) Regulations 2011⁴ places a duty on all persons who produce, keep or manage waste to apply the 'Waste Hierarchy' in order to minimise waste production at every stage of the Proposed Development.

The 'Waste Hierarchy' promotes selection of the Best Practicable Environmental Option (BPEO) and preferred option for management of waste.

Plate 1: Waste Hierarchy⁵

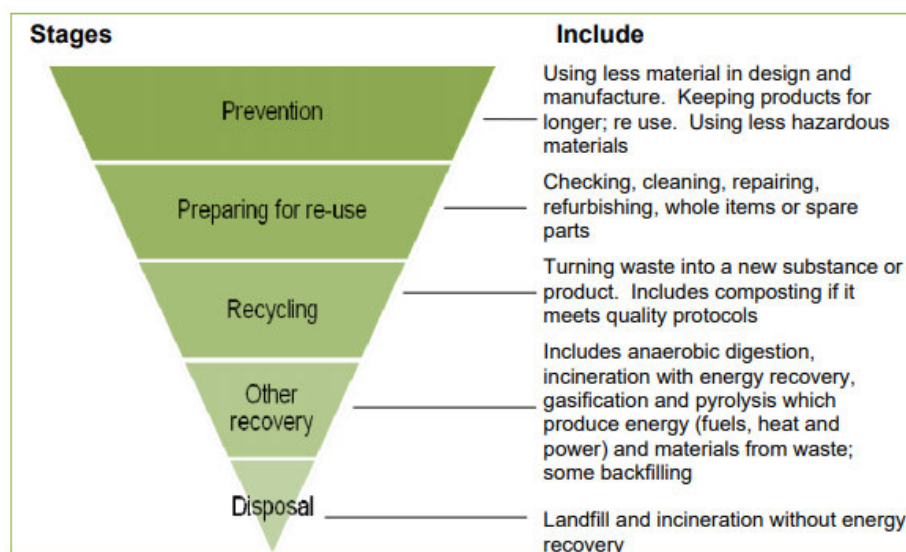

The core waste management principles of reduce, reuse, recycle, recover and disposal as defined in the 'Waste Hierarchy', are embedded within this oEMMP.

4.2 Waste Prevention

Minimisation of waste generation is achieved through careful design and creating a 'waste aware' culture on-site. All reasonable actions will be taken by the Contractor to avoid the production of and/or minimise the volume of waste produced as a result of the Proposed Development. This can be through reducing consumption, using resources efficiently, and designing for longevity.

4.3 Waste Separation for Reuse and Recycle

Where possible, the separation of waste will be carried out at the source in order to maximise opportunities for reuse and recycling. Segregation of waste will require training, monitoring and enforcement.

4.4 Waste Storage, Disposal and Transportation

All areas used for temporary storage of waste onsite will comply with Defra and EA guidelines and will be clearly signed. Waste storage facilities will be provided at source

⁴ Legislation (England and Wales) (2011): The Waste (England and Wales) Regulations 2011 [Online] Available at: <https://www.legislation.gov.uk/ukxi/2011/988/contents/made> (Accessed 30/06/2022)

⁵ Defra (2011) Guidance on applying the Waste Hierarchy [Online] Available at: https://assets.publishing.service.gov.uk/government/uploads/system/uploads/attachment_data/file/69403/pb13530-waste-hierarchy-guidance.pdf (Accessed 30/06/2022)

using the best environmental options available. Any hazardous or special waste will be stored in separate, secure containers and clearly identified as such.

Disposal activities will also be carried out in accordance with the EA, Pollution Prevention Guidelines (PPGs⁶) in order to ensure compliance with current waste legislation.

A review plan for the PPGs is currently underway, replacing them with a replacement guidance series, Guidance for Pollution Prevention (GPPs⁷). GPPs provide environmental regulatory guidance for Northern Ireland, Scotland and Wales and environmental good practice guidance for the whole UK.

As the Order limits are within England the PPGs still provide regulatory guidance for the Proposed Development, however the activities will also be carried out in accordance with GPPs to demonstrate environmental good practice.

Waste transportation will take place at regular intervals to avoid the accrual of waste. Where possible, delivery vehicles will aim to remove waste materials on return trips.

Only registered waste carriers will be authorised to transport waste and a Waste Transfer Note (WTN) will be completed for each load of waste, which must contain a record of their waste carrier registration number. The appropriate European Waste Catalogue (EWC) code will be established using updated Technical Guidance (WM3)⁸ and will be noted on the WTN, in addition to how it is contained. All sites receiving waste must have an appropriate permit, licence or registration exemption, the details of which should also be recorded.

If required, the EA will be advised in advance of any hazardous waste movements and Waste Consignment Notes (WCNs) will be purchased in advance for this type of waste transportation. These consignment notes will be held for at least three years.

⁶ Environment Agency (2014): Pollution prevention guidance (PPG) [Withdrawn] Available at: <https://webarchive.nationalarchives.gov.uk/20140328090931/http://www.environment-agency.gov.uk/business/topics/pollution/39083.aspx> (Achieved material accessed 30/06/2022)

⁷ NetRegs (2021): Guidance for Pollution Prevention (GPP) [Online]. Available at: <https://www.netregs.org.uk/environmental-topics/guidance-for-pollution-prevention-gpp-documents/guidance-for-pollution-prevention-gpps-full-list/> (Accessed 30/06/2022)

⁸ Environment Agency, Scottish Environment Protection Agency & Natural Resources Wales (2015) Waste Classification: Guidance on the classification and assessment of waste (1st Edition v1.1.GB) Technical Guidance WM3, EU Exit Update (Jan 2021) [Online] Available at: https://assets.publishing.service.gov.uk/government/uploads/system/uploads/attachment_data/file/948735/Waste_classification_technical_guidance_WM3.pdf (Accessed 30/06/2022)

APPENDIX 1 - EXAMPLE EMMP RECORD

Materials Management Plan (MMP) Form - October 2014

This form should be completed once the lines of evidence have been marshalled in relation to suitability for use, certainty of use and quantity required.

The answers to the questions posed within this form, together with the supporting information will constitute the MMP and must be provided to the Qualified Person.

A Qualified Person may comment on draft versions of this MMP, but will not complete the Declaration until all the relevant documents, demonstrating lines of evidence have been provided for each site.

The person / organisation who will pay the Declaration fee should confirm that they have read and understand the Terms and Conditions relating to the payment of the Declaration fee to CL:AIRE. These can be found on the CL:AIRE website.

The person / organisation agreeing to pay the Declaration Fee - Name, organisation and contact details inc. email address -	
--	--

I confirm I have read and understood the Terms & Conditions.

Each question must be answered. If the question is not applicable please state this and provide a brief explanation.

1. Specify the scenario to which this MMP relates, as described in the Definition of Waste: Development Industry Code of Practice (DoW CoP) (1, 2, 3 or 4):

- 1. Reuse on the Site of Origin
- 2. Direct Transfer of clean naturally occurring soil / mineral materials
- 3. Cluster Project
- 4. Combination of any of the above

In the case of a combination of reuse scenarios, please describe it below (e.g. (i) Reuse on Site of Origin and Direct Transfer of clean naturally occurring unpolluted soils, (ii) Reuse on the Site of Origin with Direct Transfer of clean naturally occurring soil to x number of development sites etc:

(NB: A Declaration is required for reuse on the Site of Origin and for any 2 site arrangement i.e. there is no facility for a combination Declaration)

2. Organisation and name of person preparing this MMP	(Full address and contact details)
---	------------------------------------

Document Control

Date issued	
Revision date	
Summary of revision 1	
Summary of revision 2	

Insert additional lines to the table above for any subsequent revisions.

Note - revisions to the MMP do not trigger an additional Declaration by a Qualified Person, unless an additional site is added to the project.

Revisions to the MMP must be recorded and summarised in the Document Control box above.

Site Details

3. Site / Project name(s)	
Reuse / receiving site name :	
Donor site name (if Direct Transfer)	

Landowners

4a. Name of Landowner(s) (full address and contact details) – where excavated materials are to be reused	
4b. Name of Landowner(s) (full address and contact details) – where excavated materials are arising from	

Summary and objectives

5a. Provide a brief description of the planned project and how excavated materials are to be reused.	
--	--

General Plans and Schematics

6. Attach a location plan for the site(s) and a plan of the site(s) which identifies where different materials are to be excavated from, stockpile locations (if applicable), where materials are to be treated (if applicable) and where materials are to be reused.	Plan Document Reference(s):
--	-----------------------------

7. Attach a schematic of proposed materials movement. Where there is only one source area and one placement area briefly describe it. For all other projects a schematic is required.	Description & Schematic Document Reference:
--	---

Parties Involved and Consultation – if more than one party please provide additional details for them and identify the location that they will be working e.g. where a site is zoned

8a. Main earthworks contractor(s) (full address and contact details) – Where excavated materials are to be reused	
8b. Main earthworks contractor(s) (full address and contact details) - Where excavated materials are arising from	

9. Treatment contractor(s) (full address and contact details) – for treatment on site of origin, or at a Hub site within a fixed STF / Cluster Project	
10. Where wastes and materials are to be transported between sites, provide details of the transport contractor(s) (full address, contact details and waste carriers registration details (if applicable))	
11. Provide Local Authority contact details (full address and named contacts) where excavated materials are to be reused	
12a. For the site where materials are to be reused and for Hub Site locations provide Environment Agency contact details (full address and named contacts):	
For all Cluster Projects:	EA references:
12b. Attach any relevant documentation	

<p>from the EA relating to the excavation and reuse of the materials to demonstrate no objection to the proposals (see 3.37 of DoW CoP)</p> <p>If the EA has not been consulted please explain why (see paragraph 3.39 of the DoW CoP).</p>	
---	--

Lines of Evidence

There is no one single factor that can be used to decide that a substance or object is waste, or when it is, at what point it ceases to be waste; as complete a picture as possible has to be created.

The following sections require completion to ensure the correct decision is made.

If a requested item is not relevant it is important to clearly state why this is so (e.g. no planning permission required because permitted development status exists).

Suitable for use criteria

13. Please describe or provide copies of the required specification(s) for the materials to be reused on each site.	Document Reference(s):
<p><i>Where contamination is suspected or known to be present</i></p> <p>14a. Please provide copies of or relevant extracts from the risk assessment(s) that has been used to determine the specification for use on the site. This must relate to the place where materials are to be used. This must be in terms of (i) human health (ii) controlled waters and (iii) any other relevant receptors. If a risk assessment is not relevant for a particular receptor given the site setting please explain why below:</p>	Document Reference(s):
14b. Please attach any relevant documentation from the LA relating to the excavation and reuse of the materials to demonstrate no objection (see 3.37 of the CoP)	LA Document references:
14c. Please attach any relevant	EA Document references:

documentation from the EA relating to the excavation and reuse of the materials to demonstrate no objection (see 3.37 and Table 2 of the CoP)	
14d. Please attach any relevant documentation from any other regulators (if relevant) relating to the excavation and reuse of the materials to demonstrate no objection (see 3.37 of the CoP)	Document Reference(s):

<i>Where contamination is not suspected</i>	Document Reference(s)
15a. Please attach copies or relevant extracts from the Desk Top Study that demonstrates that there is no suspicion of contamination.	
15b. Please attach copies of or relevant extracts from the site investigation/testing reports that adequately characterise the clean materials to be used (if appropriate).	Document Reference(s)
15c. Please attach copies of any other relevant information (if available) confirming that land contamination is not an issue.	Document Reference(s)

NB: It is your responsibility to assess the nature of the material to be used and that it fits within the limitations of the scenario under which it is to be used

Certainty of use

Various lines of evidence are required to demonstrate that the materials are certain to be used. This includes:

- The production of this MMP
- An appropriate planning permission (or conditions that link with the reuse of the said materials)
- An agreed Remediation Strategy(ies)
- An agreed Design Statement(s)
- Details of the contractual arrangements

Please identify in the following sections what lines of evidence relate to the site(s) **where the materials are to be used**.

<p>16a. Planning Permission(s) relating to the site where materials are to be reused</p> <p>Please provide a copy of the relevant planning permission</p>	<p>Document Reference:</p>
<p>16b. Explain how the reuse of the excavated materials fits within the planning</p>	

permission(s) for each site.	
16c. If planning permission is not required for any one site please explain why below e.g. permitted development, clean up of a chemical spill, surrender of an Environmental Permit, re-contouring within the existing permission.	
Where contamination is suspected or is known to be present 17. Please provide a copy of any Remediation Strategy(ies) that have been agreed with relevant regulators.	Document Reference(s):
Where contamination is not suspected 18. Please provide a copy of any Design Statement(s) that have been agreed (e.g. with the planning authority or in the case of permitted developments the client).	Document Reference(s):

Quantity of Use

<p>19. Please provide a breakdown of the excavated materials for each site and how much will be placed at each site or sub area of each site.</p> <p>Where this is not specific to a single readily identifiable source refer to an annotated plan, schematic or attach a tabulated summary.</p>	Document Reference(s):
20a. How has consolidation/compaction being considered in the above mass balance calculations?	
20b. How has loss due to treatment being considered in the above mass balance calculations (if applicable)?	
20c. How has the addition of treatment materials being considered in the above mass balance calculations (if applicable)?	
Note - An exact figure is not required but	

one that is reasonable in the circumstances and can be justified if challenged.	
---	--

Contingency arrangements

Explain what is to happen in the following situations and **identify the appropriate clauses** in the contract(s) (Such clauses must be provided to the Qualified Person, preferably as a summary document): or

21a. What is to happen to, and who is to pay for out of specification materials?	Reference:
21b. What is to happen to, and who is to pay for any excess materials?	Reference:
21c. What happens if the project programme slips in relation to excavated materials or materials under -going treatment?	Reference:
21d. Other identified risk scenarios for the project (relating to excavated materials)?	Reference:

The Tracking System

Where contamination is suspected or known to be present, state the procedures put in place to:

22a. For all sites please describe the tracking system to be employed to monitor materials movements.	
<i>Where contamination is suspected or known to be present, state the procedures put in place to:</i> 22b. Prevent contaminants not suitable for the treatment process being accepted	
<i>Where contamination is suspected or known to be present, state the procedures put in place to:</i> 22c. Prevent cross contamination of materials not in need of treatment, wastes awaiting treatment and treated materials	
<i>Where contamination is suspected or known to be present, state the procedures put in place to:</i> 22d. Demonstrate that materials that do not require treatment and successfully treated materials reach their specific destination	
<i>Where contamination is suspected or known to be present, state the procedures put in place to:</i>	

<p>22e. Ensure that waste for off-site disposal or treatment is properly characterised and goes to the correct facility</p>	
<p>23. Please attach a copy of the tracking forms / control sheets that are to be used to monitor materials movements.</p> <p>To include transfer of loads on site into stockpiles prior to treatment (if applicable), stockpiled after treatment (if applicable), stockpiled awaiting use (as appropriate) and final placement.</p>	<p>Document reference(s)</p>
<p><i>For Hub Sites within Cluster Projects & where materials need treatment before reuse</i></p> <p>24. Please attach a copy of the Environmental Permit covering the treatment process.</p> <p>Alternatively if the treatment is covered by a</p>	<p>Permit reference / EA letter reference:</p>

Mobile Plant Permit and associated Deployment Form, attach a copy of the EA agreement to the Deployment Form.	
---	--

Records

<p>25. Where, and in what form, are records to be kept?</p> <p>Note – records e.g. transfer notes, delivery tickets, Desk Top Study, Site Investigation, Risk Assessment(s), Verification Report(s) need to be kept for at least 2 years after the completion of the works and production of the Verification Report</p>	
--	--

Verification Plan

26. Provide or explain the Verification Plan which sets out how you will record the placement of materials and prove that excavated materials have been reused in the correct location and in the correct	Document Reference
---	--------------------

quantities within the development works (see 3.4 of the DoW CoP).	
--	--



Greenacres Barn, Stoke Common Lane, Purton Stoke, Swindon, Wiltshire SN5 4LL
Telephone: 01793 771333 • Email: info@kernon.co.uk • Website: www.kernon.co.uk



